

Machining Science jigs and fixtures

(INTRODUCTION AND CONCEPTS OF NC/ CNC MACHINE)

Numerical Control

Computer Numeric Control (CNC) is the automation of machine tools that are operated by precisely programmed commands encoded on a storage medium (computer command module, usually located on the device) as opposed to controlled manually by hand wheels or levers, or mechanically automated by cams alone. Most NC today is **computer (or computerized) numerical control (CNC)**, in which computers play an integral part of the control.

In modern CNC systems, end-to-end component design is highly automated using computer-aided design (CAD) and computer-aided manufacturing (CAM) programs. The programs produce a computer file that is interpreted to extract the commands needed to operate a particular machine by use of a post processor, and then loaded into the CNC machines for production. Since any particular component might require the use of a number of different tools – drills, saws, etc. – modern machines often combine multiple tools into a single "cell". In other installations, a number of different machines are used with an external controller and human or robotic operators that move the component from machine to machine. In either case, the series of steps needed to produce any part is highly automated and produces a part that closely matches the original CAD design.

Definition

Computer Numerical Control (CNC) is one in which the functions and motions of a machine tool are controlled by means of a prepared program containing coded alphanumeric data. CNC can control the motions of the work piece or tool, the input parameters such as feed, depth of cut, speed, and the functions such as turning spindle on/off, turning coolant on/off.

Applications

The applications of CNC include both for machine tool as well as non-machine tool areas. In the machine tool category, CNC is widely used for lathe, drill press, milling machine, grinding unit, laser, sheet-metal press working machine, tube bending machine etc. Highly automated machine tools such as turning centre and machining centre which change the cutting tools automatically under CNC control have been developed. In the non-machine tool category, CNC applications include welding machines (arc and resistance), coordinate measuring machine, electronic assembly, tape laying and filament winding machines for composites etc.

Advantages and Limitations

The benefits of CNC are (1) high accuracy in manufacturing, (2) short production time, (3) greater manufacturing flexibility, (4) simpler fixturing, (5) contour machining (2 to 5 -axis machining), (6) reduced human error. The drawbacks include high cost, maintenance, and the requirement of skilled part programmer.

ELEMENTS OF A CNC

A CNC system consists of three basic components (Figure 2) : Part Program 1 . Part program 2 . Machine Control Unit (MCU) 3 . Machine tool (lathe, drill press, milling machine etc) The part program is a detailed set of commands to be followed by the machine tool. Each command specifies a position in the Cartesian coordinate system (x,y,z) or motion (workpiece travel or cutting tool travel), machining parameters and on/off function. Part programmers should be well versed with machine tools, machining processes, effects of process variables, and limitations of CNC controls. The part program is written manually or by using computerassisted language such as APT (Automated Programming Tool).

Machine Control Unit

The machine control unit (MCU) is a microcomputer that stores the program and executes the commands into actions by the machine tool. The MCU consists of two main units: the data processing unit (DPU) and the control loops unit (CLU). The DPU software includes control system software, calculation algorithms, translation software that converts the part program into a usable format for the MCU, interpolation algorithm to achieve smooth motion of the cutter, editing of part program (in case of errors and changes). The DPU processes the data from the part program and provides it to the CLU which operates the drives attached to the machine leadscrews and receives feedback signals on the actual position and velocity of each one of the axes. A driver (dc motor) and a feedback device are attached to the leadscrew. The CLU consists of the circuits for position and velocity control loops, deceleration and backlash take up, function controls such as spindle on/off.

Machine Tool

The machine tool could be one of the following: lathe, milling machine, laser, plasma, Coordinate measuring machine etc. Figure 3 shows that a right-hand coordinate system is used to describe the motions of a machine tool . There are three linear axes (x,y,z), three rotational axes (i,j,k), and other axes such as tilt (9) are possible. For example, a 5-axis machine implies any combination of x,y,z, i,j,k,and 6.

PRINCIPLES OF CNC

Basic Length Unit (BLU)

Each BLU unit corresponds to the position resolution of the axis of motion. For example, 1 BLU = 0.0001" means that the axis will move 0.0001" for every one electrical pulse received by the motor. The BLU is also referred to as Bit (binary digit).

$$\text{Pulse} = \text{BLU} = \text{Bit}$$

Point-to-Point Systems

Point-to-point systems are those that move the tool or the workpiece from one point to another and then the tool performs the required task. Upon completion, the tool (or workpiece) moves to the next position and the cycle is repeated (Figure 4). The simplest example for this type of system is a drilling machine where the workpiece moves.

In this system, the feed rate and the path of the cutting tool (or workpiece) have no significance on the machining process. The accuracy of positioning depends on the system's resolution in terms of BLU (basic length unit) which is generally between 0.001" and 0.0001".

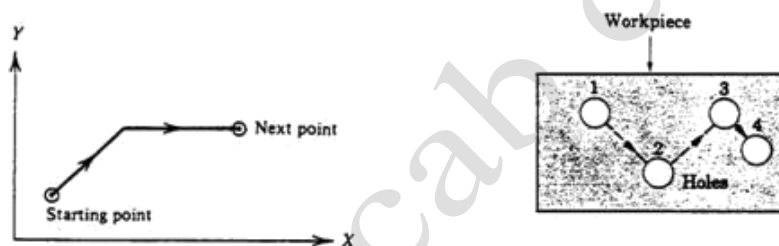

Figure 4. Cutter path between holes in a point-to-point system

Example 1

The XY table of a drilling machine has to be moved from the point (1,1) to the point (6,3). Each axis can move at a velocity of 0.5"/sec, and the BLU is 0.0001", find the travel time and resolution.

Travel time in X-axis is $(6-1)/0.5 = 10$ sec, in Y-axis is $(3-1)/0.5 = 4$ sec.

Travel time = 10 sec

Resolution = BLU = 0.0001

Continuous Path Systems (Straight cut and Contouring systems)

These systems provide continuous path such that the tool can perform while the axes are moving, enabling the system to generate angular surfaces, two-dimensional curves, or three-dimensional contours. Example is a milling machine where such tasks are accomplished (Figure 5). Each axis might move continuously at a different velocity. Velocity error is significant in affecting the positions of the cutter (Figure 5). It is much more important in circular contour cutting where one axis follows sine function while the other follows cosine function. Figure 6 illustrates point-to-point and continuous path for various machines.

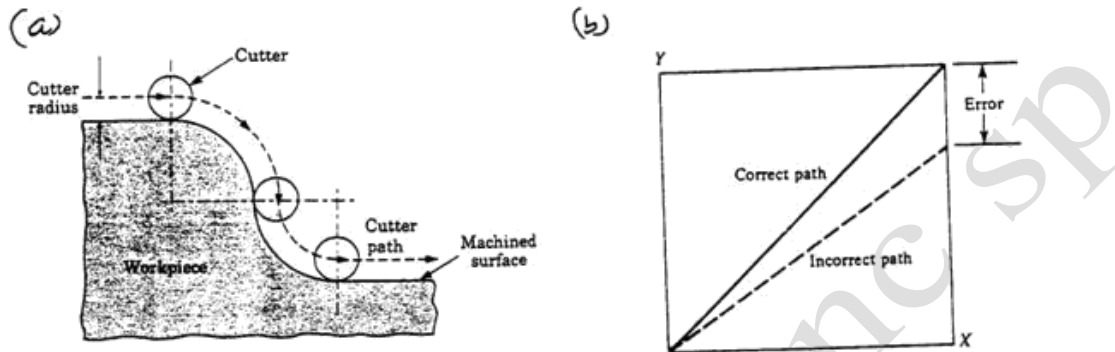

Figure 5. (a) Continuous path cutting and (b) Position error caused by the velocity error

Example 2

A CNC milling machine has to cut a slot located between the points (0,0) and (4,3) on the XY-plane where the dimensions are in inches. If the speed along the slot is to be 0.1 in/sec, find the cutting time and axial velocities.

$$\text{Distance traveled along the slot} = (16+9)^{1/2} = 5''$$

$$\text{Cutting time} = 5/0.1 = 50 \text{ sec}$$

$$V_x = xV/(x^2+y^2)^{1/2} = 4(0.1)/5 = 0.08 \text{ in/sec}$$

$$V_y = yV/(x^2+y^2)^{1/2} = 3(0.1)/5 = 0.06 \text{ in/sec}$$

If the velocity is Y-axis is off by 10%, what would be the new position ?

$$\text{New velocity in y is } 0.9 \times 0.06 = 0.054 \text{ in/sec}$$

$$\text{In 50 sec, the y- will move a distance } [50(0.054)] = 2.7 \text{ in.}$$

Incremental and Absolute systems

CNC systems are further divided into incremental and absolute systems (Figure 8). In incremental mode, the distance is measured from one point to the next. For example, if you want to drill five holes at different locations, the x-position commands are $x + 500$, $+ 200$, $+ 600$, $- 300$, -700 , -300 . An absolute system is one in which all the moving commands are referred from a reference point (zero point or origin). For the above case, the x-position commands are $x 500, 700, 1300, 1000, 300, 0$. (Figure 8). Both systems are incorporated in most CNC systems. For an inexperienced operator, it is wise to use incremental mode.

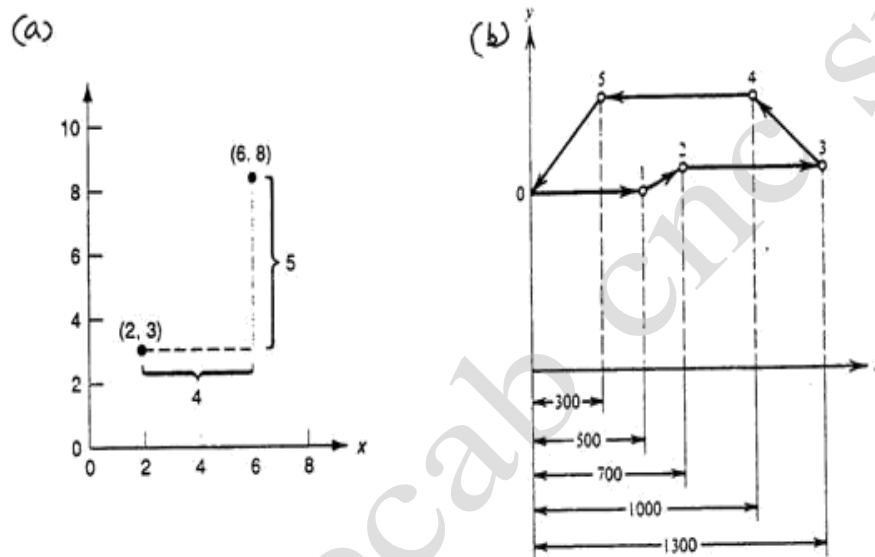

Figure 8. (a) Absolute versus incremental; In absolute positioning, the move is specified by $x = 6$, $y = 8$; in incremental, the move is specified by $x=4$, $y=5$ for the tool to be moved from (2,3) to (6,8)
(b) Drilling 5-holes at different locations

The absolute system has two significant advantages over the incremental system:

1. *Interruptions caused by, for example, tool breakage (or tool change, or checking the parts), would not affect the position at the interruption.*

If a tool is to be replaced at some stage, the operator manually moves the table, exchanges the tool, and has to return the table to the beginning of the segment in which the interruption has occurred. In the absolute mode, the tool is automatically returned to the position. In incremental mode, it is almost impossible to bring it precisely to that location unless you repeat the part program

2. *Easy change of dimensional data*

The incremental mode has two advantages over the absolute mode.

1. *Inspection of the program is easier because the sum of position commands for each axis must be zero. A nonzero sum indicates an error. Such an inspection is impossible with the absolute system.*
2. *Mirror image programming (for example, symmetrical geometry of the parts) is simple by changing the signs of the position commands.*

Open Loop Control Systems

The open-loop control means that there is no feedback and uses stepping motors for driving the leadscrew. A stepping motor is a device whose output shaft rotates through a fixed angle in response to an input pulse (Figure 9). The accuracy of the system depends on the motor's ability to step through the exact number. The frequency of the stepping motor depends on the load torque. The higher the load torque, lower would be the frequency. Excessive load torque may occur in motors due to the cutting forces in machine tools. Hence this system is more suitable for cases where the tool force does not exist (Example: laser cutting).

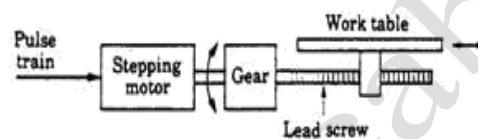

Figure 9. Open loop control system

The stepping motor is driven by a series of electrical pulses generated by the MCU. Each pulse causes the motor to rotate a fraction of one revolution. The fraction is expressed in terms of the step angle, α , given by

$$\alpha = 360/N, \text{ degrees where } N = \text{number of pulses required for one revolution}$$

If the motor receives "n" number of pulses then the total angle,

$$A = n (360/N), \text{ degrees}$$

In terms of the number of revolutions, it would be (n/N)

If there is a 1:1 gear ratio between the motor and the leadscrew, then the leadscrew has (n/N) revolutions. If the pitch of leadscrew is p (in/rev), then the distance traveled axially, say x ,

$$x = p(n/N)$$

can be used to achieve a specified x -increment in a point-to-point system.

The pulse frequency, f , in pulses/sec determines the travel speed of the tool or the workpiece.

$$60 f = N \text{ (RPM) where } N = \text{number of pulses per revolution,} \\ \text{RPM} = \text{RPM of the lead screw}$$

The travel speed, V , is then given by $V = p \text{ (RPM)}$ where p pitch in in/rev

Example 3

A stepping motor has $N = 150$, $p = 0.2$ "/rev; If $n = 2250$ pulses, what is the distance traveled in x-direction ? What should be the pulse frequency for a travel speed of 16 in./min ?

$$x = (0.2) (2250)/150 = 3"$$

$$16' = 0.2 \text{ (RPM), from which, RPM} = 80$$

$$f = (150) (80)/60 = 200 \text{ Hz}$$

Example 4

A stepping motor of 200 steps per revolution is mounted on the leadscrew of a drilling machine. If the pitch is 0.1 in/rev.,

- a. **What is the BLU ?**
- b. **If the motor receives a pulse frequency of 2000 Hz, what is the speed of the table ?**

a. $\text{BLU} = 0.1/200 = 0.0005"$

b. $\text{Table speed} = (p) \text{ (RPM)} = (0.1) (60) (2000)/200 = 60 \text{ in/min}$

Closed-loop Control Systems

Closed-loop NC systems are appropriate when there is a force resisting the movement of the tool/workpiece. Milling and turning are typical examples. In these systems (Figure 10) the DC servomotors and feedback devices are used to ensure that the desired position is achieved. The feedback sensor used is an optical encoder shown in Figure 11. The encoder consists of a light source, a photodetector, and a disk containing a series of slots. The encoder is connected to the leadscrew. As the screw turns, the slots cause the light to be seen by the

photodetector as a series of flashes which are converted into an equivalent series of electrical pulses which are then used to characterize the position and the speed. The equations remain essentially the same as open-loop except that the angle between the slots in the disk is the step angle, α .

Both the input to the control loop and the feedback signals are a sequence of pulses, each pulse representing a BLU unit. The two sequences are correlated by a comparator and gives a signal, by means of a digital-to-analog converter, (a signal representing the position error), to operate the drive motor (DC servomotor).

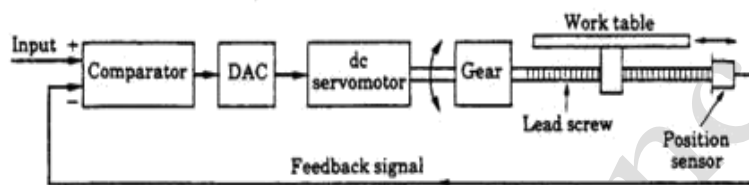

Figure 10. Closed loop control system

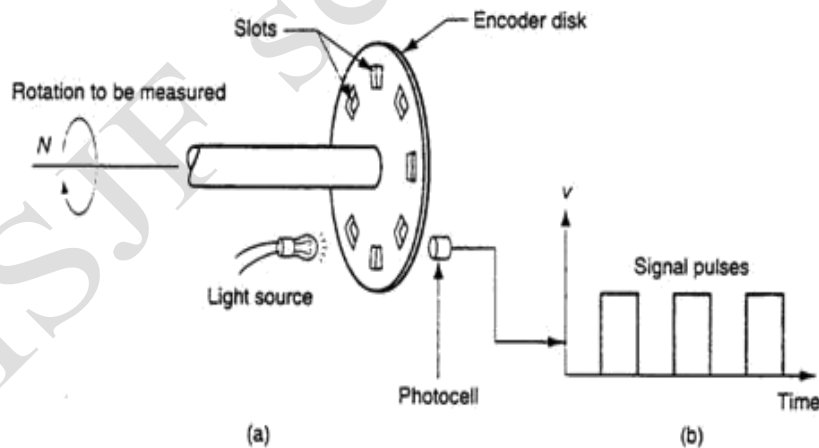

Figure 11. Optical Encoder (a) Device (b) Series of pulses emitted

Coordinate systems:

The machine tool is positioned by describing sets of coordinates. In the case of the VMC (Vertical Machining Centre) shown on the left, the coordinate will be described by 3 Axes.

A basic lathe operates by describing positions using 2 axes.

The coordinate system is laid out by identifying the Z axis first. The Z axis is always in line with the main rotating spindle. On the VMC this holds the cutting tool and is vertical; on the lathe this holds the work piece, it is horizontal and in line with the bed.

The X axis is used next and then the Y axis. The Axes for the VMC are shown in the image, the lathe uses just the Z and X axes.

The coordinate system used in most cases of CNC machining is a rectangular system, the technical name for this being the Cartesian coordinate system. When writing coordinates it is standard practise to write them in the order of X, Y, and Z.

When CNC programming the coordinate system must reference from a fixed point; this is called the origin or more commonly in manufacturing, the datum. The datum is the position where X, Y, and Z all equal zero. This is usually a point on the component and this position is usually decided by the manufacturing engineer or CNC programmer.

The coordinate system is almost always an absolute coordinate system. Absolute meaning all coordinates are measured from the datum. Other coordinate system are found in CNC manufacturing; it is not unusual to find Incremental (Relative) coordinates used on many machines and it is possible to use Polar coordinates on most machines.

Incremental coordinates do not refer back to the original datum, the position of the datum moves with the programmed coordinate. The machine moves towards a programmed position; when it gets to that position the position becomes X0Y0Z0 (the new datum). the next position is described from this new datum.

Polar coordinates can be used in Abs and Inc modes but the coordinate system is not rectangular; the Polar coordinate system is based on a rotating angle and length of radius. Basic programming - such as the programming used during the 16wk college course uses Cartesian coordinates using absolute positioning.

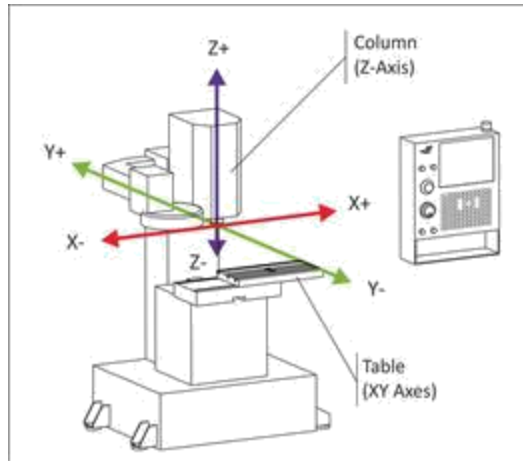

CARTESIAN COORDINATE

A **Cartesian coordinate system** is a coordinate system that specifies each point uniquely in a plane by a pair of numerical **coordinates**, which are the signed distances to the point from two fixed perpendicular directed lines, measured in the same unit of length. Each reference line is called a *coordinate axis* or just *axis* of the system, and the point where they meet is its *origin*, usually at ordered pair (0, 0). The coordinates can also be defined as the positions of the perpendicular projections of the point onto the two axes, expressed as signed distances from the origin.

One can use the same principle to specify the position of any point in three-dimensional space by three Cartesian coordinates, its signed distances to three mutually perpendicular planes (or, equivalently, by its perpendicular projection onto three mutually perpendicular lines). In general, n Cartesian coordinates (an element of real n -space) specify the point in an n -dimensional Euclidean space for any dimension n . These coordinates are equal, up to sign, to distances from the point to n mutually perpendicular hyper planes.

POLAR COORDINATE

In mathematics, the **polar coordinate system** is a two-dimensional coordinate system in which each point on a plane is determined by a distance from a reference point and an angle from a reference direction.

The reference point (analogous to the origin of a Cartesian system) is called the *pole*, and the ray from the pole in the reference direction is the *polar axis*. The distance from the pole is called the *radial coordinate* or *radius*, and the angle is called the *angular coordinate*, *polar angle*

AUTOMATIC TOOL CHANGER (ATC)

An **Automatic tool changer** or ATC is used in computerized numerical control (CNC) machine tools to improve the production and tool carrying capacity of the machine. ATC changes the tool very quickly, reducing the non-productive time. Generally, it

is used to improve the capacity of the machine to work with a numbers of tools. It is also used to change worn out or broken tools. It is one more step towards complete automation.

Simple CNC machines work with a single tool. Turrets can work with a large number of tools. But if even more tools are required, then ATC is provided. The tools are stored on a magazine. It allows the machine to work with a large number of tools without an operator. The main parts of an automatic tool changer are the base, the gripper arm, the tool holder, the support arm and tool magazines. Although the ATC increases the reliability, speed and accuracy, it creates more challenges compared to manual tool change, for example the tooling used must be easy to centre, be easy for the changer to grab and there should be a simple way to provide the tool's self-disengagement. Tools used in ATC are secured in toolholders specially designed for this purpose.

After receiving the tool change command, the tool to be changed will assume a fixed position known as the "tool change position". The ATC arm comes to this position and picks up the tool. The arm swivels between machine turret and magazine. It will have one gripper on each of the two sides. Each gripper can rotate 90°, to deliver tools to the front face of the turret. One will pick up the old tool from turret and the other will pick up the new tool from the magazine. It then rotates to 180° and places the tools into their due position.

The use of automatic changers increases the productive time and reduces the unproductive time to a large extent. It provides the storage of the tools which are returned automatically to the machine tool after carrying out the required operations, increases the flexibility of the machine tool. makes it easier to change heavy and large tools, and permits the automatic renewal of cutting edges.

DIRECT NUMERICAL CONTROL

Direct numerical control (DNC), also known as **distributed numerical control** (also **DNC**), is a common manufacturing term for networking CNC machine tools. On some CNC machine controllers, the available memory is too small to contain the machining program (for example machining complex surfaces), so in this case the program is stored in a separate computer and sent *directly* to the machine, one block at a time. If the computer is connected to a number of machines it can *distribute* programs to different machines as required. Usually, the manufacturer of the control provides suitable DNC software. However, if this provision is not possible, some software companies provide DNC applications that fulfill the purpose. DNC networking or DNC communication is always required when CAM programs are to run on some CNC machine control.

Wireless DNC is also used in place of hard-wired versions. Controls of this type are very widely used in industries with significant sheet metal fabrication, such as the automotive, appliance, and aerospace industries.

One of the issues involved in machine monitoring is whether or not it can be accomplished automatically in a practical way. In the 1980s monitoring was typically done by having a menu on the DNC terminal where the operator had to manually indicate what was being done by selecting from a menu, which has obvious drawbacks. There have been advances in passive monitoring systems where the machine condition can be determined by hardware attached in such a way as not to interfere with machine operations (and potentially void warranties). Many modern controls allow external applications to query their status using a special protocol. MT Connect is one prominent attempt to augment the existing world of proprietary systems with some open-source, industry-standard protocols and XML schemas and an ecosystem of massively multiplayer app development and mashups (analogous to that with smart phones) so that these long-sought higher levels of manufacturing business intelligence and workflow automation can be realized.

A challenge when interfacing into machine tools is that in some cases special protocols are used. Two well-known examples are Mazatrol and Heidenhain. Many DNC systems offer support for these protocols. Another protocol is DNC2 or LSV2 which is found on Fanuc controls. DNC2 allows advanced interchange of data with the control, such as tooling offsets, tool life information and machine status as well as automated transfer without operator intervention.

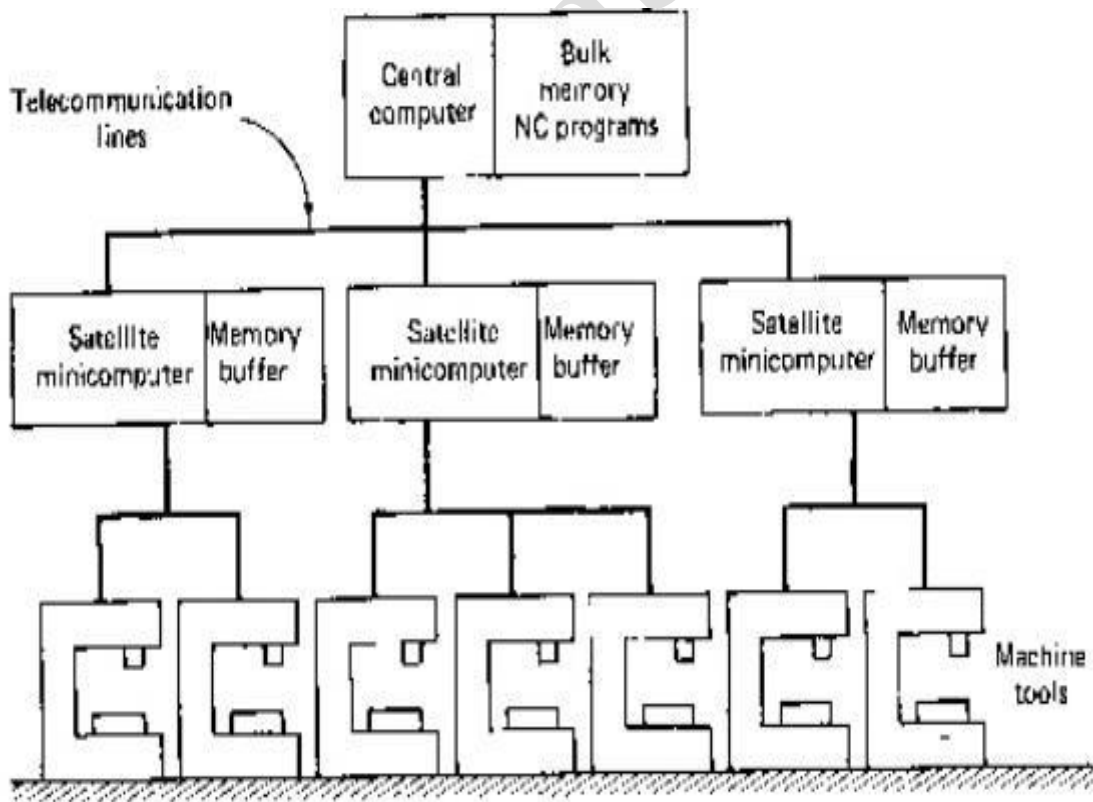

DIRECT NUMERICAL CONTROL

ECONOMICS OF CNC MACHINES

It is normal for a company to embark on a feasibility study prior to the purchase of any capital equipment such as a CNC machine tool. This study fulfils many functions, such as determining the capacity and power required together with its configuration - horizontal/vertical spindle for a machining centre, or flat, or slant bed for a turning centre. Many other features must also be detailed in the study, encompassing such factors, in the age of 5-axis machining, as the number of axes required and whether the machine tool should be loaded manually, by robot, or using pallets. An exhaustive list is drawn up of all the relevant points to be noted and others that at first glance seem rather esoteric, but will affect the ability of the company to manufacture its products. It has been shown time and again that many mistakes have been made in the past when companies rush into the purchase of new equipment without considering all of the problems, not only of the machine tool itself, but of the manning and training requirements together with its effect on the rest of the machine shops productive capability. Often the fact that an advanced, highly

productive machine is now present in the shop could affect the harmonious flow of production, causing bottlenecks later, when the purpose of purchasing the machine was to overcome those problems at an earlier production stage. Aerospace machine tools have even been purchased in the past without due regard for the components they must manufacture, or without correct assessment of future work.

This latter point is not often considered, as many companies are all too concerned with today's production problems rather than those of the future. Taking this theme a little further, in a volatile market a feasibility study should perceive not only the short and medium term productivity goals, but also the long term ones, as it is often the long term trends of productive capability which are the most important if a company is to amortise their costs. When highly sophisticated plant such as an FMS is required, it can be several years from its original conception before this is a reality on the shop floor, and a company's production demands may have changed considerably in the meantime. If, for any reason, the wrong machine has been purchased, or more likely, something has been overlooked during the feasibility study, then the "knock-on effect" of this poor judgement is that it will have cost the company dearly and, at the very least, any future study will be looked on by the upper management with disdain and scepticism.

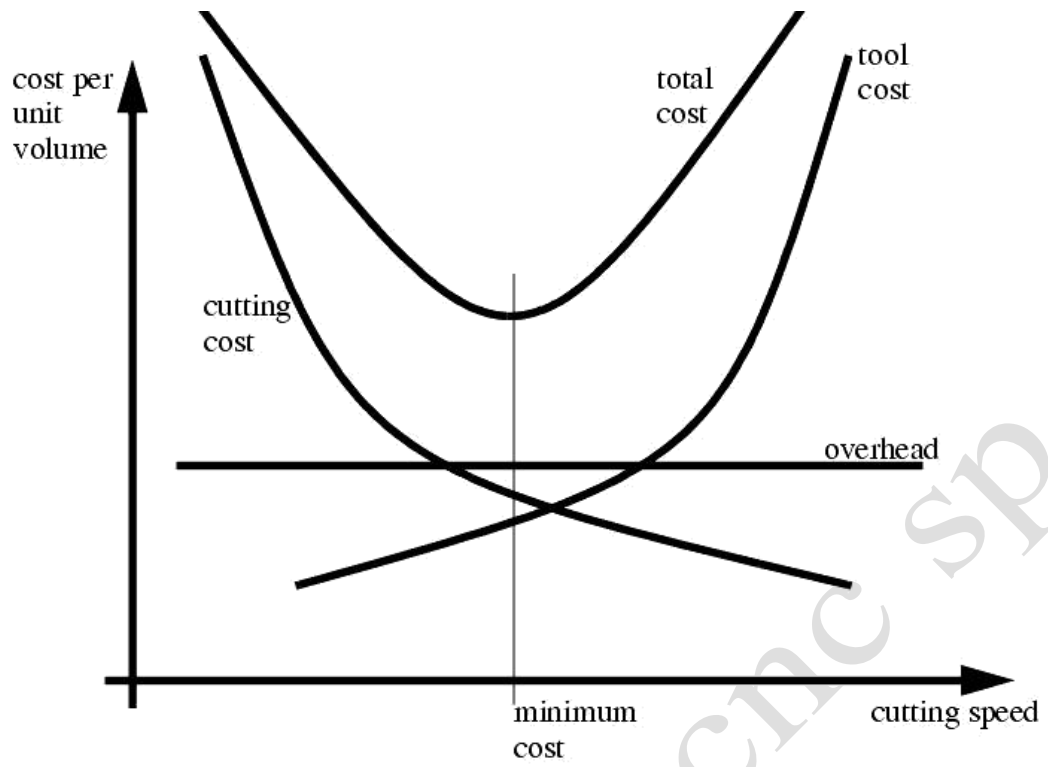

COST ANALYSIS

MSJF secad CNC SP