

MODULE – 1

LESSON CONTENTS:

Introduction to Machining Processes and Machine Tools: Subtractive manufacturing processes and classifications. Construction, specification operations of machine tools: – Lathe, Shaping, Milling, Drilling, Grinding Machine. Introduction to CNC machines: CNC Lathe, Milling, Drilling, Machine Center

Introduction to Machining Processes and Machine Tools:

Machining processes and machine tools play a crucial role in modern manufacturing industries. They are used to shape and form various materials into desired shapes and dimensions with high precision. This introduction will provide you with a basic understanding of machining processes, the types of machine tools used, and their applications.

Machining Processes:

Machining processes involve removing material from a workpiece to achieve the desired shape and size. Here are some commonly used machining processes:

Turning: Turning involves rotating the workpiece while a cutting tool removes material to create cylindrical shapes. It is commonly used to produce shafts, pins, and other rotational components.

Milling: Milling utilizes rotating cutting tools to remove material from the workpiece. It can create complex shapes and features, such as slots, holes, and contours. Milling machines are highly versatile and widely used in various industries.

Drilling: Drilling creates round holes in the workpiece using a rotating drill bit. It is used for creating holes of different sizes and depths.

Grinding: Grinding is a precision machining process that uses an abrasive wheel to remove material and achieve fine surface finishes. It is used for applications that require high accuracy and smooth surfaces, such as in the production of tools and dies.

Boring: Boring enlarges existing holes or creates internal cylindrical shapes using a single-point cutting tool. It is commonly used for precision machining of large components, such as engine cylinders.

Machine Tools:

Machine tools are power-driven machines used to carry out various machining processes. They provide the necessary motions and controls to shape and remove material from the workpiece. Here are some commonly used machine tools:

Lathe: A lathe is a machine tool used for turning operations. It holds the workpiece and rotates it while a cutting tool removes material. Lathes are used for producing cylindrical components, such as shafts and bushings.

Milling Machine: A milling machine uses rotating cutting tools to remove material from the workpiece. It can perform various operations, such as face milling, end milling, and drilling. Milling machines are versatile and can produce a wide range of shapes and features.

Drill Press: A drill press is a machine tool used for drilling operations. It holds the workpiece stationary while a rotating drill bit creates holes. Drill presses are available in various sizes and configurations to accommodate different drilling requirements.

Grinding Machine: Grinding machines use abrasive wheels to remove material and achieve precise surface finishes. They are used for grinding and sharpening tools, as well as for producing high-precision components.

Boring Machine: Boring machines are used to enlarge existing holes or create internal cylindrical shapes. They can be manual or CNC-controlled and are commonly used in industries such as automotive and aerospace.

Applications:

Machining processes and machine tools find applications in a wide range of industries, including automotive, aerospace, defense, electronics, and medical. They are used to manufacture components with high precision and accuracy, such as engine parts, gears, molds, and surgical instruments.

Conclusion:

Machining processes and machine tools are essential in modern manufacturing. They enable the production of complex components with high precision and repeatability. Understanding these processes and tools is crucial for anyone involved in manufacturing or engineering disciplines, as it forms the foundation of many industrial operations.

Subtractive manufacturing processes or (Machining processes)

Subtractive manufacturing processes, also known as machining processes, involve the removal of material from a solid workpiece to create the desired shape or form.

There are various classification methods for subtractive manufacturing processes, and here are some commonly used classifications:

Based on the tool type:

- a) **Conventional Machining:** These processes use traditional cutting tools, such as drills, lathes, milling machines, and grinders, to remove material through cutting, grinding, or drilling operations.
- b) **Abrasive Machining:** In this category, material is removed by using abrasive particles in the form of grinding wheels, honing stones, or abrasive belts to grind or polish the workpiece.
- c) **Non-Traditional Machining:** These processes use unconventional tools or energy sources, such as lasers, electron beams, or electrical discharges, to remove material.

Based on the nature of material removal:

- a. **Chip Removal Processes:** Material is removed in the form of chips, such as in milling, turning, drilling, or sawing operations.
- b. **Abrasive Processes:** Material is removed by the action of abrasive particles, as in grinding, honing, or lapping operations.
- c. **Electrochemical Processes:** Material is dissolved from the workpiece through electrochemical reactions, such as in electrochemical machining (ECM) or electrochemical grinding (ECG).
- d. **Thermal Processes:** Material is removed by localized melting or vaporization, as in laser cutting or plasma cutting.

Based on the control method:

- a. **Conventional Machining:** These processes are manually controlled, where operators guide the tools to remove material.
- b. **Computer Numerical Control (CNC) Machining:** These processes involve automated control using computer programs that guide the machine tools to perform precise operations.

Based on the type of motion:

- a. **Rotational Machining:** Material removal occurs through the rotation of the workpiece or the tool, such as in turning or drilling operations.

b. Linear Machining: Material removal occurs through linear motion of the tool or workpiece, such as in milling or shaping operations.

It's important to note that these classifications are not mutually exclusive, and some processes may fall into multiple categories depending on their characteristics and applications.

1.13 Introduction to basic metal cutting machine Tools – LATHE

A machine tool is a power-driven machine, designed to hold and move a sharp cutting tool against a rigidly held workpiece material or vice versa, so as to remove excess material from the workpiece in order to produce the desired shape, size and finish.

A few commonly used machine tools include, Lathe, Drilling machines, Milling machines, and Grinding machines.

There are a variety of machine tools designed for various applications, however in general, most machine tools perform the following functions:

- a) Hold the work material.
- b) Hold the cutting tool in position.
- c) Impart motion to the work material, or cutting tool, or both, in the desired direction.
- d) Regulate the cutting speed and also the feeding movement between the cutting tool and work material.

1.14 LATHE

- Lathe is the oldest of all machine tool and perhaps the most basic tool used in industries.
The lathe is a machine tool which holds the work piece between two rigid and strong supports called centers or in a chuck.
- The cutting tool is rigidly held and supported in a tool post which is fed against the revolving work.
- The normal cutting operations are performed with the cutting tool fed either parallel or at right angles to the axis of the work.
- The cutting tool may also be fed at an angle relative to the axis of work for machining tapers and angles.

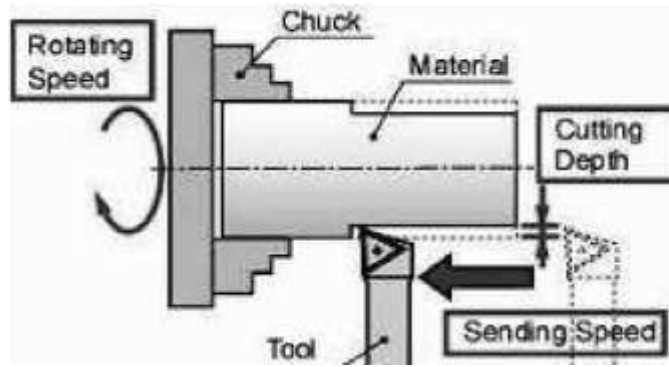

FIG. Principle of working of a lathe.

1.14.1 Construction of Centre Lathe:

The main parts of the lathe are the bed, headstock, quick changing gear box, carriage and tailstock.

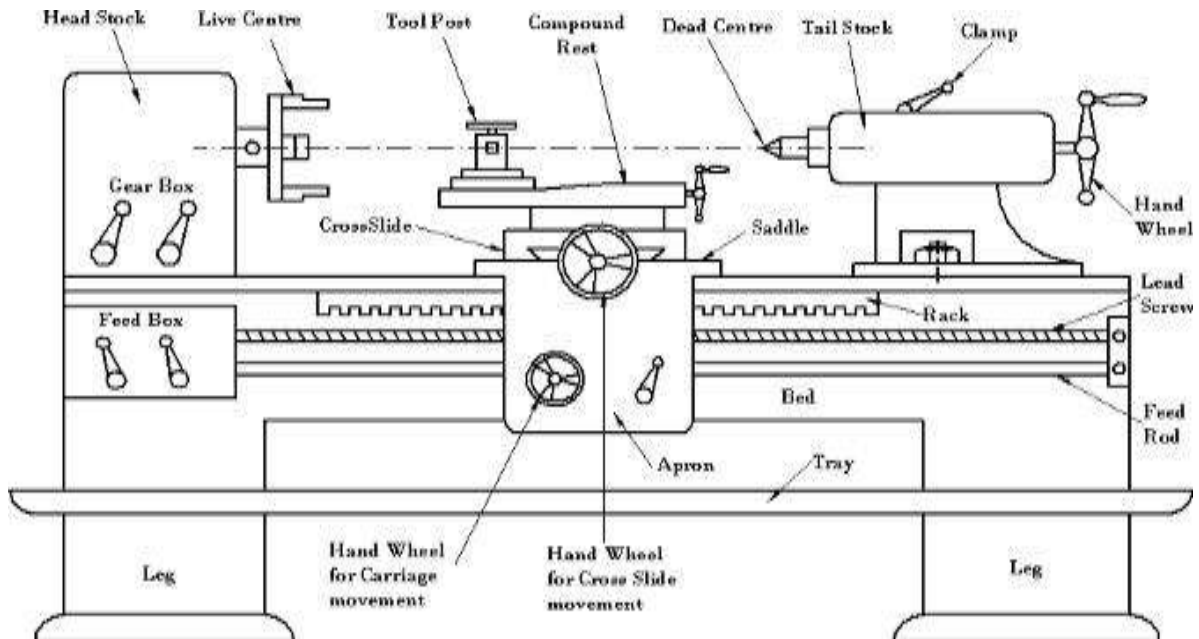

Fig. Parts of Lathe

- **Bed:** Usually made of cast iron. Provides a heavy rigid frame on which all the main components are mounted. It is the foundation part of a lathe and supports the remaining parts. The top of the bed is formed by precision-machined guide ways.
- **Guide Ways:** Inner and outer guide rails that are precision machined parallel to assure accuracy of movement.

- **Headstock:** mounted in a fixed position on the inner ways, usually at the left end. Using a chuck, it rotates the work. The housing comprising of the feed gearbox and the cone pulley called headstock of the lathe. The main spindle projects out from the headstock. The motor drives the cone pulley drives the main spindle through belting. Spindle speeds can be further varied using beek gear mechanism
- **Gearbox:** inside the headstock, providing multiple speeds with a geometric ratio by moving levers.
- **Spindle:** Hole through the headstock to which bar stock can be fed, which allows shafts that are up to 2 times the length between lathe centers to be worked on one end at a time.
- **Chuck:** allows the mounting of difficult work pieces that are not round, square or triangular. 3-jaw (self centering) or 4-jaw (independent) to clamp part being machined.
- **Tailstock:** Fits on the inner ways of the bed and can slide towards a headstock to fit the length of the work piece. Tail stock is the movable part of the lathe that carries the dead centre in it. The main function of the tailstock is to support the free end of the long work pieces. It is mounted loosely on the bed ways and can be moved in desired direction an optional taper turning attachment would be mounted to it.
- **Carriage Assembly:** Moves on the outer ways. Used for mounting and moving most the cutting tools. The carriage assembly consists of.
 - ✓ **Saddle:** is a H-shaped casting slides over the outer set of guide ways and serves as the base for the cross slide.
 - ✓ **Cross slide:** is mounted on the saddle and enables the movement of the cutting tool laterally across the lathe bed by means of cross-feed hand wheel.
 - ✓ **Compound Rest:** is mounted on the top of the cross slide and is swiveled to any angle in the horizontal plane to facilitate taper turning and thread cutting operations.
 - ✓ **Apron:** is mounted in front of the saddle beneath it and houses the carriage and cross slide mechanisms.
 - ✓ **Tool Post:** is mounted in the T-Slot of the compound rest and properly clamps the cutting tool.
 - ✓ **Feed Rod:** Has a keyway, with two reversing pinion gears, either of which can be meshed with the mating bevel gear to forward or reverse the carriage using a clutch. is a stationary rod mounted in front of lathe bed and facilitates longitudinal movement of the carriage
 - ✓ **Lead Screw:** is the screw rod that runs longitudinally in front of the lathe bed. The gyration of the lead screw moves the carriage to and fro longitudinally during thread cutting operations.

1.14.2 Specification of Center Lathe:

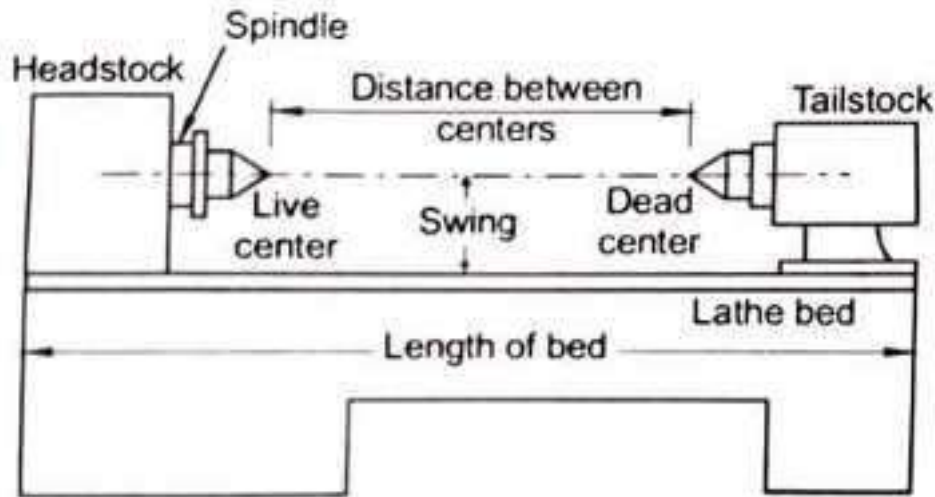

Fig. Specification of Center Lathe [2]

- **Distance between Centers:** The maximum length of the job that can be held between the live center and dead center.
- **Swing diameter:** It is the maximum diameter of the workpiece that can revolve without touching the guide ways.
Some manufactures specify Height of centers instead of swing diameter.
Height of centers: It is the height measured from the bed to the lathe center axis.
- **Length of bed:** Indicates the approximate floor space occupied by the lathe
- **Range of spindle speeds**

Important elements to work on LATHE

1. **Rotating Speed:** It expresses with the number of rotations (rpm) of the chuck of a lathe. When the rotating speed is high, processing speed becomes quick, and a processing surface is finely finished. However, since a little operation mistakes may lead to the serious accident, it is better to set low rotating speed at the first stage.
2. **Cutting Depth:** The cutting depth of the tool affects to the processing speed and the roughness of surface. When the cutting depth is big, the processing speed becomes quick, but the surface temperature becomes high, and it has rough surface
3. **Sending Speed (Feed):** The sending speed of the tool also affects to the processing

speed and the roughness of surface. When the sending speed is high, the processing speed becomes quick. When the sending speed is low, the surface is finished beautiful.

1.14.3 Lathe operations or Machining process on LATHE

The operations that can be performed on a lathe are

a) By holding the job between centers or between chuck and dead center

1. Turning – plain, step, taper, etc.
2. Facing
3. Chamfering
4. Knurling
5. Thread cutting
6. Thread cutting
7. Polishing
8. Spinning

b) By holding the job by a chuck alone

1. Turning and Facing of short-length work piece.
2. Drilling
3. Reaming
4. Boring
5. Thread cutting, internal/external.

c) By using special attachments.

1. Grinding
2. Milling

I. Plain Turning or Cylindrical Turning

- The process of metal removal from the cylindrical jobs is called straight or plain turning. It is a machining process for producing a cylindrical surface on the workpiece as shown figure below.
- The work-piece is supported in-between the two centres which permit the rotation of the work-piece. A single point cutting tool is fed perpendicular to the axis of the work-piece

to a known predetermined depth of cut, and is then moved parallel to the axis of the work-piece.

- Cross-slide and the carriage are used to perform turning operations and make the operation faster and economical. Plain turning operations are generally performed in two steps-rough and finish turning.
- Rough turning is usually done for rolled, cast, or forged parts to remove the uneven or sandy, or rough surface on the jobs. A roughing tool does roughing and used for excess stock removal. For finishing a tool with a slightly round cutting edge is used. The depth of cut rate is at the range of 0.2 to 1 mm and the feed rate between 0.1 to 0.3 mm.

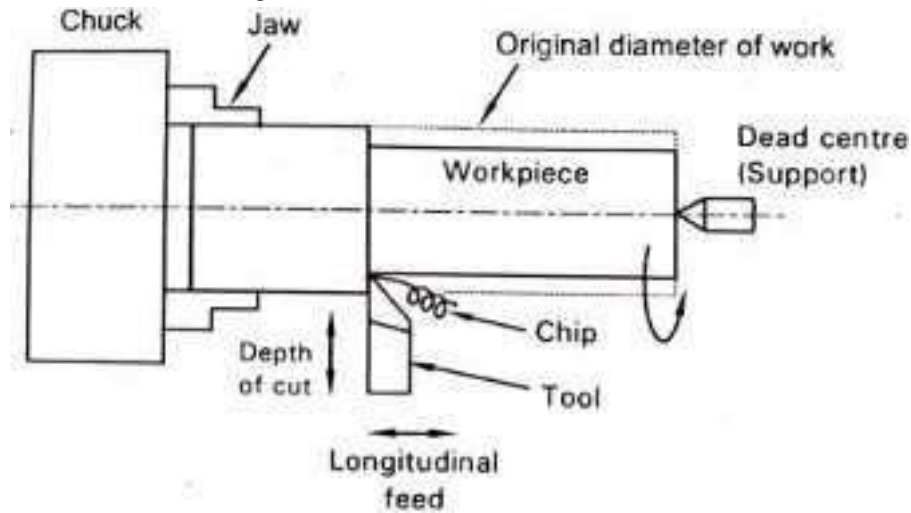

Fig. Cylindrical Turning

II. Facing

- Facing is a machining process for producing a flat surface at the end face of the workpiece as shown in figure below.
- Is the operation of machining the ends of a piece of the work to produce a flat surface square with the axis.
- This is used to cut the work to the required length. The operation involves feeding the tool perpendicular to the axis of rotation of the workpiece.
- A regular cutting tool may be used for facing a large workpiece. The cutting edge should be set at the same height as the center of the workpiece. A properly ground-facing tool is mounted in a tool holder in the tool post to accomplish facing operation.

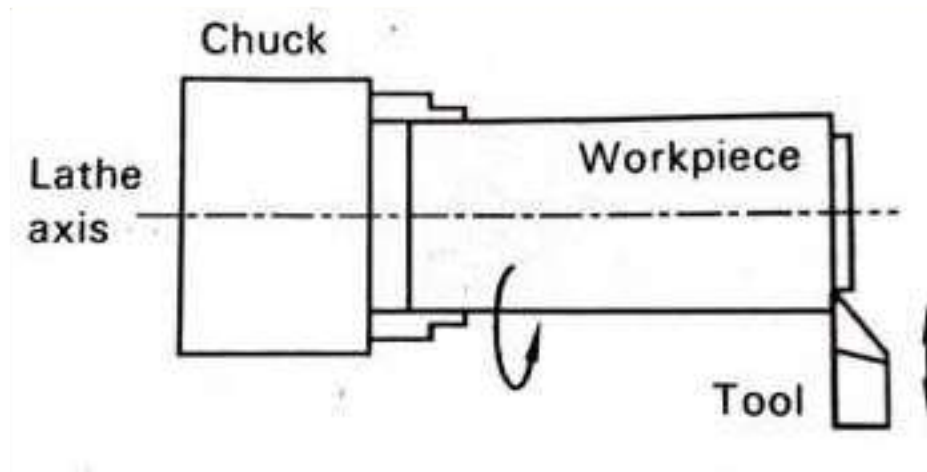

Fig. Facing

III. Taper Turning

- Taper turning is a machining process for producing conical surface on a cylinder workpiece as shown figure below.
- The work piece is held rigidly between the two supports of the machine and the cutting tool is fed against the revolving workpiece at an angle to the lathe axis. operation on a lathe to produce conical surface on the work pieces.

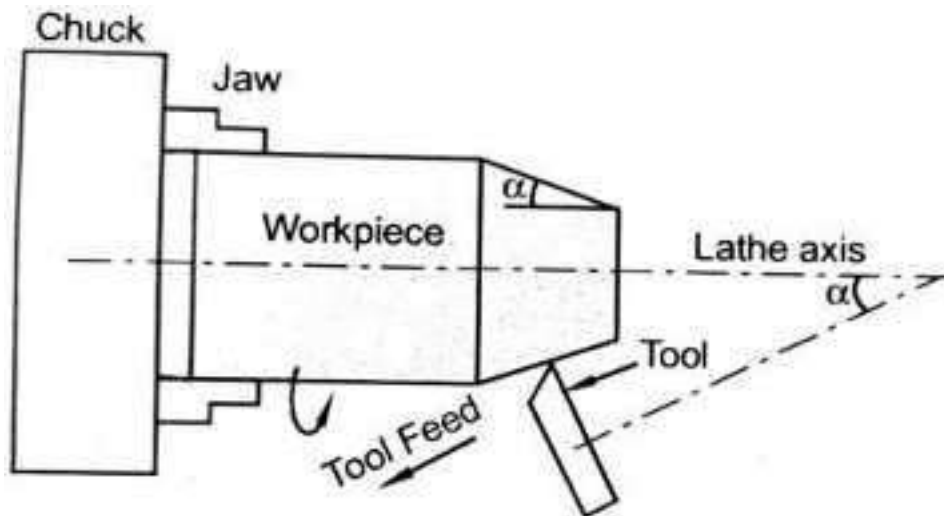
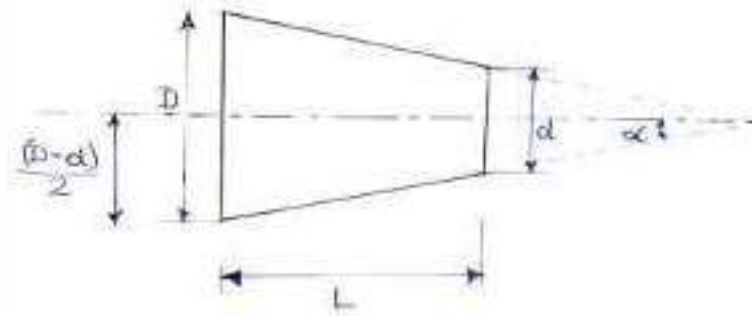

Fig. Taper Turning



Where, D = Bigger diameter of the taper (mm)
 d = Smaller diameter of the taper (mm)
 L = Length of the taper (mm)

= Half – tapered angle —

Half – tapered angle is calculated using the equation:

$$\tan \alpha = \frac{(D-d)}{2L}$$

$$\alpha = \tan^{-1} \left(\frac{(D-d)}{2L} \right)$$

Half – tapered angle =

METHODS OF TAPER TURNING.

- a. Swivelling the compound rest.
- b. Offsetting the Tailstock
- c. Taper turning attachment method.
- d. By using form tool.

a. Taper turning by Swivelling the compound rest.

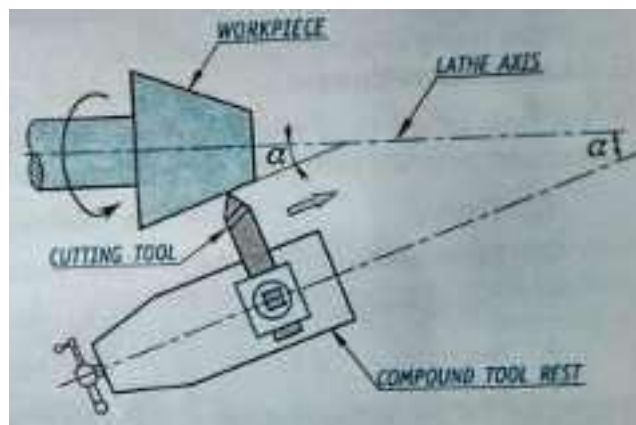

- In this method compound rest is swiveled to the required taper angle and then locked in the angular position.
- The carriage is also locked in that position
- For taper turning the compound rest is moved linearly at an angle so that the cutting tool produces the tapered surface on the workpiece.
- This method is suitable for limited lengths due to the limited movement of compound rest

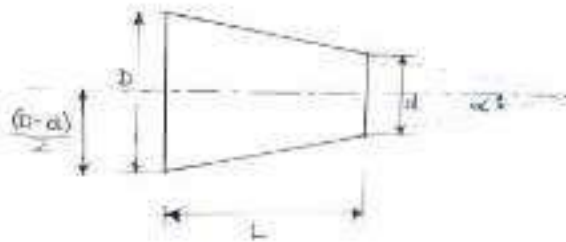

Where, D = Bigger diameter of the taper (mm)
 d = Smaller diameter of the taper (mm)
 L = Length of the taper (mm)

= Half – tapered angle

Half – tapered angle is calculated using the equation:

$$\tan = \left(\frac{D-d}{2L} \right)$$

$$\text{Half – tapered angle} = \tan^{-1} \left(\frac{D-d}{2L} \right)$$

b. Taper turning by offsetting the tailstock

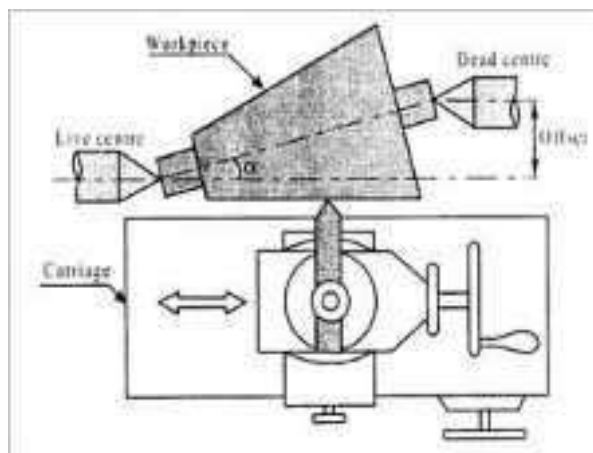

- This method is also known as setover tailstock method.
- In this method the tailstock center is set out of alignment, the workpiece gets taper because its axis will be inclined at an angle with the longitudinal movement of the tool which will be parallel to the lathe bed.
- The cutting tool is fed parallel to the lathe axis and the desired taper is produced.

c. Taper Turning by Taper Turning Attachment

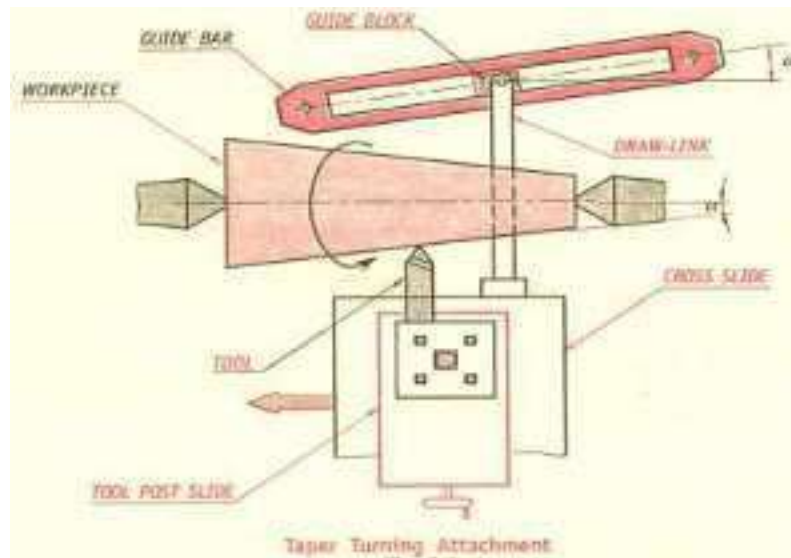

- A taper turning attachment is used to cut both internal and external tapers.
- The taper turning attachment shown in Fig. consists of a bracket (not shown in figure) which will be connected to the rear side of the lathe bed.
- A guide bar which can be swiveled in the horizontal plane and locked in position, is mounted over the bracket.
- A guide block pivoted to a draw-link will slide in the longitudinal slot in the guide bar. The draw-link is connected firmly to the cross slide.
- The tool is mounted on the tool post slide. The cross slide is allowed to move freely on its ways by loosening the cross feed screw and the engaging nut.
- When the carriage is moved, the guide slides inside the slot in the guide bar.
- The sliding of the guide inside the slot forces the cross slide to move in the traverse direction.
- The combined traverse motion of the cross slide and the longitudinal motion of the carriage moves the tool parallel to the inclined axis of the guide bar and produce the required taper on the workpiece.

d. Taper Turning by a Form Tool

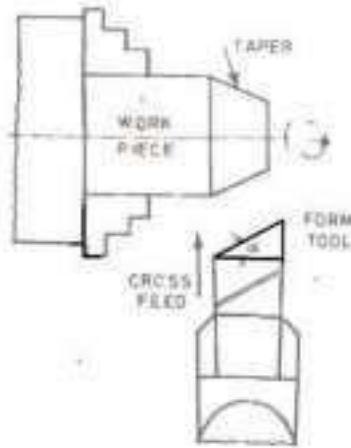

- The taper turning by using a broad nose form tool
- Method is suitable only for very short tapers (max. 20mm length)
- Form or broad-nose tool is used [cutting edge is ground to contain half taper angle]
- During operation, lot of vibrations are caused as full cutting edge is involved in cutting.

IV. Thread Cutting:

- Thread cutting or threading is a machining process for cutting screw threads on metallic parts as shown in the figure below.
- A thread is a helical ridge formed on the cylindrical rod surface. By employing a V-Shaped cutting tool it is possible to accomplish threads on the workpiece.
- In operation, a suitable tool which gives the required thread profile, say V-thread, square thread etc., is mounted on the tool post of the lathe.
- The workpiece is made to revolve at a very slow speed with uniform motion.
- The depth of cut is selected and the tool is made to move parallel to the lathe axis by means of automatic arrangements. (An appropriate gear ratio is maintained between the spindle on which the work piece is mounted and the lead screw)
- Thread cutting is carried out in a number of passes. The final cut is a finishing cut with a very small depth of cut in order to obtain a good surface finish.

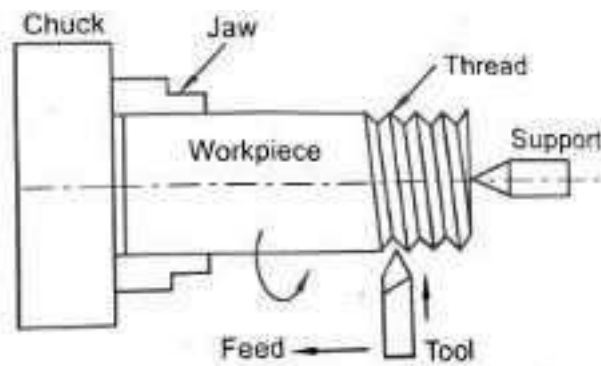

Fig. Thread cutting

V. Knurling:

- Knurling is an operation performed on the lathe to generate serrated surface on the work piece. This is used to produce a rough surface for gripping like the barrel of the micrometer or screw gauge. This is done by a special tool called knurling tool which has a set of hardened roller with the desired serrations. As shown in figure (a) and figure (b)
- During knurling operation, the hardened rollers of the tool are pressed against the slowly rotating work pieces such that the impression of tool serrations are formed on the work pieces surface.
- Usually, there are three different pattern of knurling produced as per requirements and is as shown.

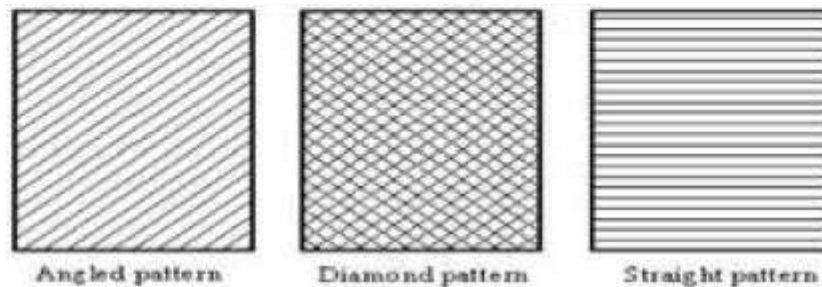
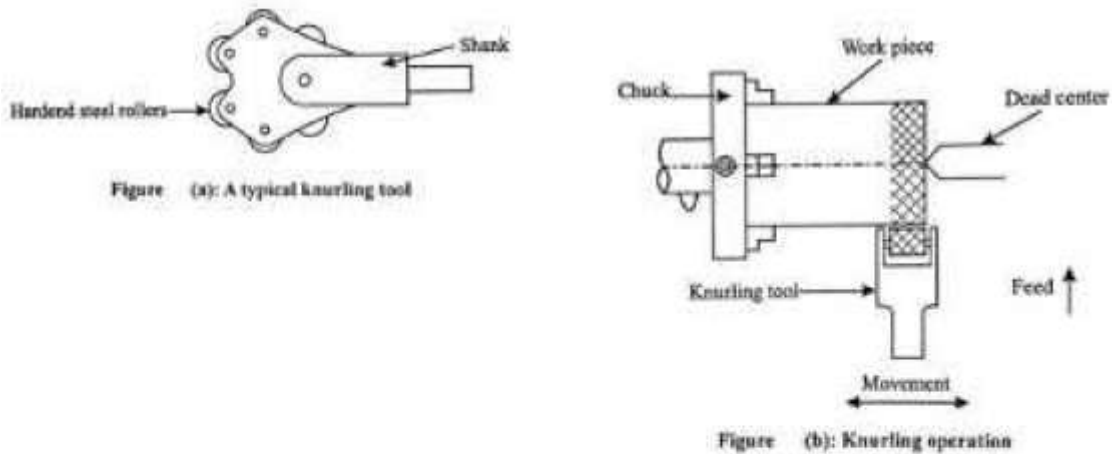

Fig. (c) different pattern of knurling produced

VI. Drilling on lathe:

- Drilling is the operation of producing a cylindrical hole by means of a revolving tool called twist drill or drill bit.

- In operation, one end of the workpiece is held in chuck, The tool is held in the tapered hole of the tailstock sleeve and is fed into the rotating workpiece with the help of rotating hand wheel of the tailstock.
- Drilling on lathe is limited to holes through the axis of rotation of the workpiece and from any of the ends only.

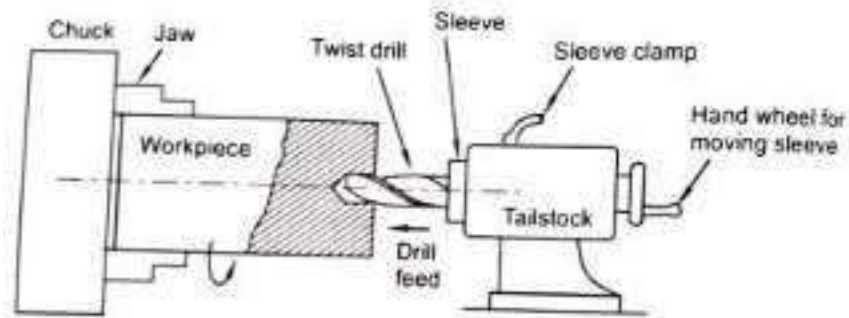

Fig. Drilling on lathe [2]

1.15 LATHE ACCESSORIES

Lathe accessories are tools and equipment's used for holding and supporting the workpiece., and also for holding the tool rigidly during machining.

The common lathe accessories used in lathe are illustrated in figure and briefed as below

- Lathe Centers
- Lathe chuck
- Lathe dog
- Drive plate
- Face plate
- Mandrel
- Steady rest
- Follower rest

- a) **Lathe centers:** Lathe centres are ideal for supporting long workpieces, such as shafts. The workpiece can be taken out of the lathe and flipped end for end without any loss of accuracy, assuming that the centres are in good condition. As shown in figure below

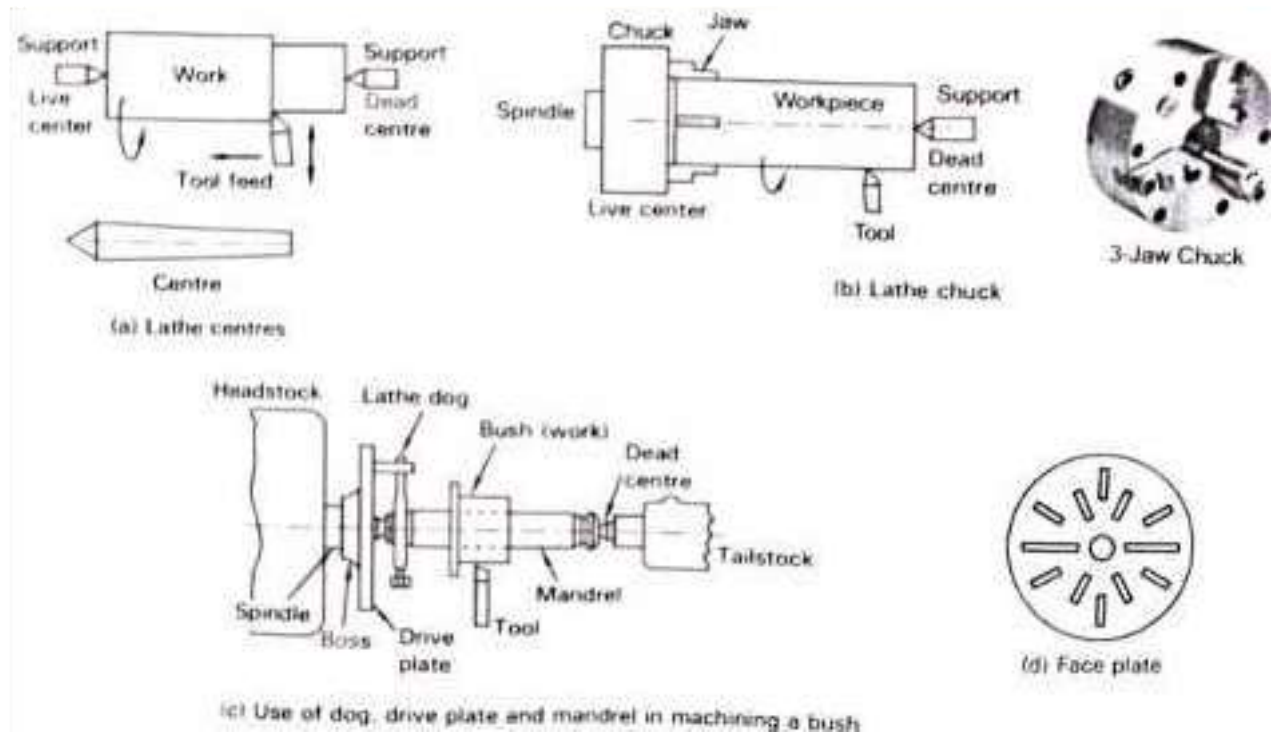

- b) **Lathe chuck:** A lathe chuck is a tool, which by means of its adjustable jaws, holds the work as well as rotates the workpiece so that the stationary cutting tool can perform machining operation, as shown in figure (b) above.
- c) **Lathe dog:** Lathe dogs are used to transmit drive power from the spindle to a workpiece when it is held between centres (Without a lathe dog, the workpiece stops turning as soon as the cutting tool is applied, as shown in figure (c) above
- d) **Drive plate:** A drive plate is a flat disc that attaches to the spindle nose. It has grooves and pins to engage and turn a lathe dog, as shown in figure (c) above
- e) **Face plate:** A faceplate is a large disc that may attach to the lathe spindle nose. It is similar to a drive plate, but is larger. Faceplates are used to hold oddly shaped workpieces that cannot be held in a chuck or between centres.
- f) **Mandrel :** A mandrel is used to grip a workpiece by its bore. Several types of mandrels are available. They are used when gripping a workpiece with jaws could mar the surface. Workpieces are held in mandrels by a shallow solid taper, a tapered sleeve or a nut on the threaded portion, as shown in figure (c) above.
- g) **Steady rest:** Long, thin workpieces present special problems for the lathe operator. A steady rest solves these problems by supporting the workpiece either at the end or in the middle. A steady rest is an optional piece of equipment supplied with most lathes.
- h) **Follower rest:** A long, thin workpiece tends to deflect away from the cutting tool during a cut. The deflection is greater in the middle of the workpiece than at either end, which results in a diameter that is not uniform

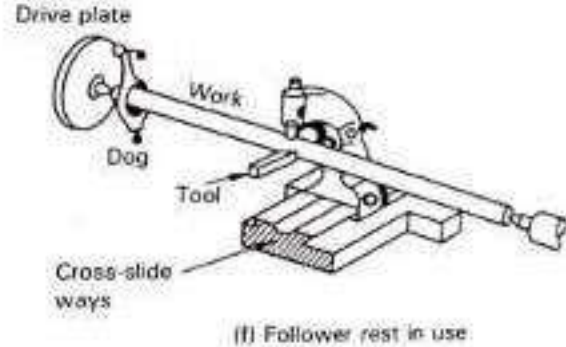
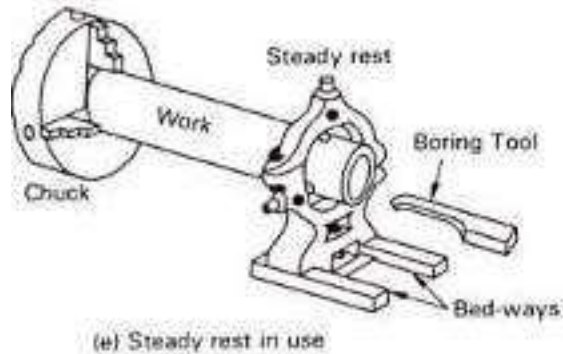

1.16 KINEMATICS OF LATHE

- Kinematics is a branch of science which deals with relative motion of bodies without considering the forces causing the motion.
- In a turning operation carried on a manual lathe, the movement (rotation) of the workpiece forms the primary motion while the linear movement of the cutting tool forms the feed or secondary motion.
- The movement or rotation of the workpiece is controlled with the help of machine tool drives, i.e., the motion is transmitted from the power source to the workpiece in a controlled manner. The cutting tool is fed manually by the operator
- The work piece takes the rotational power from the electric motor through the belt-pully, clutch and then the speed gear box which splits the input speed into a number of speeds by operating the cluster gears.
- While cutting screw threads on workpiece, the half nut is engaged with the rotating lead-screw to positively cause travel of the carriage and hence the tool parallel to the lathe bed or axis of the workpiece.
- The feed rate for both turning and threading is varied as required by operating the Norton gear and the main drive systems existing in the feed gear box. The range of feeds can be increased by changing the gear ratio in the gear quadrant connecting the gear box with the spindle.

1.17 CAPSTAN & TURRET LATHE

Capstan and Turret lathes are semi-automatic machines, equipped with special tooling facilities capable of accommodating around 6 to 8 cutting tools that can be fed into the workpiece in a proper sequence. Also, the positive stops or feed trips located on the machine help the operator to carry out the machining operation independently without the necessity for making measurements on the workpiece length each time. Such a facility avoids re-setting of work or tools, thereby reducing time and labour. The details regarding the lathes are briefed as follows.

1.17.1 Saddle Type Turret Lathe

Saddle Type Turret Lathe as shown in figure below, is basically suited for heavy-duty jobs, particularly those requiring long and accurate cuts. The consists of the following parts.

- a) **Bed:** The bed is a long, box-like casting with rectangular guideways upon which are mounted the carriage and turret saddle. It also supports the headstock and other parts of the machine. The bed provides strength and rigidity to all the parts of the machine during its operation.
- b) **Headstock:** The headstock mounted on the left end of the bed houses the powerful motor and transmission mechanism like gears, which operates the spindle to rotate at various speeds
- c) **Turret and turret saddle:** In a turret lathe, there is no tailstock; instead, a hexagonal indexable turret (turret head or tool holder) is mounted on saddle, which slides longitudinally on the bed. The turret is a hexagonal (six sided) block with a through hole machined on each face of the hexagon into which the shank of six different tools may be accommodated and clamped by means of screws provided on the top the turret. The turret may be indexed (rotated through fixed angle) automatically or manually to bring each tool in proper position for performing the operation on the work piece.

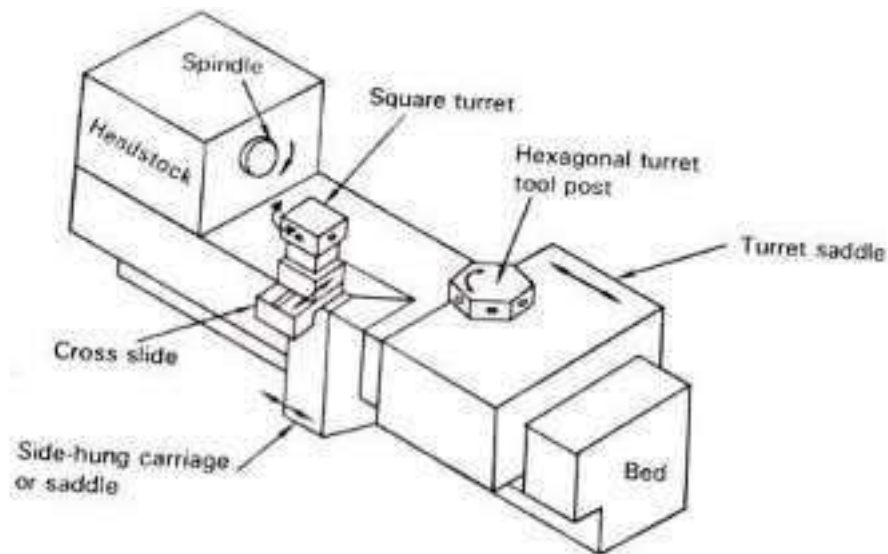

Fig. (a) Pictorial view of a saddle-type turret lathe [2]

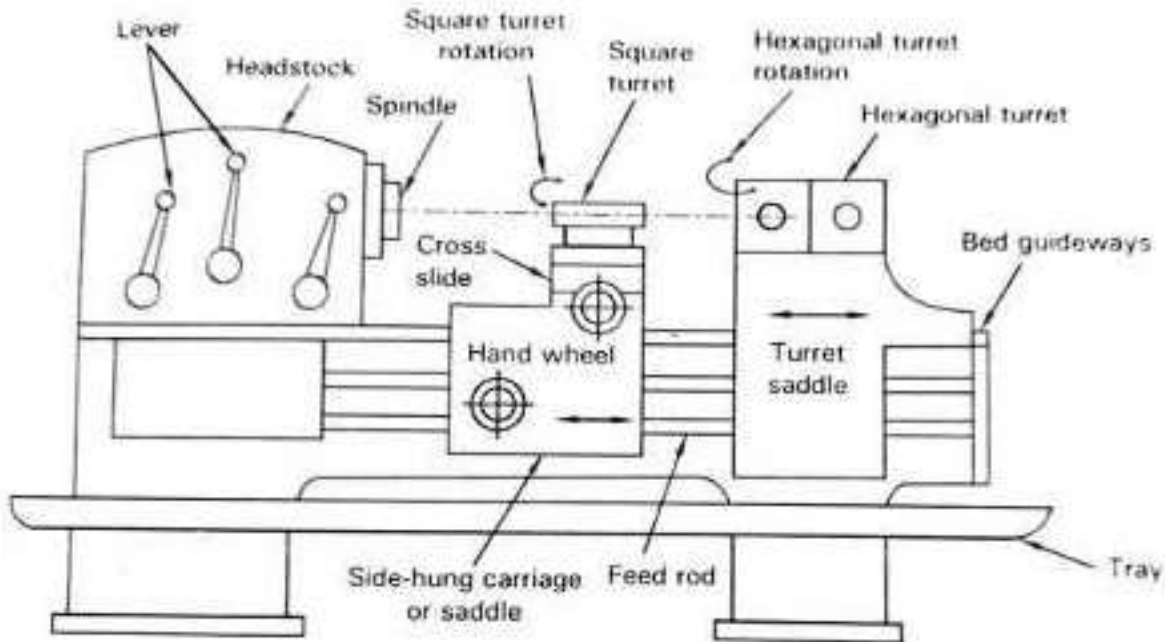

Fig. (b) Front view of saddle type Turret Lathe

- d) **Cross-slide and square turret:** The cross-slide is mounted over the chaser saddle, which is of a side-hung type supported on the front bedways, and on an additional way provided on the front of the bed near its bottom. The chaser saddle can slide longitudinally on the bedways of the machine through power or manual operation. The cross-slide carries a square turret tool post capable of holding four different single point cutting tools. The square turret is indexed manually about a vertical axis to bring each of the four tools into operating position. It can also move in transverse direction (perpendicular to the spindle axis) on the cross-slide.
- e) **Feed rod:** It controls the motion for the side-hung carriage during thread cutting and other related operations.
- f) **Legs:** Legs are hollow castings, acting as supports, carrying the entire load of the machine over them. They are firmly secured to the floor by means of foundation bolts in order to prevent vibrations of the machine during operation. The left leg accommodates in it several mechanisms like electrical, drives, oil pump, etc.

1.17.2 Capstan Lathe or Ram Type Turret Lathe

The modern name for a capstan lathe used in industries is a ram type turret lathe. The capstan lathe is similar in appearance to the saddle type turret lathe, except regarding the features of the saddle and cross-slide, which forms the main basis of difference between the two types of lathes. The capstan lathe is so called, because of the tool head carrier, the turret being circular shaped instead of hexagon. However, in some machines, the tool head is designed to have a hexagonal shape also, Figure. shows the features of a capstan lathe. The machine consists of the following parts:

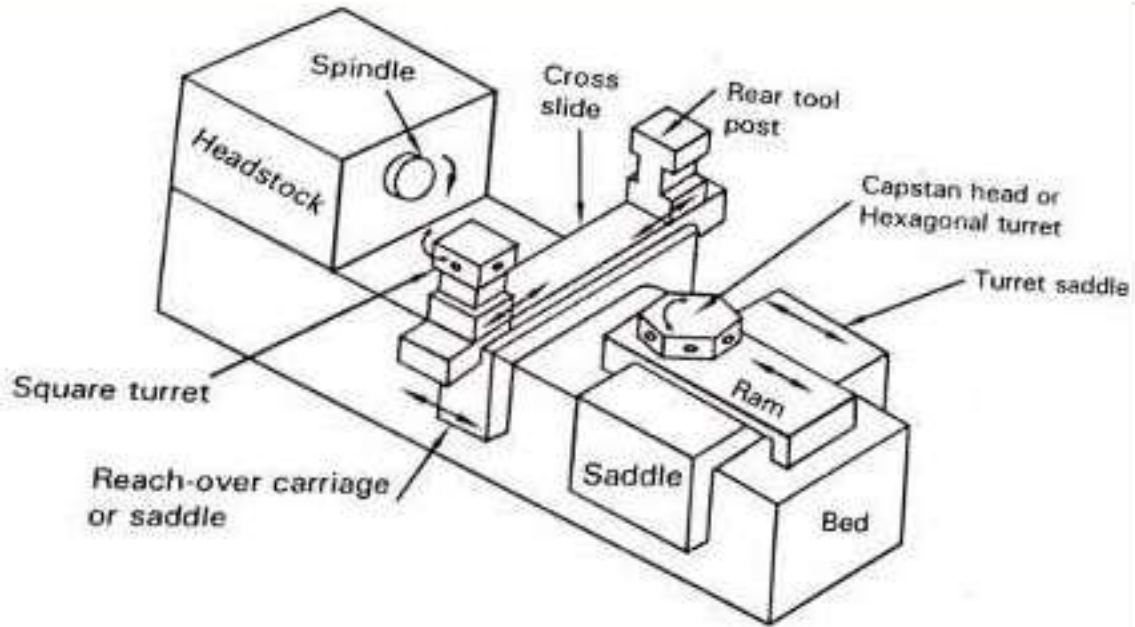

Fig. (a) Pictorial view of a ram-type turret lathe (capstan lathe)

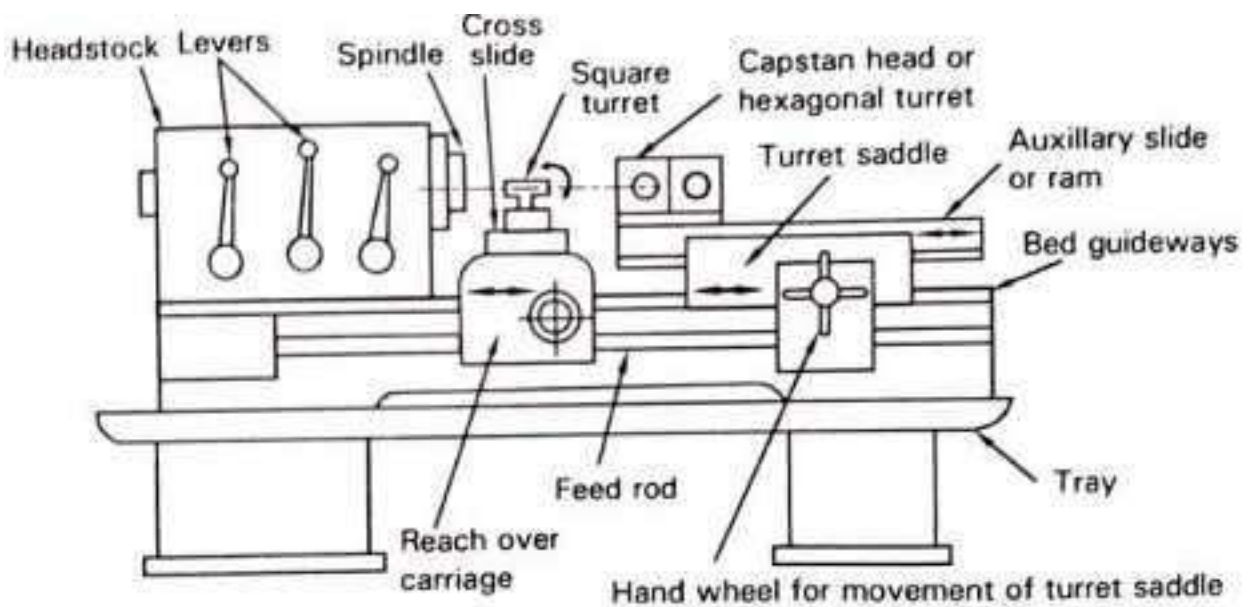

Fig. (b) Front view of capstan lathe or Ram-type turret lathe [2]

- a) **Bed:** The bed is a long, box like casting with rectangular guideways upon which are mounted the carriage and turret saddle. It also supports the headstock. The bed provides strength and rigidity to other parts of the machine.
- b) **Headstock:** It is a large casting mounted on the left end of the bed. Generally, an all-gear headstock is used for rapid change of the spindle speeds. This should be selected prior to an operation by changing the lever or pressing the speed changing button.

- c) **Turret saddle:** The saddle in a capstan lathe supports an auxiliary slide called **ram**, which in turn supports the capstan head (turret) on a vertical spindle. The capstan head is a circular shaped block with through holes machined around its periphery to accommodate around six tools of different types. The carrying the capstan head slides longitudinally on the turret saddle feeding the tools against the workpiece.
- Further, the saddle in a capstan lathe can be moved along the bedways and secured at any desired position in order accommodate work piece of different lengths. The turret or capstan head can be moved manually by means of hand wheel or through power feed mechanism.
- d) **Cross-Slide:** It is mounted over the chaser saddle, which is of a **reach over type** or bridge type that can slide longitudinally on the bedways between the headstock and the turret saddle. The cross-slide carries a square turret tool post capable of holding four different single point cutting tools. The advantage of **reach over type saddle** over the **side-hung saddle** as used in saddle type turret lies in the availability of an additional tool post at the rear end, which also can carry around four cutting tools for various operations. The square turret tool post at the front, and the tool post at the rear can be moved in the transverse direction on the cross-slide.
- e) **Feed rod:** The feed rod controls the motion for the reach-over saddle during thread cutting and similar such operations.
- f) **Legs:** Legs are hollow castings, acting as supports, carrying the entire load of the machine over them. They are firmly secured to the floor by means of foundation bolts in order to prevent vibrations of the machine during operation. The left leg accommodates in it several mechanisms like electrical, drives, oil pump, etc.

1.17.2 Specification of Capstan/Turret Lathe

The size of the Capstan/Turret lathe is specified by one or more of the following criteria.

- Maximum diameter of the workpiece that can be revolved
- Maximum diameter of the workpiece that can be passed through the headstock spindle.
- Power of main drive motor.
- Range of spindle speeds
- Range of longitudinal and cross-feed rates.
- Type of chucking (pneumatic, hydraulic, etc.,) and chuck size.

1.17.2 Difference Between Capstan and Turret Lathe [2]

Sl. No.	Turret Lathe	Capstan Lathe
1.	The turret head is mounted on a saddle, which slides directly on the bedways of the machine	The turret or capstan head is mounted on an auxiliary slide called ram, which slides on the guideways provided on the saddle
2.	The entire saddle unit is moved for feeding the tools against the rotating work.	The saddle is fixed at a convenient distance from the work and the tools are fed by moving the ram.
3.	Manual movement of the entire saddle for feeding the tools is a tedious process.	The capstan head can be moved back and forth easily without having to move the entire saddle unit.
4.	The cutting forces of the hexagonal turret head are transferred to the rigid lathe bed. Hence, heavy jobs involving high cutting forces can be machined.	The cutting forces of the capstan head are transferred to the auxiliary slide – ram, which is not rigid as the lathe bed. Hence heavy cuts may result in deflection or vibrations of the ram. This makes the machine suitable only for small and light jobs.
5.	Turret lathe may carry either a reach-over type or side-hung type carriage/saddle.	A capstan lathe can carry only reach-over type saddle.
6.	Capable of turning workpieces up to 200 mm in diameter.	Capable of turning workpieces up to 60 mm in diameter.

2.1 INTRODUCTION TO MILLING

- Milling is a process of shaping work materials by feeding the work material against a multipoint rotating cutter. As shown in figure 1(a).
- The machine used for the purpose is called milling machine. Milling can be used for producing flat, angular or curved surfaces, for cutting threads, toothed gears, keyways, slots, and a wide variety of other operations.
- The milling cutter is a multipoint cutting tool. The work piece is mounted on a movable worktable which will be fed against the revolving milling cutter to perform the cutting operation.
- A milling machine is a power operated machine tool in which the work piece mounted on moving table is machined to various shapes when moved under a slow revolving multipoint cutter.
- The difference between drilling and milling is that, in drilling a rotating drill is fed against a stationary work piece, while in milling the work piece is fed against a milling cutter which only revolves.
- Similarly, it also differs from the lathe operation because the lathe tool is fed against rotating work piece.

- It can also perform drilling and boring operations. The type of cutter used in milling depends on the shape desired on the workpiece. Figure 1 (b) shows the various shapes produced by milling. Milling is a metal cutting operation in which the operating tool is a slow revolving cutter having cutting teeth formed on its periphery

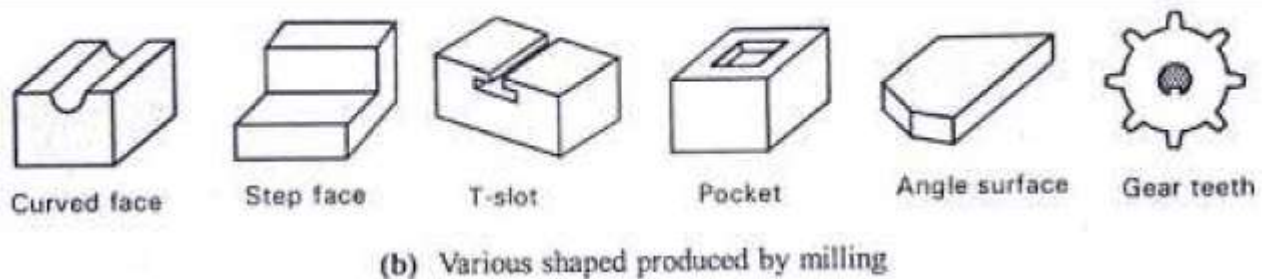
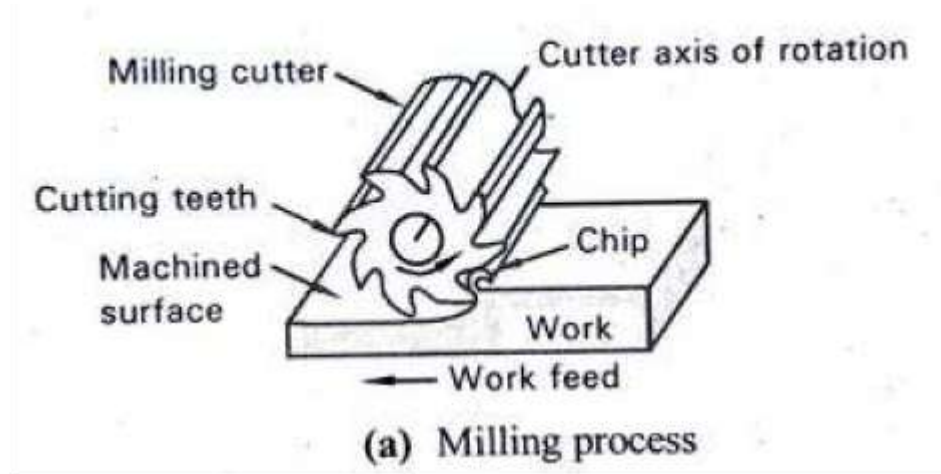

Fig. 1(a), 1(b).

2.2 The Principle of Milling

- In milling, the cutter is held in the spindle of the machine and made to rotate at suitable speeds.
- The workpiece is also held rigidly by a suitable device and is fed slowly against the rotating cutter.
- The workpiece can be fed in two different directions with respect to cutter rotation as shown in figure. below the process thus gives a means of classification of milling into two types known as up milling and down milling.
- In up milling process as shown in figure 2(a), the workpiece is fed in the direction opposite to that of the rotating cutter, while in down milling process as shown in figure 2(b), the workpiece is fed in the same direction as that of the rotating cutter. The various aspects related to the two types are tabulated in a comparison form in table 1.

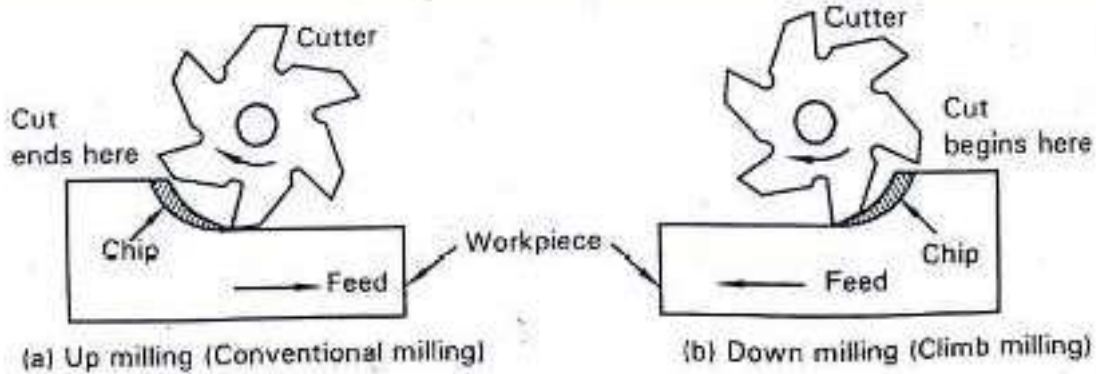
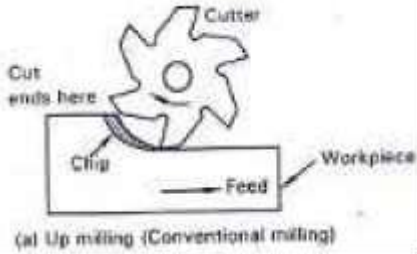
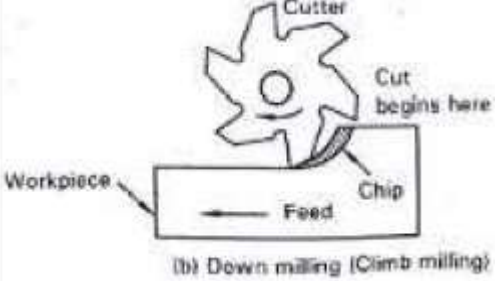

Fig. 2(a), 2(b)

2.2.1 Comparison between Up Milling and Down Milling

Sl. No.	Up milling (Conventional milling)	Down milling (Climb milling)
1.	In up milling, the workpiece is fed in the direction opposite to that of the rotating cutter.	In down milling, the workpiece is fed in the same direction as that of the rotating cutter.
2.	The thickness of chip is minimum at the beginning of cut and reaches to a maximum when the cut ends.	The thickness of chip is maximum at the beginning of cut and reaches to the minimum when the cut ends.
3.	In up milling, the cutting force is directed upwards. This tends to lift the workpiece from the worktable. Hence, greater clamping force for the workpiece becomes necessary.	The cutting force is directed downwards, and this tends to keep the workpiece firmly on the worktable thereby permitting lesser clamping forces.
4.	During up milling, the chip gets accumulated at the cutting zone (tool-work interface). These chips interfere with the rotating cutter thereby impairing the surface finish on the work-surface.	In down milling, the chips do not interfere with the revolving cutter, since they are disposed easily by the cutter. Hence, there is no damage to the surface finish of the workpiece.
5.	In up milling, it is difficult for efficient circulation of coolant. The cutter rotating	In down milling, the coolant can easily reach the cutting zone. Hence, efficient cooling of the tool and the workpiece can be achieved.

	in the upward direction carries away the coolant from the cutting zone.	
6.	Up milling is preferred for rough cuts, especially for castings and forgings, because this method enables the cutter to dig-in and start the cut below the hard upper surface.	Down milling produces better surface finish because there is no dig-in of the cutter. It is particularly used for finishing operations and small work like cutting slots, grooves etc.
	 <p>(a) Up milling (Conventional milling)</p>	 <p>(b) Down milling (Climb milling)</p>

2.3 TYPES OF MILLING MACHINES

The different types of milling machines are listed as follows.

- i. Column and knee milling machines.
 - a) Plain column and knee type milling machines
 - Horizontal spindle type
 - Vertical spindle type
 - b) Universal Column and knee type milling machine
- ii. Bed type milling machines
- iii. Planer type milling machine
- iv. Special purpose milling machines
 - a) Tracer-controlled milling machine
 - b) Thread milling machine.
 - c) CNC milling machine.

2.3.1 Horizontal Spindle Column & Knee Milling Machine

It is one of the most popular type of milling machine, and is commonly called horizontal milling machine, because of the horizontal position of the spindle. This type of machine is used to cut grooves, slots, keyways, gear teeth etc. figure (a) shows one of the principal views of a horizontal milling machine. Figure (b) shows the pictorial view of the same.

The machine consists of the following parts:

- a) **Base** is usually a strong and a hollow part which forms the foundation of the machine and upon which all the other parts are mounted. The base also serves as a sump for the cutting fluid. A pump and filtration system can be installed in the base. The hole provided in the center of the base, houses the support for the elevating screw that raises and lowers the knee.
- b) **Column** is a vertical hollow casting and is usually combined with the base to form a single casting. The column houses the spindle and bearings as well as the drive units (gears, clutches, shafts, and shifting mechanisms) for transmitting power from the electric motor to the spindle at desired speeds. The front face of the vertical column is provided With a square or dovetail type guideways on which the knee slides up and down.
- c) **Spindle** is a hollow shaft supported by the column with suitable bearings that absorb both radial and thrust loads. The spindle is made hollow and tapered inside to accept standard arbors. The spindle obtains power from the motor and transmits it to the arbor. The arbor carrying the cutter rotates about a horizontal axis.
- d) **Overarm** mounted on the vertical column supports the yoke, which in tum supports the free end of the arbor.
- e) **Knee** is a casting that slides up and down on the vertical guideways provided on the column by means of an elevating screw. The knee supports the saddle.

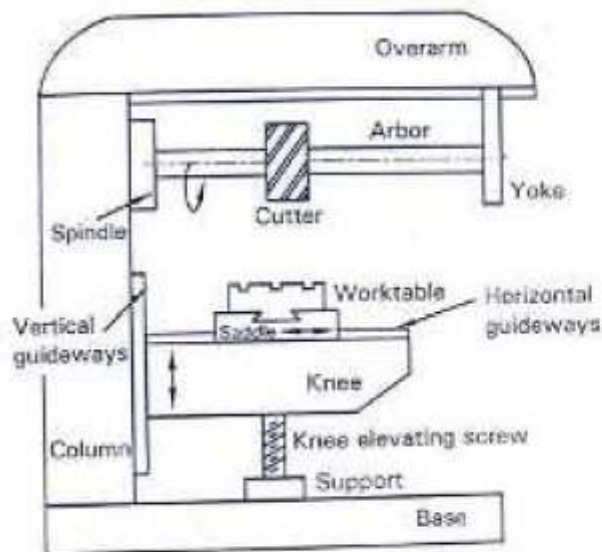

(a) End view of a horizontal-spindle column and knee milling machine

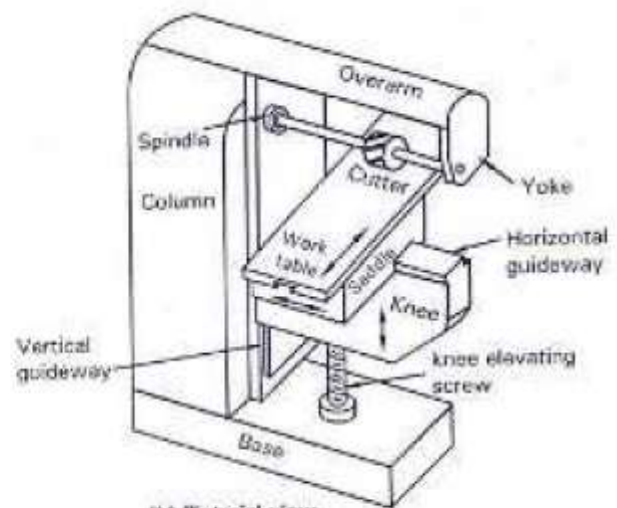

(b) Pictorial view

Note: Hand wheel for providing motions to knee, saddle and table are not shown in figure.

Fig. Horizontal-spindle column and knee milling machine.[2]

- f) **Saddle** mounted on the knee is provided with two slides (guideways) on its top and bottom surfaces. The slides are machined at right angles to each other. The lower slide fits the slide provided on top of the knee and facilitates horizontal movement of the saddle. The upper slide provided on the saddle accepts the slide provided on the bottom surface of the worktable.
- g) **Worktable** is larger in size and rests on the saddle. The bottom surface of the table has a dovetail slide that fits in the slide on the top surface of the saddle. This arrangement facilitates the worktable to be moved longitudinally or at right angles to the movement of the saddle. The worktable is provided with T-slots all along its length for mounting vice or other work holding devices. This enables the workpiece to be clamped rigidly on the table. The worktable may be manually controlled or power fed. A dial graduated in thousandths of an inch (not shown in figure) is provided to allow for accurate table movement and placement.

2.3.2 Vertical Spindle Column and Knee Milling Machine

- Vertical spindle milling machines are similar in construction to the horizontal milling machines, except that the spindle is held in a vertical position.
- This type of machine is generally used to perform end milling and face milling operations. Figure shows the principal parts of a vertical milling machine.

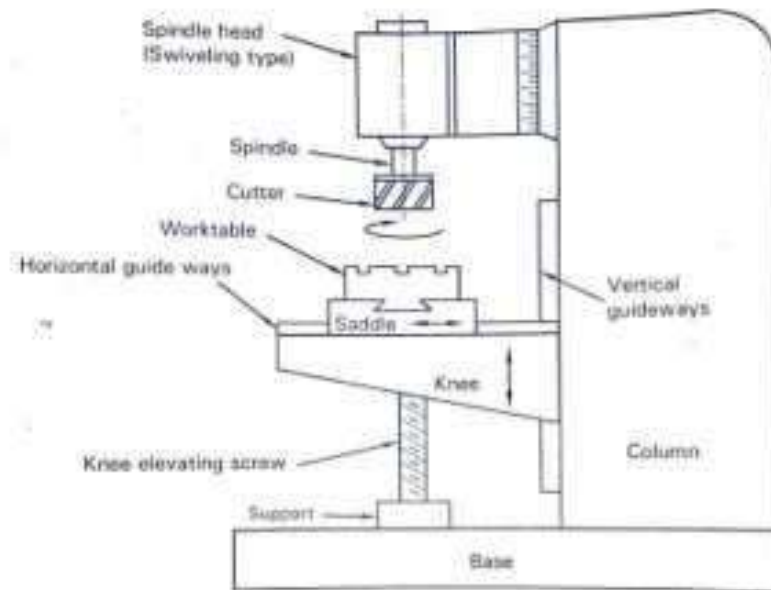

Fig. Vertical spindle column and knee type milling machine (swiveling type)[2]

The machine consists of the following parts:

- a) **Base** is usually a strong and a hollow part which forms the foundation of the machine

and upon which all the other parts are mounted. The base also serves as a sump for the cutting fluid. A pump and filtration system can be installed in the base. The hole provided in the center of the base, houses the support for the elevating screw that raises and lowers the knee.

- b) **Column** is a vertical hollow casting and is usually combined with the base to form a single casting. The column houses the spindle and bearings as well as the drive units (gears, clutches, shafts, and shifting mechanisms) for transmitting power from the electric motor to the spindle at desired speeds. The front face of the vertical column is provided With a square or dovetail type guideways on which the knee slides up and down.
- c) **Spindle** is located vertically, parallel to the face of the column, and perpendicular to the top of the worktable. The spindle is mounted in the spindle head and carries the cutter at its end. The spindle head houses the motor & feed controls & can be either fixed type or swiveling type.

In fixed type, the spindle head is fixed, and hence the spindle remains vertical. The spindle can be adjusted up and down to perform operations like grooving, slotting, facing, drilling and boring. While, in swiveling type, the spindle head can be swiveled to any angle to the surface of the worktable. This permit working on angular surfaces of workpieces.

- d) **Overarm** mounted on the vertical column supports the yoke, which in tum supports the free end of the arbor,
- e) **Knee** is a casting that slides up and down on the vertical guideways provided on the column by means of an elevating screw. The knee supports the saddle.
- f) **Saddle** mounted on the knee is provided with two slides (guideways) on its top and bottom surfaces. The slides are machined atright angles to each other. The lower slide fits the slide provided on top of the knee and facilitates horizontal movement of the saddle. The upper slide provided on the saddle accepts the slide provided on the bottom surface of the worktable.
- g) **Worktable** is larger in size and rests on the saddle. The bottom surface of the table has a dovetail slide that fits in the slide on the top surface of the saddle. This arrangement facilitates the worktable to be moved longitudinally or at right angles to the movement of the saddle. The worktable is provided with T-slots all along its length for mounting vice or other work holding devices. This enables the workpiece to be clamped rigidly on the table. The worktable may be manually controlled or power fed. A dial graduated in thousandths of an inch (not shown in figure) is provided to allow for accurate table movement and placement.

2.4 Specification of Milling Machine

- The Milling machine is specified by one or more of the following criteria.
 - ✓ Type of spindle
 - ✓ Length & Breadth of the worktable
 - ✓ Power of driving motor
 - ✓ Number of spindle speeds
 - ✓ Spindle feed range
 - ✓ Taper of spindle nose, etc,

2.5 MACHINING PROCESSES ON MILLING MACHINE

A few machining processes on milling machine are discussed as follows .

a) Plain or Slab milling

- Plain milling, also called surface milling, peripheral milling or slab milling is a machining process for producing a plain horizontal surface with a milling cutter whose axis is parallel to the surface of-the workpiece being machined.
- Refer figure 1. The process is carried out on a horizontal milling machine with a cutter having straight or helical teeth* formed on the periphery of a cylindrical surface. The cutter is mounted on the arbor rotating at a suitable speed, while the workpiece is fed against the cutter causing material to be removed from the workpiece. A plain smooth surface can be produced with this process.

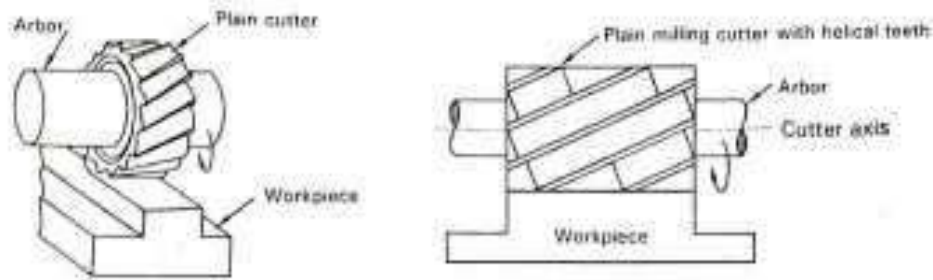

Fig. Plain/Slab milling [2]

b) Face milling

Face milling is a machining process carried out for producing a flat surface, which is perpendicular to the axis of the rotating cutter. Refer figure 2. The process is carried out on a vertical milling machine with a cutter called face milling cutter, having diameter larger than the width of the workpiece being machined, so that the surface can be finished in a single pass.

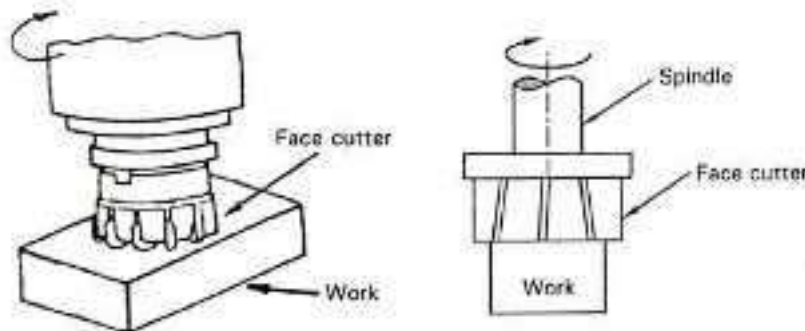

Fig.2 Face milling

c) End milling

End milling is a machining process carried out for producing flat surfaces, profiles, slots, grooves, or finishing the edges of the workpiece by means of a tool called end mill or end milling cutter. Figure 3 shows an end mining cutter having teeth on the end as well as the periphery (sides) for machining with both its end as well as its sides. The cutter usually rotates on an axis perpendicular to the work surface, although it can be tilted to machine tapered surfaces. End mills are also available with hemispherical ends (ball nose) for machining curved surfaces in metallic dies and moulds.

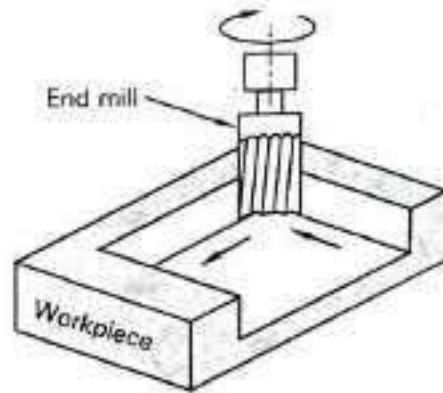

Fig.3 End milling

d) Slot milling

Slot milling is a machining process for producing slots like T-slots, plain slots, dovetail slots etc., in worktable fixtures and other work holding devices. The operation may be performed using either T-slot cutter end milling cutter, T-slot cutter, dovetail cutter, or side milling cutter. type of cutter selected depends on the shape of the slot to be produced, Figure 4. shows the operation of producing T-slot.

The separate milling cutters are required for milling T-slots. Initially, a plain cutter, side cutter or an end milling cutter is used to cut the throat (open slot) starting from one end of the workpiece to its other end. A T-slot milling cutter is then used to cut the headspace to the desired dimensions. Similar procedure is followed for cutting a dovetail slot , but a dovetail slot cutter is used in place of T-slot cutter.

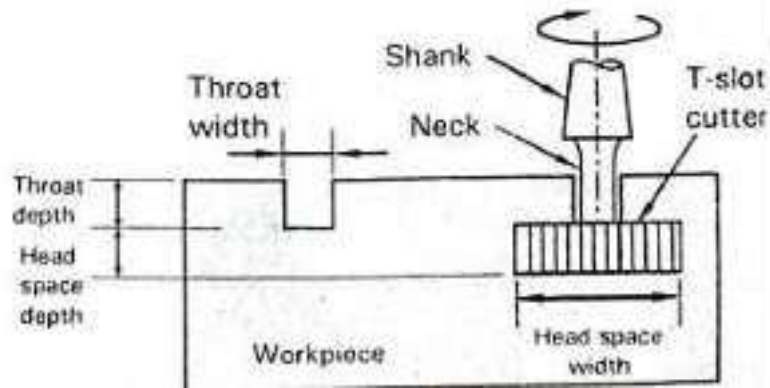

Fig.4 Slot milling

e) Angular milling

Angular milling or angle milling is a machining process for producing all types of angular cuts like V-notches and grooves, serrations and other angular surfaces. Refer figure 5. The cutter, called angle milling cutter or angle cutter may be either single-angle type having teeth on its conical surface that can produce an angle or chamfer on the workpiece edge as shown in figure 5(a), or the cutter can be double-angle type having teeth on two conical surfaces that can produce double angle cuts as shown in figure 5(b). Angle cutters may also be used to produce dovetail slots in workpieces.

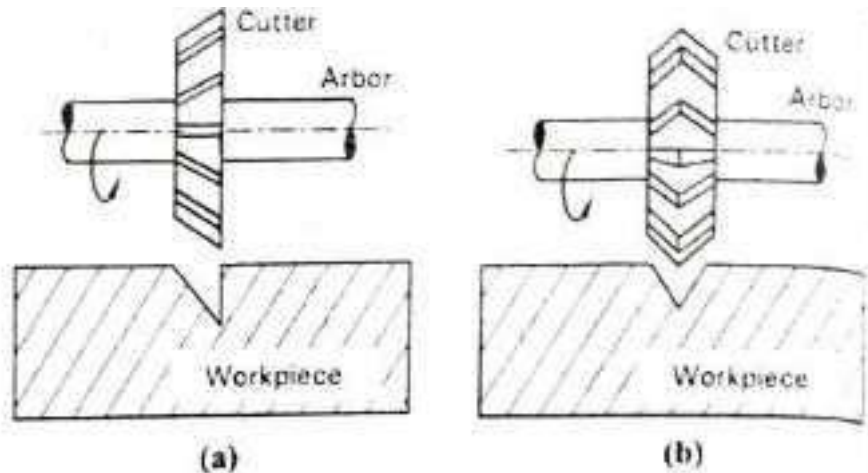

Fig.5 Slot milling

f) Form milling

Form milling is a machining process carried out for producing curved profiles with a variety of shapes like concave, convex, spline, etc., using cutters whose edge is shaped to produce a special

configuration on the surface of the workpiece Refer figure 6. The cutter known as form mill has teeth on its periphery and is designed in various shapes to suit the type of surface to be machined.

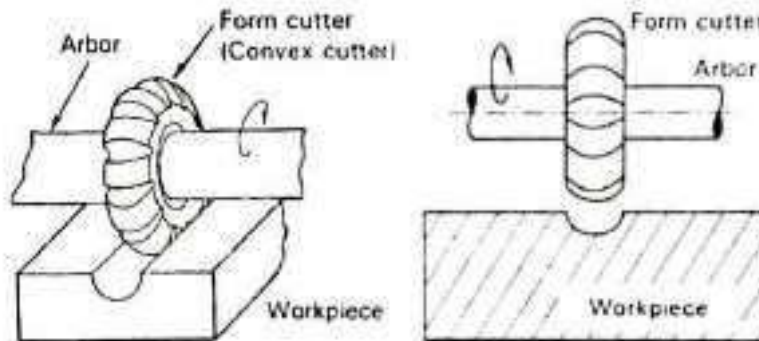

Fig.6 Slot milling

g) Straddle milling

Straddle milling is a machining process, in which a pair of side milling cutters is used for machining two parallel vertical surfaces simultaneously as shown in figure 7. The side milling cutter can have cutting edge on one or both sides as well as on the periphery.

Straddle milling is accomplished by mounting two side milling cutters on the same arbor, set apart at an exact spacing with the help of spacers, washers and shims, so that the distance between the cutting teeth of each cutter is exactly equal to the width of the workpiece area being machined.

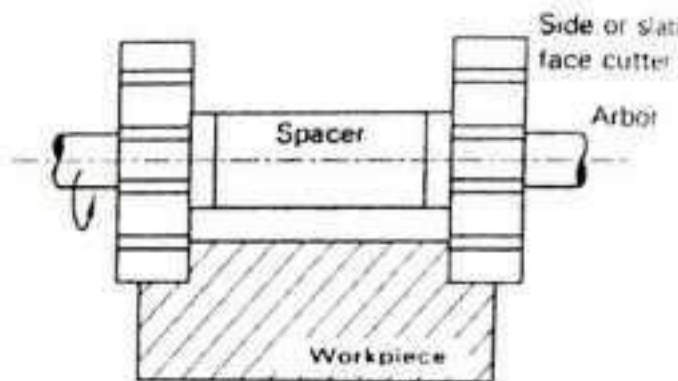

Fig.7 Slot milling

h) Gang milling

Gang milling is a machining process, in which two or more cutters are mounted on the same arbor, so that different profiles required on the workpiece can be machined simultaneously in a single pass as shown in figure 8. All the cutters used may be of the same type or of different types depending on the type of surface being machined.

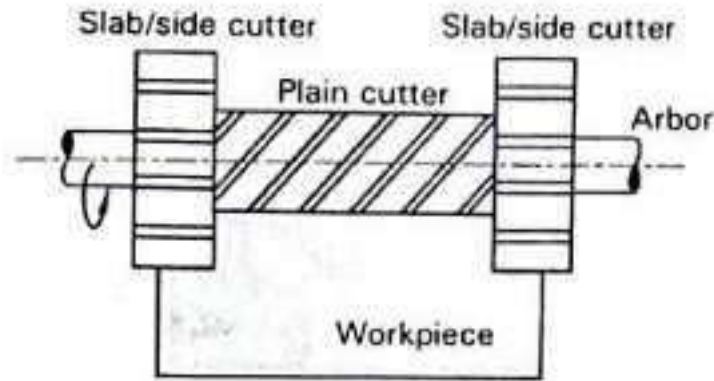

Fig.8 Gang milling

i) Gear cutting or Gear milling

Gear milling or gear cutting is a machining process carried out on a milling machine for cutting teeth of different shapes by using form milling cutters or involute gear cutters. The shape of the gear tooth profile depends on the shape of the cutter. Figure 9 shows the simplified diagram of a cutter in spur gear milling operation.

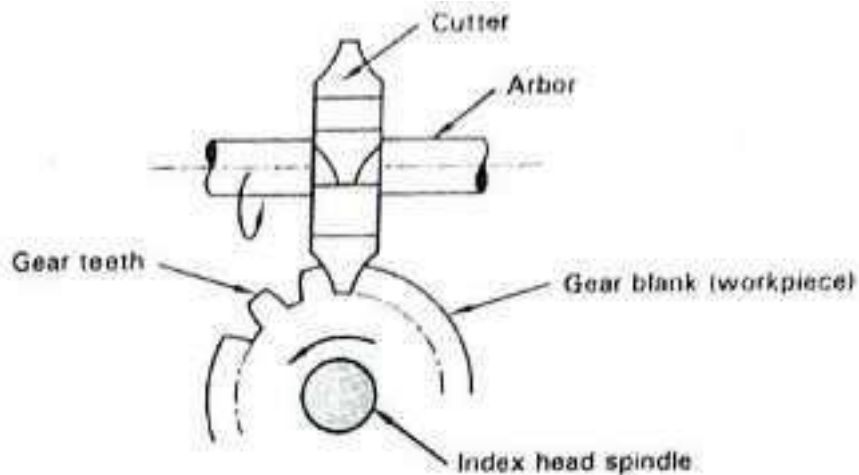

Fig.9 Gear cutting

The workpiece is mounted rigidly on the index head spindle with the cutter touching the periphery of the workpiece. The vertical dial is then set to zero reading. The cutter is chosen according to the module and number of teeth to be cut. The cutter is mounted on the arbor of the horizontal milling

machine rotating at a suitable speed. The worktable is fed vertically upwards to impart depth of cut. Teeth are cut of the workpiece by feeding it linearly against the rotating cutter. Depth of cut is increased slowly until it reached the full depth of the tooth. After one tooth is cut, the workpiece is indexed(rotated) by a suitable mechanism for cutting the next teeth.

j) Thread milling

Thread milling or Tread milling is the operation carried out on milling to cut threads and worms by means of suitable cutters. Two types of cutters are generally used for producing threads. The first type of cutter, called single cutter consists of a single row of teeth mounted on the periphery of a cylinder as shown in figure 10(a). Such cutters are generally used for cutting threads having coarse pitch and on long screwed parts like lead-screws and worms. The second type of cutter consists of teeth in a number of rows, spaced from one another at a distance equal to the pitch as shown in figure 10(b). this type of cutter is used for producing threads for comparatively shorter lengths.

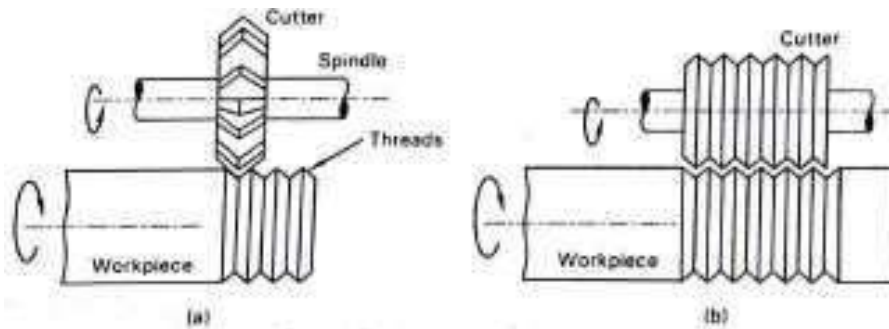

Fig.10 Thread milling

2.6 Indexing

- Milling operations sometimes require the rotation of work piece, correct to fractions of minutes, for each groove, slot, gear teeth, etc., to be cut evenly on the work surface.
- The accuracy of spacing between each cut becomes very important, and this is accomplished by means of a specialized attachment called indexing or dividing head. The process is referred as indexing.
- Indexing can be defined as the process of evenly dividing the circumference of a work piece into equally spaced divisions, in order to perform certain machining operations such as cutting gear teeth, splines, grooves in reamers and taps, etc. there are different types of indexing, however from the syllabus point of view, three types of indexing viz., simple indexing, compound indexing, and differential indexing are discussed herein.

2.7 Indexing mechanism

- A simple indexing mechanism as shown in figure (2.7). consists of a 40-tooth worm wheel fastened to the index head spindle, a single start threaded worm, a crank for turning the worm shaft and an index plate. Also, refer figure (2.10).
- The workpiece is secured to the index head spindle by means of a suitable holding device (not shown in figure).
- The goal of the indexing mechanism is to control the rotation of the index head spindle and hence the workpiece, so that the circumference of the workpiece can be divided into any desired number of equal divisions.
- The worm shaft carries the crank at its outer end, which in turn supports a spring loaded plunger as shown in the figure.
- The index pin (crank pin) works inside the plunger and can be adjusted to lock it into the desired hole circle on the index plate.
- By pulling the index pin outwards and rotating the plunger, the crank, and hence the worm shaft can be rotated.
- The index plate is also mounted on the same shaft (worm shaft) as the crank, but on a sleeve, in order to remain stationary while the crank and the worm shaft is being rotated.
- In operation, when the index pin (crank pin) is pulled outwards and the crank is rotated, the worm shaft rotates causing the worm to drive the worm wheel, and consequently the spindle head and the workpiece to turn.
- The distance or the angle through which the workpiece is rotated depends on the revolution given to the crank.

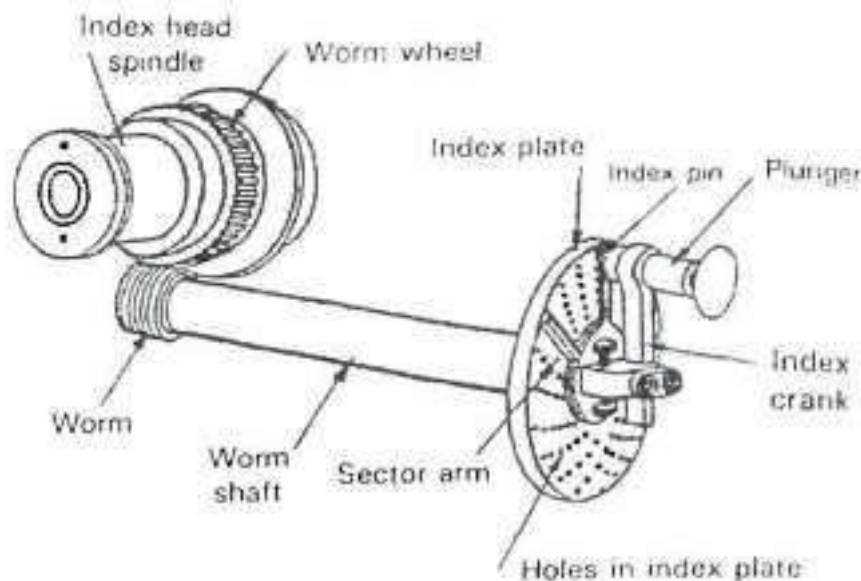

Fig. 2.7 Indexing mechanism

2.8 Use of Index Plate

- The index plate is a circular plate provided with a series of circles (six or more) of equally spaced holes.
- The index plate comes in three sets, each carrying different number of holes in them.
- The three standard plates of Brown and Sharp 1 type having different holes is given in table1. Figure 2.8 shows the index plate 1 of Brown and Sharp type.

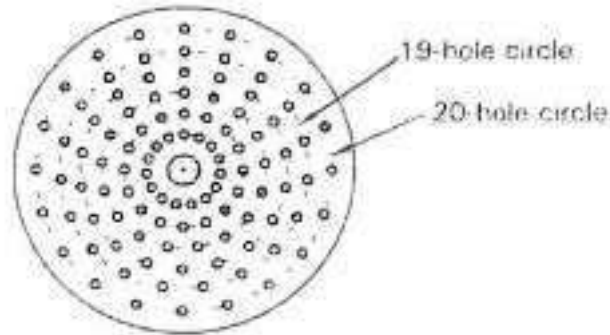

Fig. 2.8 Index plate 1 of Brown and Sharp type

Table 1. Index plates of Brown and[2]

Plate 1	15, 16, 17, 18, 19, 20 holes.
Plate 2	21, 23, 27, 29, 31, 33 holes.
Plate 3	37, 39, 41, 43, 47, 49 holes.

2.9 METHODS OF INDEXING

- There are different methods of dividing the circumference of a circular workpiece into equally spaced divisions.
- These include: Direct or Rapid indexing, Simple or Plain indexing, Compound indexing, Differential indexing and Angular indexing.
- From the syllabus point of view, the first three methods of indexing are discussed herein

2.10 SIMPLE OR PLAIN INDEXING

- In simple or plain indexing method, the workpiece is rotated by turning the crank as shown in figure 2.10. Also, refer figure 2.15.
- When the crank is rotated, the worm shaft rotates causing the worm to drive the work wheel and consequently the spindle to turn.

- As the spindle rotates, the workpiece that is secured to the spindle by means of a suitable holding device (not shown in figure) also rotates.
- The angle through which the workpiece rotates for each revolution of the crank depends on the velocity ratio between the work and the worm wheel.

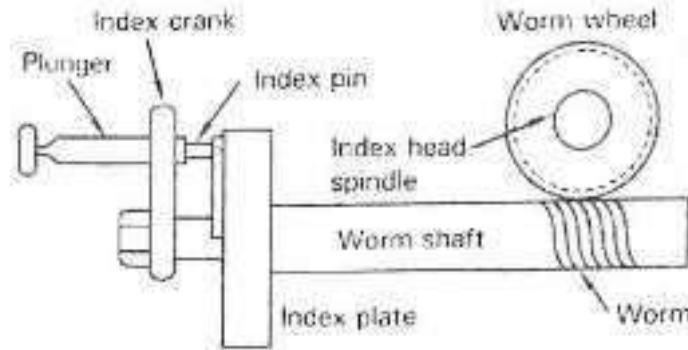

Fig. 10. Side view of the Indexing mechanism

To calculate velocity ratio

- Since the worm has a single start thread and the worm wheel 40 teeth, one revolution of the crank (i.e., of the worm) Causes the worm wheel to rotate through one pitch distance, i.e., equal to $1/40^{\text{th}}$ of a revolution.
- Similarly two turns of crank will make the workpiece to rotate through $2/40$ or $1/20^{\text{th}}$ of a revolution, and so on.
- In other words, 40 revolutions of the crank will make the workpiece to complete one full turn or a 360° revolution thereby making the ratio 40:1
- Therefore, one turn of the index crank $\frac{360^\circ}{40} = 9^\circ$
- Thus it is clear that, larger revolutions of the crank result in small rotation of the workpiece.
- Hence, we can divide the Circumference of the workpiece into any desired number of equal divisions.
- The following calculations shows the rotations required for the crank in order to divide the circumference of the workpiece into desired number of divisions.
 - For 2 divisions on the workpiece, the crank has to rotate $\frac{40}{2} = 20$ turns for each division
 - For 4 divisions on the workpiece, the crank has to rotate $\frac{40}{4} = 10$ turns for each division.

- Therefore, for N divisions on the workpiece, the crank has to be rotated $\frac{40}{N}$ for each division.
- In other words, the index crank movement is given by: Index crank movement = $\frac{40}{N}$ where, N = number of divisions required on the workpiece.

Numerical problems solved during class hours

2.11 COMPOUND INDEXING

- Compound indexing method is employed in those cases, when the number of divisions required on the workpiece cannot be obtained with simple or plain indexing method.
- This method involves two separate indexing movements that give the name compound indexing method. Compound indexing is performed in two stages:
 - [1]. The first movement is obtained by turning the index crank, a definite amount in one direction in the same way as in simple indexing, i.e., the crank pin is rotated through a required number of spaces in one of the hole-circles of the index plate, and then the crank pin is engaged with the plate. Refer figure 2.11(a).
 - [2]. The second index movement is obtained by turning the index plate along with the crank as shown in figure 2.11(b).

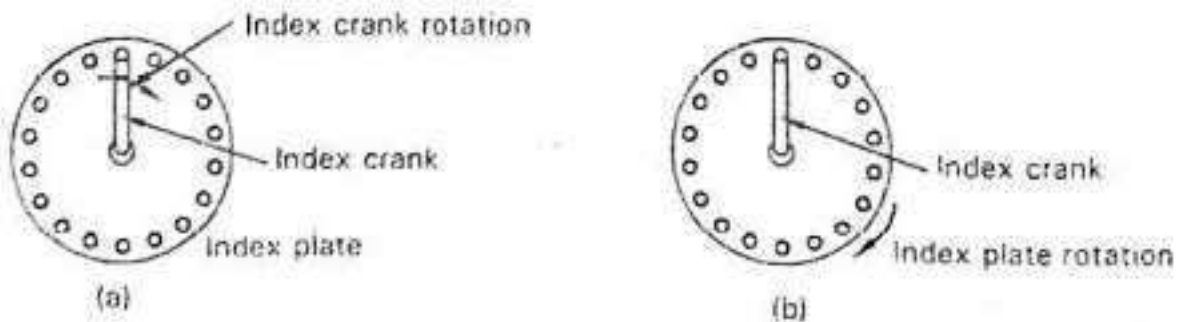

Fig 2.11 Movement of index crank in compound indexing

Turning of index plate

- Normally, the index plate is held stationary by a lock pin, which engages with one of the hole circles of the index plate from the back.
- While giving the second index movement, the lock pin at the back of the plate is removed and then the plate is rotated along with the index crank, either in the same direction or in the reverse direction through the calculated number of spaces of another hole-circle.
- The lock pin is engaged with the hole-circle at the back of the plate.
- The second movement is finally added or subtracted from that obtained in the first index movement

Rule for compound indexing

Where,

$$= 1 \pm 2$$

The rule for compound indexing is given by the formula ⁴⁰

- N = Number of divisions required on the workpiece
- $\frac{1}{N}$ = The hole-circle used by the crank pin
- $\frac{1}{N}$ = The hole-circle used by the lock pin

=

- $\frac{1}{N}$ = The hole spaces moved by the crank pin in $\frac{1}{N}$ hole circle, and the crank pin in $\frac{1}{N}$ hole- circle.

Numerical problems solved during class hours

2.12 DIFFERENTIAL INDEXING

- Differential indexing is similar to the compound indexing, wherein, the required division of the periphery of the job is obtained by the combination of two movements:
 - a) The movement of the index crank through the required number of spaces in one of the hole circle of the index plate as in the case of simple indexing, and,
 - b) The simultaneous movement of the index plate along with the crank, either in the same direction or reverse direction, thus adding (gain) further movement to, or subtracting (lost) from that obtained in the first movement.
- The only difference between compound and differential indexing is that the movement of the index plate is accomplished by moving the plate by means of a train of gears connecting the index head spindle to the worm shaft. Refer figure 2.12

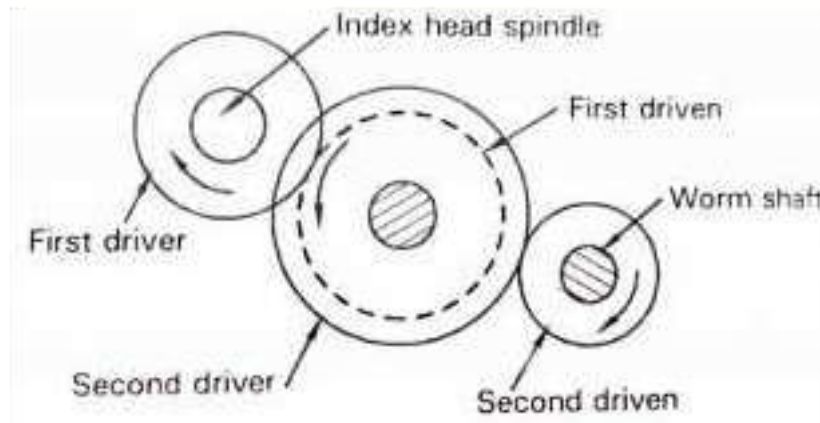

Fig. 2.12 Compound gear train

- As in compound indexing, the index plate locking-pin should be taken out to make the index plate free to rotate.
- The dividing head in differential indexing is supplied with change gears as follows: 24, 24, 28, 32, 40, 44, 48, 56, 64, 72, 86, 100
- With these change gears and three sets of Brown and sharp Index head spindle plates, it is possible to index any number from 1 to 382 divisions.
- Differential method of indexing is employed when the number of divisions cannot be obtained by simple indexing.
- Both simple and compound gear train arrangements are used in differential indexing.
- In these gear trains, the first driver is always mounted on the spindle head, i.e., the spindle on which is mounted the worm wheel and the workpiece. Figure 2.12 shows the compound gear train arrangement for differential indexing.

Numerical problems on Differential Indexing solved during class hours

2.13 DRILLING

- Drilling is a machining operation of producing a cylindrical hole in a solid workpiece by means of a revolving tool called drill bit.
- The tool is also called twist drill since it has sharp twisted edges formed around a cylindrical body. Figure 2.13 shows the drilling operation.
- In operation, the drill bit is held rigidly in the chuck of the machine and rotated by the spindle at high speeds.

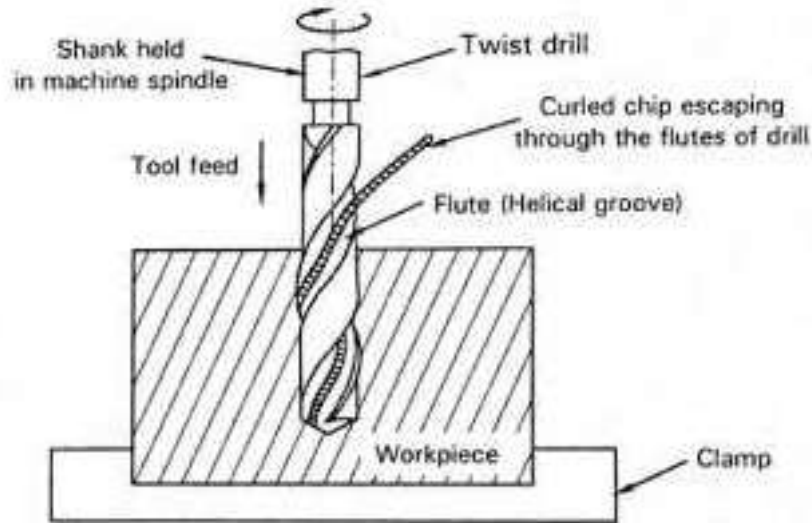

Fig. 2.13 Compound gear train

- With the help of a hand wheel or by automatic means, the drill bit is forced to move against the rigidly clamped workpiece.
- A hole is generated by the sharp cutting edges of the rotating drill bit and meanwhile, the excess material removed (chips) gets curled and escapes through the helical grooves provided in the drill bit.
- Although drilling seems to be a simple process, it is actually a complex one. The tool apart from performing the cutting action also extrudes the cut material (chips) from the workpiece.
- Since the cutting action takes place inside the workpiece, a lot of heat generated is minimized by circulating a suitable coolant.

2.13.1 DRILLING MACHINE OPERATIONS:

A number of operations that can be performed on a drilling machine using the various tools are as follows:

- a) Drilling
- b) Boring
- c) Reaming
- d) Counter-boring
- e) Counter-sinking
- f) Spot facing
- g) Tapping

a) Drilling

- Drilling is defined as the metal removal process carried out by forcing a rotating drill bit against rigidly clamped solid work-piece to get a cylindrical hole.

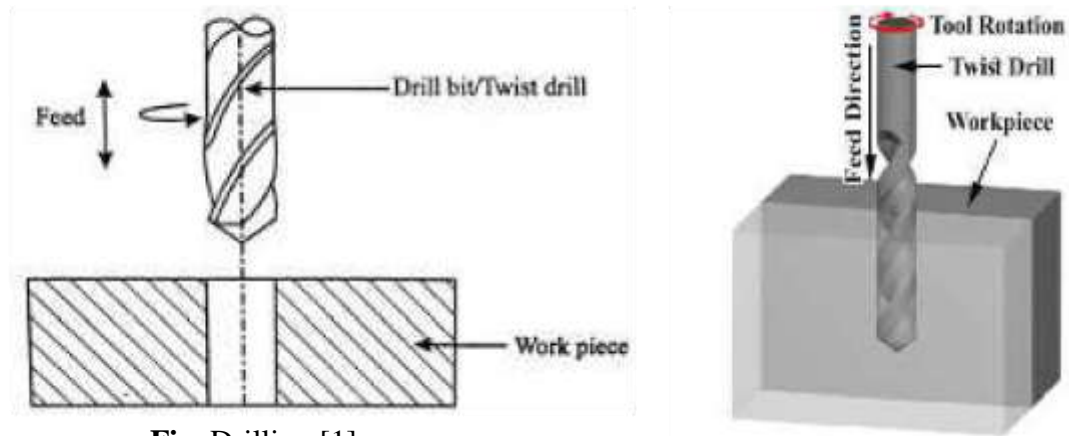

Fig. Drilling [1]

- A typical drilling operation is shown in figure. Drilling is carried out by a rotating cutting tool to make circular holes in solid materials. The tool which makes the hole is called as twist drill, since it has a sharp twisted edge formed around a cylindrical tool provided with a helical groove along its length to allow the cut material to escape through it.
- The sharp edges of the conical surfaces ground at the lower end of the rotating twist drill cuts the material by peeling it circularly layer by layer when forced against a work-piece. The removed material chips get curled and escapes through the helical groove provided in the drill. A liquid coolant is generally used while drilling to remove the heat of friction and obtain a better finish for the hole.

b) Boring

- Boring is a machining process carried out for enlarging a previously drilled hole by means of an adjustable cutting tool having only one cutting edge. shown figure below.
- Boring is usually performed when a drill bit of the required dimension is not available.
- In such cases, a hole is first drilled to the nearest dimension and then a single point cutting tool is fastened and adjusted to a boring bar to enlarge the size of the existing hole to the required dimension.
- While boring, the tool is rotated at speeds slower than that of reaming. In addition to enlarging a previously drilled hole, boring operation corrects the hole location and out-of-roundness, if any, as the tool can be adjusted to remove Previously drilled hole more metal from one side of the hole than the other.

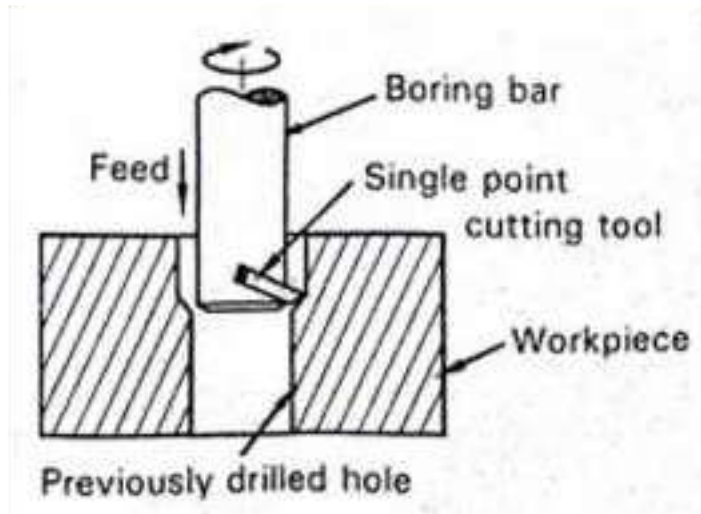

Fig. Boring

c) Reaming

- Reaming is a machining process carried out for finishing a previously drilled hole so as to bring it to a more exact size and to improve the surface finish of the hole. Refer figure below.
- The operation is carried out using a multi-tooth revolving tool called reamer, which consists of a set of parallel straight or helical cutting edges along the length of the cylindrical body.
- While reaming, the speed of the spindle is reduced to nearly half of that of the drilling. The material is removed in small amounts, and hence the surface of the drilled hole is finished with high accuracy.

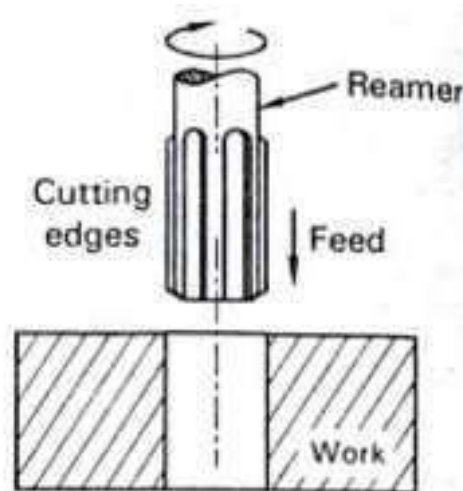

Fig. Reaming

d) Counter-boring

- Counter-boring is to increase the size of a hole at one end only through a small depth.

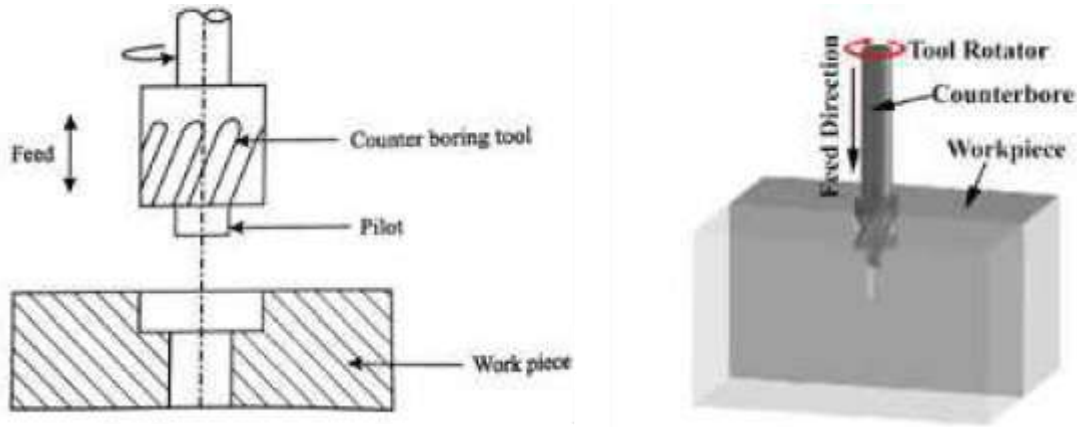

Fig. Counter-boring

- The counter-boring forms a larger sized recess or a shoulder to the existing hole.
- The cutting tool will have a small cylindrical projection known as pilot to guide the tool while counter-boring.
- The diameter of the pilot will always be equal to the diameter of the previously drilled hole. Interchangeable pilots of different diameters are also used for counterboring holes of different diameters.
- The speeds for counter-boring must be two-thirds of the drilling speed the corresponding size of the drilled hole.
- Generally, the counterboring is done on the holes to accommodate the socket head screws, or grooved nuts, or round head bolts.

e) Countersinking

- Countersinking is the operation of making the end of a hole into a conical shape. It is done using a countersinking tool shown in figure.

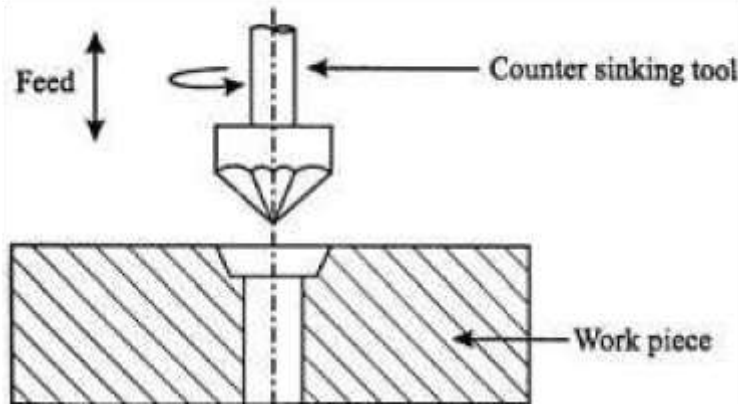
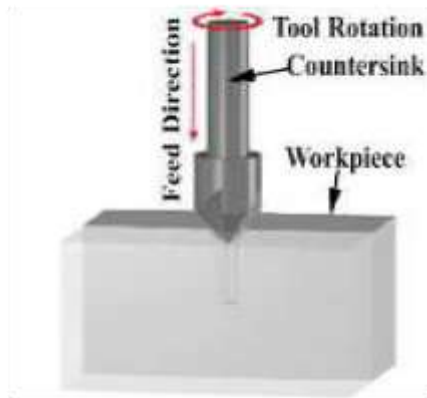

Fig. Countersinking



- The countersinking process may also be employed for deburring the holes. The cutting speeds for countersinking must be about one-half of that used for similar size drill.
- The countersunk holes are used when the countersunk screws are to be screwed into the holes so that their top faces have to be in flush with the top surface of the work-piece.

f) Spot Facing

- Spot facing is a finishing operation to produce a flat round surface usually around a drilled hole, to give a good bearing surface for the proper seating of a bolt head or a nut.
- The spot that is faced may be a circular raised pad on a casting or merely the surface around a bolt hole. Spot facing may be done with a counter-boring tool shown or using a special spot facing tool shown in Fig.

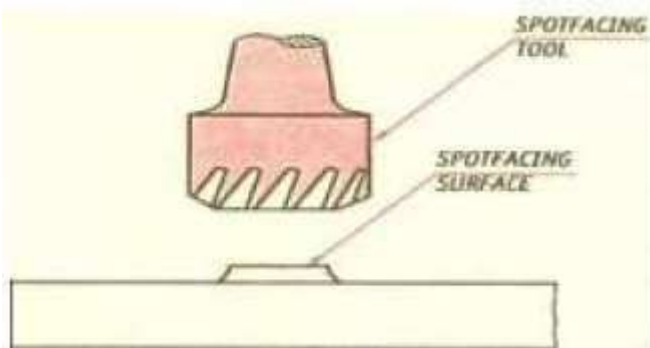

Fig. Spot facing



g) Tapping

- The tapping is the process of cutting internal threads with a thread cutting tool called tap.

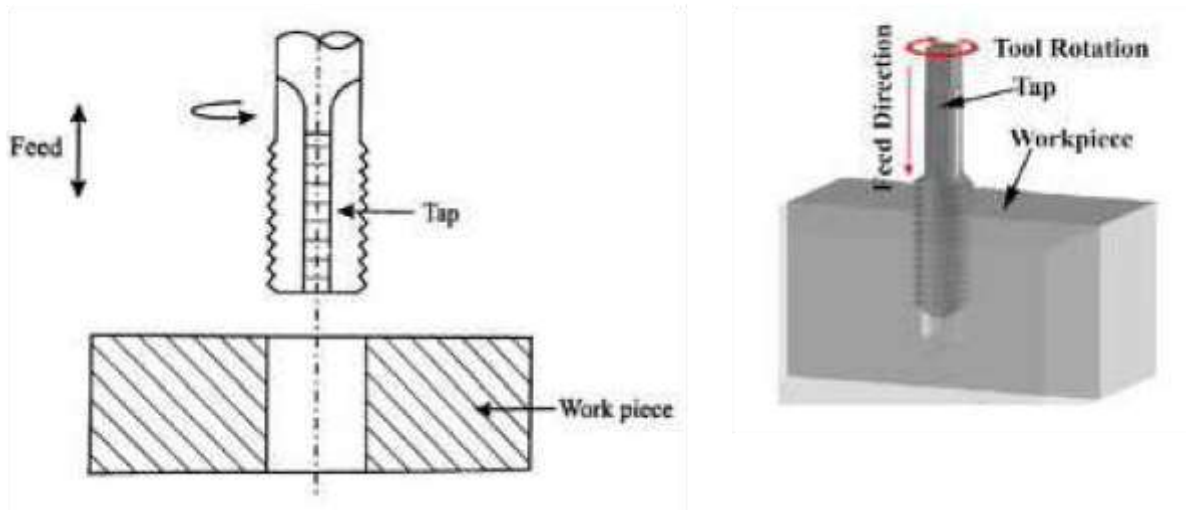

Fig. Tapping

- A tap is a fluted threaded tool used for cutting internal threads. Before tapping, a hole which is slightly smaller than the size of the tap is drilled.
- For cutting the threads, the tap is fitted in the tapping attachment which in turn is mounted in the drilling machine spindle, and the threads are cut in the same way as drilling.
- While tapping in a drilling machine the spindle has to rotate at very slow speeds. The tap will be held in a collapsible type of tapping chuck, which is inserted in the spindle of the drilling machine. Generally tapping is done on a drilling machine when identical threading is required on large number of parts.

2.14 CLASSIFICATION OF DRILLING MACHINES

- Drilling machines are classified according to their general construction and type of work they are required different to do. The types of drilling machines include:
 - a) Portable drilling machine
 - b) Bench or Sensitive drilling machine
 - c) Radial drilling machine
 - Plain radial drilling machine
 - Universal radial drilling machine
 - Semi-universal radial drilling machine
 - d) Upright drilling machine
 - Round column or Pillar drilling machine
 - Box column upright drilling machine
 - e) Multi-spindle drilling machine
 - f) Gang drilling machine
 - g) Automatic drilling machine
 - h) Deep hole drilling machine
 - i) Computer Numerical Control (CNC) drilling machine.

2.14.1 Bench (Sensitive) Drilling Machine

- Bench drilling machines are used for drilling small holes at high speeds in small sized work pieces. The diameter of the hole usually ranges from 1.5 mm to 15 mm.
- The machine is usually supported on a work-bench and hence the name bench drilling machine. Figure 2.14 shows the details of a bench drilling machine. The machine consists of the following parts;

a) Base

- The base of the machine is made from cast iron material and supports the vertical column.
- The base is provided with holes to secure it firmly to the table or bench with the help of bolts shaft v-belt Stepped pulley and nuts.

b) Vertical column

- The column is a hollow steel pipe mounted rigidly on the base. It supports the drill head & worktable.

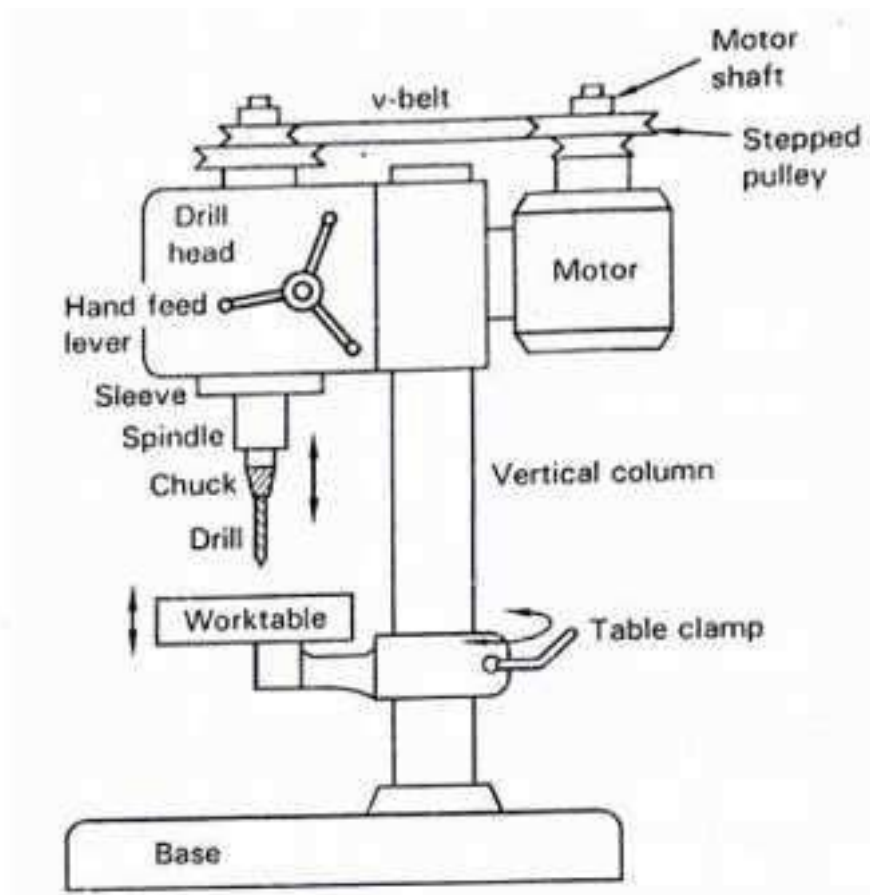

Fig. Bench or sensitive drilling machine

c) Worktable

- The worktable supports the work piece to be drilled.
- The table can be raised or lowered and can be clamped to the vertical column at any desired position.
- This helps to accommodate different sizes of workpiece on the table. The table can also be swiveled around the vertical column to any desired position, if need.

d) Drill head

- A fixed drill head located at the top end of the vertical column carries an electric motor and a mechanism through which the spindle can be made to rotate, as well as slide up and down.
- The top end of the spindle is connected to a stepped cone pulley which obtains power (rotary motion) from the motor shaft through a v-belt arrangement.
- The speed of the spindle can be varied by changing the belt position on the cone pulley. The lower end of the spindle carries a socket/drill chuck to hold the drill bit rigidly during operation. The vertical movement of the spindle and hence the drill bit, is controlled by the hand feed lever.

2.14.1.1 Specification of Bench (Sensitive) Drilling Machine

Bench or sensitive drilling machine is specified by one or more of the following criteria.

- Maximum diameter of the work that can be drilled.
- Power of motor
- Spindle speed and feed
- Weight of the machine, etc.

2.14.2 Radial Drilling Machine

- Radial drilling machines are used for drilling medium or large diameter holes of up to 50 mm in heavy work pieces. Figure shows the principal parts of a radial drilling machine. The machine consists of the following parts:

a) Base

- The base of the machine is a large cast iron material on which is mounted a cylindrical vertical column.
- The base is provided with T-slots, which help the workpiece to be clamped rigidly to the base of the machine.

b) Vertical column

- The column is a long, cylindrical shaped part fastened rigidly to the base.
- The column carries a radial arm that can be raised or lowered by means of an electric motor and can be clamped to any desired position. The radial arm can also be rotated (swiveled) in a complete circle around the column.

- (A drill chuck holds the cutting tool of any size, whereas a socket is used to hold a tool of a particular shank size.)

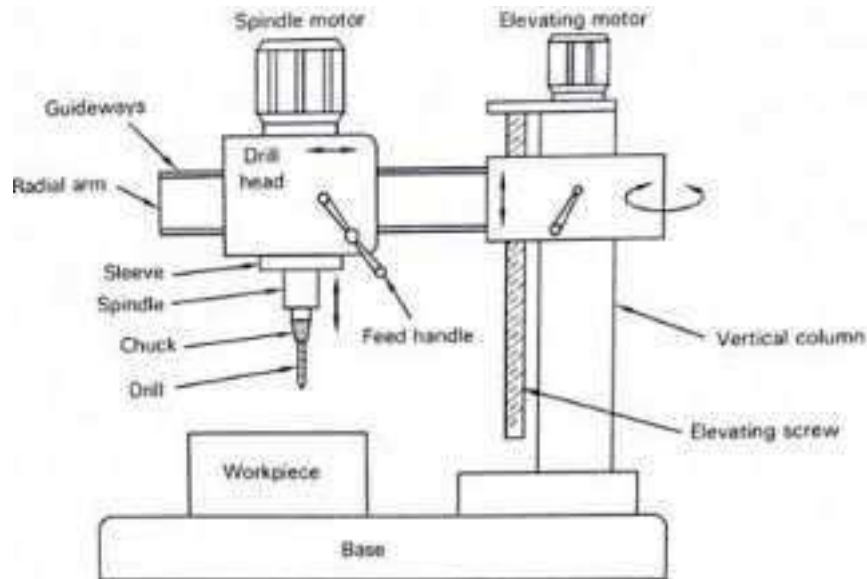

Fig. Radial drilling machine

c) Drill head

- The drill head is mounted on the radial arm and carries a driving motor and a mechanism for revolving and feeding (power feed) the drill bit into the work piece.
- The drill head can be moved horizontally on the guideways provided in the radial arm, and can be clamped to any desired position.
- With the combination of the movements of radial arm and the drill head, it is possible to move the drill bit and hence generate a hole at any desired position without moving the work piece.

2.14.2.1 Specification of Radial Drilling Machine

Radial drilling machine is specified by one or more of the following criteria.

- Length of arm
- Diameter of column
- Range of spindle speed and feed
- Motor power
- Drilling depth
- Weight of the machine, etc.

2.14.3 Upright Drilling

- Machine Upright drilling machines are used for drilling holes of up to 50 mm diameters in medium sized work pieces.

- The machine is similar in design to that of sensitive drilling machine, but differs specifically in its weight, rigidity, power mechanism feeding and a wide range of spindle speeds and feeds.
- Based on the design of vertical column, upright drilling machines classified into two types:
 - ✓ Round column or Pillar drilling machine
 - ✓ Box column upright drilling machine
- of the two types listed above, Pillar or Round column type is the most details of the machine are described commonly used in industries. The constructional in brief as follows:

2.14.3.1 Round Column Upright Drilling Machine or Pillar Drilling Machine

- Below Figure shows the details of the round column details of the machine are discussed in brief as upright drilling machine or pillar drilling machine. The constructional follows
- The machine consists of a round vertical column, referred as pilar, mounted on a strong and a rigid base which rests on the floor ne vertical column carries a power head at the top and a table arm, which supports the work table.
- The table arm can be raised or lowered on the vertical column with the help of a rack and a pinion arrangement.
- This movement facilitates for accommodating workpieces of different height. The table arm can also be swiveled or rotated in an arc up to 180° around ne Vertical column and can be clamped at any desired position.
- Large work pieces that cannot be mounted on the worktable may be supported directly on the base. In such cases, the table arm is swung aside, and the workpiece is mounted on the base of the machine.
- Apart from the two movements of the table arm, there is another adjustment given to the worktable which is supported on the table arm.
- The round worktable may be rotated about its own axis by 360°. This movement permits drilling of holes on pitch circles. Pillar drilling machine allows the operator to hand feed or power feed the tool into the work piece.
- The power feed mechanism automatically advances the tool into the workpiece. The power head carries a gear drive mechanism with which the spindle speeds and feeds can be varied for carrying out drilling in different types of work pieces.

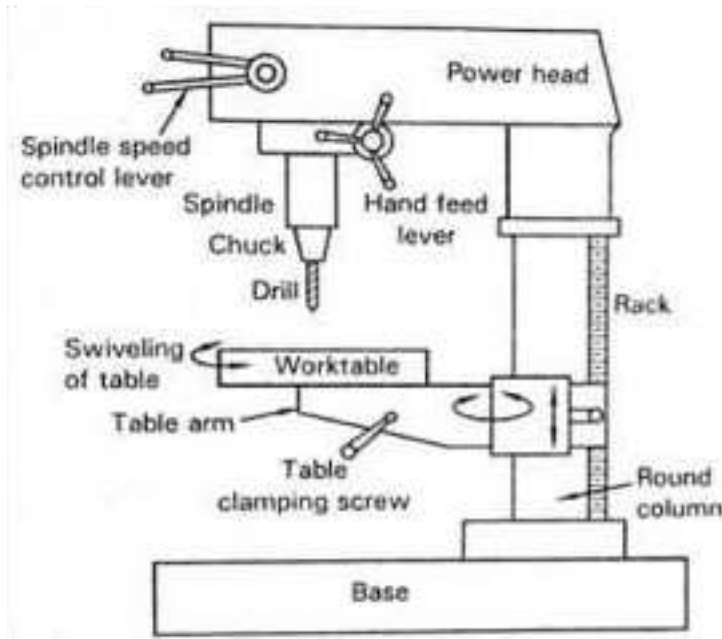

Fig. Pillar drilling machine

2.14.3.1 Specification of Round Column Upright Drilling Machine

Bench or sensitive drilling machine is specified by one or more of the following criteria.

- Maximum diameter of the work that can be drilled.
- Power of motor
- Spindle speed and feed
- Weight of the machine, etc.

2.14.4 MULTIPLE SPINDLE DRILLING MACHINE

- Below Figure shows the simplified diagram of a multiple spindle drilling machine.
- The constructional details of the machine are discussed in brief as follows: Multiple spindle drilling machines, as the name suggests, have several spindles driven by a single power head, and all the spindles holding the drill bits are fed into the workpiece simultaneously.
- The spindles are so constructed that their centre distance can be adjusted in any position within the drill head depending on the job requirement.
- For this purpose, the drill spindles are connected to the main drive by means of universal joints.
- The spindles in a multiple spindle drilling machine may carry drill bits of similar sizes or different sizes depending on the diameter of the holes to be drilled.
- Either the spindles move downwards, or the worktable is designed to move upwards to obtain the required feed (depth of cut).

- Most of the machines are designed with worktable moving upwards along the guideways of the column.
- The spindle heads can also carry different tools for performing different operations on the work piece. For instance, the first spindle head may be used to drill a hole, the second head for reaming and the third head for performing tapping operation.
- The machine is designed to hold as many as 50 spindles operated by a common drive and are mostly used in mass production applications.

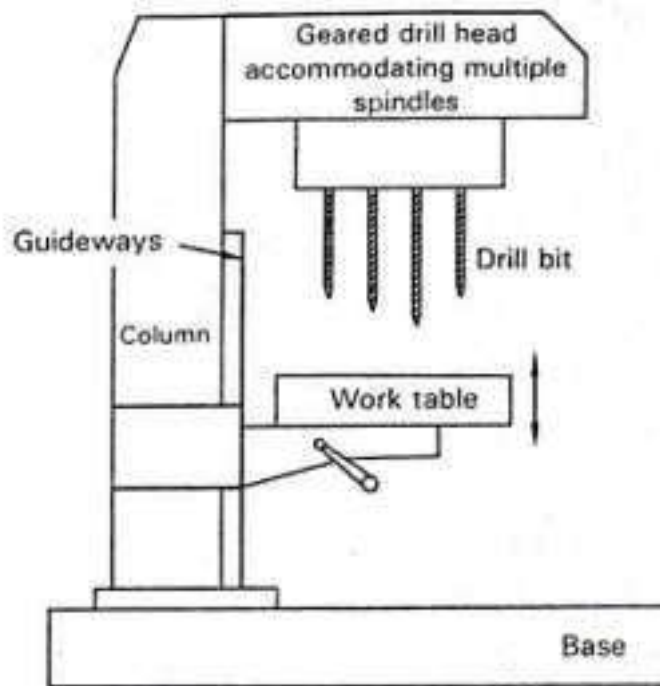

Fig. Multiple spindle drilling machine

2.14.5 GANG DRILLING

- Gang drilling machine is used when several related operations such as drilling, reaming, counterboring etc., are to be performed in succession on a single workpiece. Figure shows the block diagram of a three-spindle gang drilling machine.
- The constructional details of the machine are discussed in brief as follows. The machine consists of independent columns, heads and spindles mounted rigidly on a common base.
- The spindles can be driven by power or manually by hand and can be independently or collectively set for the desired speed and depth.
- The machine carries a single worktable on which the work piece can be slid into position for the operation at each spindle. table may be of stationary type or adjustable type.

- Gang drilling machines are designed with drill spindles permanently spaced, or in some machines the position of the columns may be adjusted, so that the space between the spindles may be varied.
- Gang drilling machines are used in mass production applications, wherein a single operator or more than one operator may be employed to perform various operations.

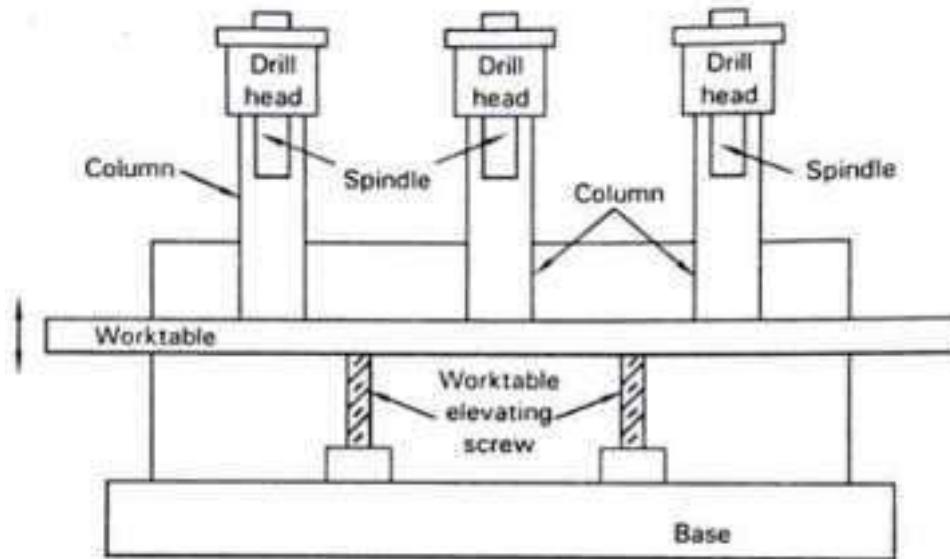

Fig. Gang drilling machine

2.14.5.1 Specification of Gang Drilling Machine

Gang drilling machine is specified by one or more of the following criteria.

- Number of drill head/ spindles
- Distance between spindles
- Maximum distance from spindle nose to table
- Working surface
- Overall size of the machine, etc.

2.15 BORING MACHINE

- Boring machine is used to enlarge a previously drilled hole to the correct size, especially in large and heavy parts like pumps, turbines, railroad wheels, etc., by means of a single point cutting tool.
- The operation performed is referred a boring. Besides enlarging holes, a boring machine can also be used to perform operations like drilling, facing, milling, etc.

Classification of Boring Machine Boring machines are broadly classified as follows:

- 1) Horizontal boring machine

- Table type
 - Planer type
 - Floor type
 - Multiple head type
- 2) Vertical boring machine
 - Single column type
 - Double column type
 - 3) Jig boring machine (Precision boring machine)
 - 4) Diamond (Fine) boring machine
 - 5) CNC boring machine, etc.

2.15.1 Table Type Horizontal Boring Machine

Below Figure shows the table or universal type horizontal boring machine. The machine consists of the following parts.

a) Vertical main column

- The main column is rigidly mounted on the bed of the machine and vertical supports the headstock unit.
- The column carries a guideway along which the headstock travels up and down. The column is usually made hollow in order to accommodate the counterweights which balance the headstock and make it easier to move.

b) Headstock

- The headstock carries the horizontal spindle assembly, electric motor, and a number of different units and mechanisms in to it, support, drive, and feed the screw and can be boring tool.
- The headstock can be moved vertically on the column by means of elevating clamped at any desired position.

c) Horizontal spindle

- The horizontal boring spindle suitably housed in the headstock, is hollow, its end carrying a tapered hole in order to receive the shanks of cutting tools.
- The spindle rotates between two precision roller bearings and can be fed axially either forward or backward according to the requirements.

d) Worktable and Saddle

- The machine consists of a saddle and a rotary worktable.
- The bottom face of the saddle fits in the horizontal guideways provided on the bed, thereby allowing it to be moved longitudinally along the bed, while the upper face of the saddle is

provided with guideways to accommodate the worktable which can be moved at right angles to the longitudinal motion. The movement of the saddle & the worktable can be done either manually or by power as desired.

e) Bed

- The bed is a heavy cast iron structure supporting all the parts of the machine. The bed houses in it, various mechanisms for vertical movement of headstock and the longitudinal traverse of the worktable, apart from various toolings over it.

f) End support column

- The end column is designed to support one end of the long and heavy boring tool during operation.
- The column is provided with vertical guideways along which the bar holder travels up and down.

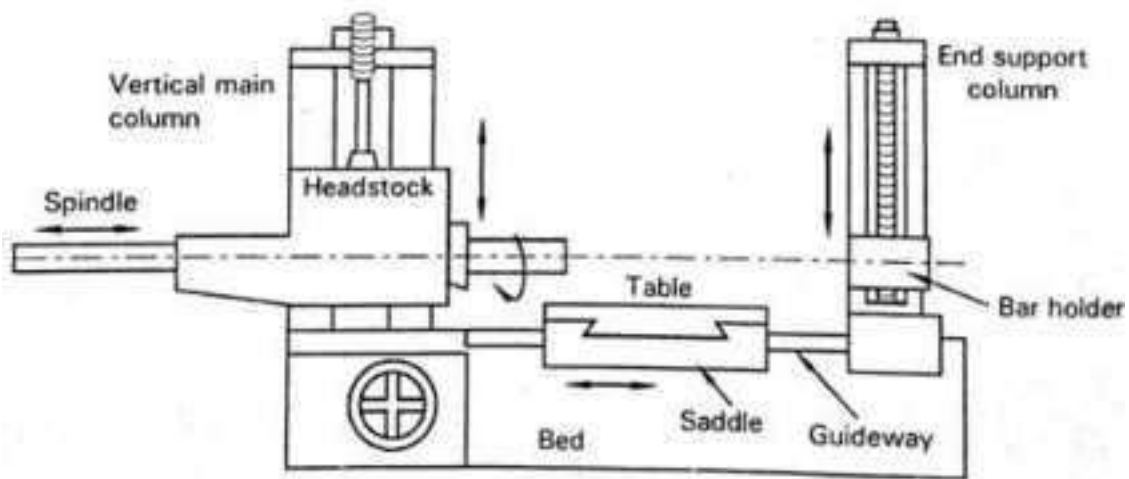

Fig. Table Type Horizontal Boring Machine

2.15.1.1 Specification of Horizontal Boring Machine

Horizontal boring machine is specified by one or more of the following criteria.

- Spindle diameter
- Spindle travel
- Motor capacity and range of spindle speeds
- Worktable dimensions
- Height of spindle axis from table surface

- Longitudinal worktable traverse, and
- Cross-movement of worktable

2.15.2 Double Column or Standard Vertical Boring Machine

- Below Figure illustrates the double column type of vertical boring machine in its simplest form. This type of machine is used for machining the inside, outside, and the face of symmetrical parts.
- The machine consists of the following parts:

a) Vertical columns

- The machine consists of two vertical columns, one on each side of the bed.
- The columns are bridged together by means of a cross-rail. The column is usually made hollow in order to accommodate different mechanisms for transmitting power to the cross-rail, work table, etc.

b) Cross-rail

- The cross-rail is a horizontal member connecting the two vertical columns of the machine.
- It carries spindle head/s (tool head/s) and can slide up and down on the vertical guideways of the two columns by means of elevating screws and can be clamped to any desired position.
- The cross-rail is provided with guideways at its front for the tool head/s to move towards left or right end of the machine.
- The tool head is designed for being swiveled to a certain angle for taking angular cuts.

c) Worktable

- The worktable is mounted on the bed of the machine and rotates about its vertical axis.
- The workpiece is fastened to the revolving table, while the cutting tools which are stationary, advance vertically into the revolving workpiece.

d) Bed

- The bed is a rigid structure, usually cylindrical in shape and together with the columns forming a single casting.
- The bed supports the worktable and houses in it, various mechanisms for rotation of the worktable to take place.

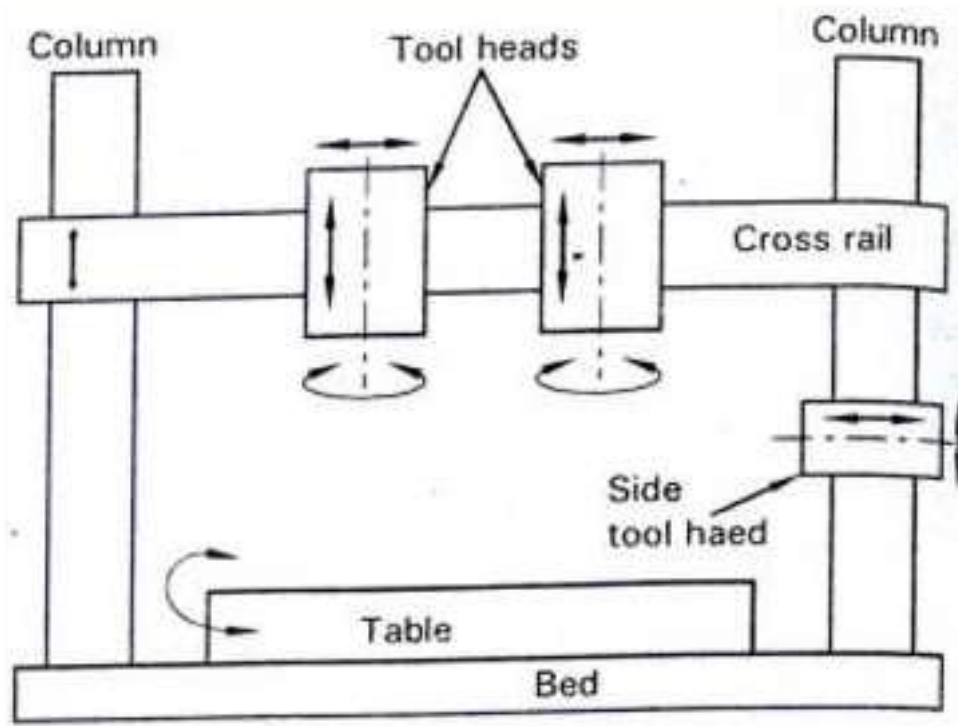

Fig. Double Column or Standard Vertical Boring Machine

{**Note:** Some machines are designed either with single or two tool heads on the cross-rail, and also a side tool head that can travel up and down on the guideways of the column. However, all the tool heads cannot be operated at the same time. The machine is designed based on the requirements.}

2.15.2.1 Specification of Vertical Boring Machine

Vertical boring machine is specified by one or more of the following criteria.

- Maximum turning diameter of work
- Worktable diameter
- Speed range of worktable
- Maximum weight of work that can be accommodated on worktable
- Maximum working height of workpiece

2.16 SHAPING MACHINE

- Shaping is a machining process of removing the excess material from the workpiece by means of a single-point cutting tool held in a reciprocating ram.
- The process is employed to produce flat surfaces (horizontal, vertical, or inclined), grooves, T slots, dovetails, and may also be used to produce contoured surfaces with the use of copying attachments.
- The machine used for performing the operation is called shaping machine or shaper. Figure shows the principle of operation on a shaping machine.
- In operation, the workpiece is clamped rigidly on the machine table, and a single-point cutting tool is held in the tool post mounted on the ram of the shaping machine.
- The ram reciprocates the tool to and fro across the workpiece as shown in figure (a). Hence, the ram makes two strokes during the cutting process. These two strokes are called cutting stroke and return stroke as shown in figure (b) and (c).

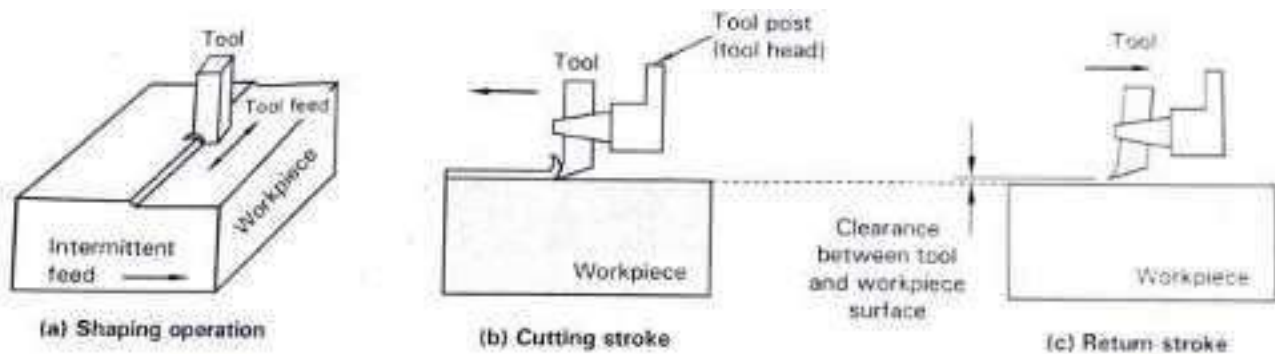

Fig. Principle of shaping

- During cutting stroke, the tool moves in the forward direction, during which it cuts a small thin strip of metal from the workpiece as shown in figure (b).
 - No cutting of material takes place during the return stroke* of the ram and hence, this stroke is also called idle stroke.
 - During return stroke, the tool is lifted clear of the workpiece, reducing the cutting action to one direction only. Refer figure (c).
 - The workpiece is given an indexed feed (equal amount after each cut) in a direction perpendicular to the line of action of the cutting tool.
 - Shaping is a relatively simple process used often in the tool room, or for machining one or two pieces for prototype work. Tooling is simple, and the machine does not always require operator attention while cutting.
- (*In draw-cut type of shaping machine, cutting operation takes place during the return stroke of the ram.)

Classification of Shaping Machine (Shaper)

Shapers may be classified according to:

- a) Design of work table
 - Standard shaper
 - Universal shaper
- b) Driving mechanism
 - Crank shaper
 - Geared shaper
 - Hydraulic shaper
- c) Design of travel of ram
 - Horizontal shaper
 - Vertical shaper
 - Traveling head shaper
- d) Nature of cutting stroke
 - Push cut shaper
 - Draw cut (pull type) shaper

2.16.1 Constructional Features of Horizontal Shaper

Below Figure shows the principal parts of a horizontal shaper. It consists of the following parts:

- a) **Base**
 - The base is a heavy cast iron body that supports the entire weight of the machine parts, and also the forces generated during the machining process.
 - The base is secured rigidly to the floor with the help of foundation bolts and nuts.
- b) **Column**
 - The column is a rigid hollow casting mounted on the base.
 - It houses the driving motor, control devices, and the mechanism for driving the ram & the worktable.
 - The column carries horizontal guideways at its top on which the ram reciprocates, and vertical guideways at its front face on which the cross-rail slides.
- c) **Cross-rail**
 - The cross-rail mounted on the front vertical guideways of the column can be raised up and down by means of an elevating screw to accommodate workpiece of different heights,
 - The cross-rail is provided on its front face with horizontal guideways, which is perpendicular to the ram movement.

d) Worktable

- The worktable is a box shaped casting that can slide on the horizontal and vertical guideways of the cross-rail.
- The front face of the table is supported by an adjustable table support to withstand the weight of the workpiece and the cutting action during operation.

e) Ram

- The ram is a rigidly braced casting, and of semi-cylindrical form located on the top of the column.
- The ram reciprocates on the guideways provided on top of the column by means of a slotted link mechanism. The cutting tool is attached to the ram via a tool holder and head.

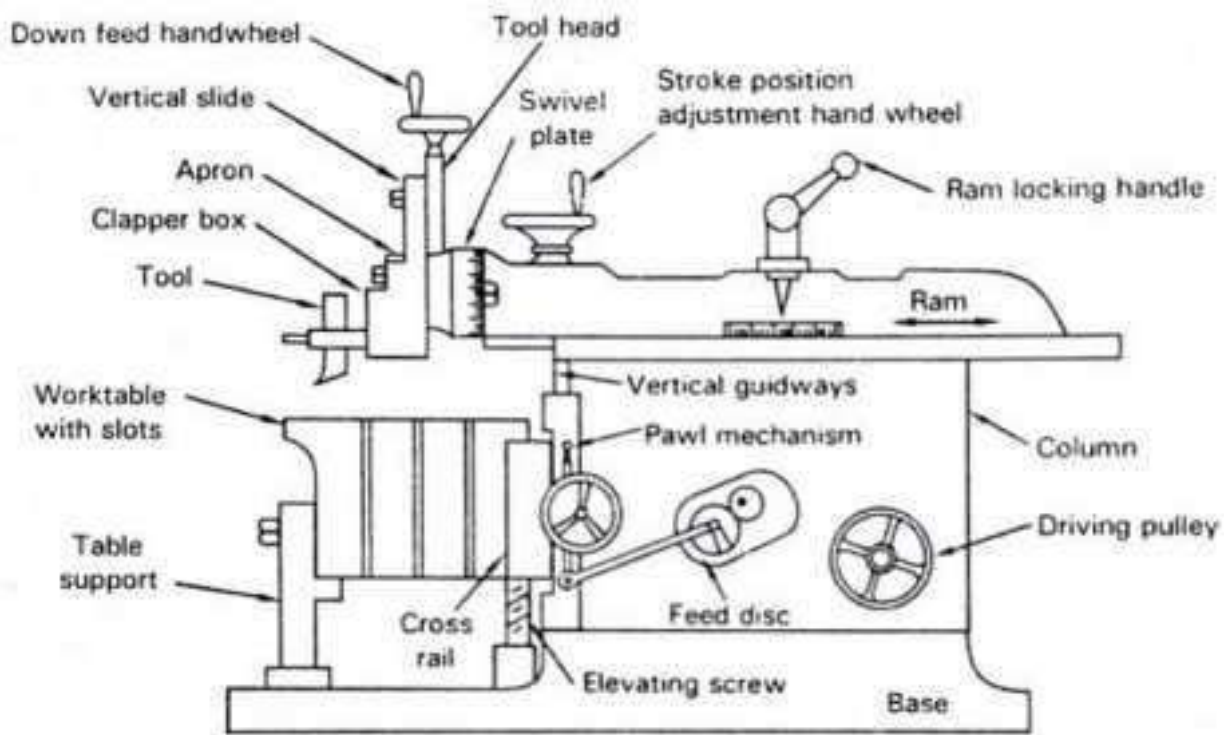

Fig. Horizontal shaper machine

f) Tool head

- The tool head mounted at the front end of the ram, holds the tool and imparts the tool, the necessary vertical and angular feed movements.
- Vertical movement of tool that provides the depth of cut is achieved by moving the vertical slide downwards by means of tool feed handle, and angular movement for machining angular surfaces is achieved by unbolting and tilting the swivel plate to the desired angle.
- The apron carries the clapper box. which allows the cutting tool to be lifted upwards* during the return stroke of the ram, thereby preventing the scratching of the tool on the job.

(*Cutting action takes place when the ram moves in the forward direction only. When the ram moves in the backward direction the tool is lifted slightly upwards by means of clapper box in order to prevent cutting action.)

COMPUTER NUMERICAL CONTROL (CNC)

Introduction

Numerical Control (NC)

- The machine is operated automatically by **the means of directly inserted coded numerical instructions.**
- NC is a concept of automated machine control.
- It is a **programmable automation of machine tool.**
- Manufacturing process is **controlled by numbers, letters and symbols.**

Definition of Computer Numerical Control (CNC): “Computer Numerical Control or CNC is an advanced form of the NC system where the machine control unit is a dedicated **microcomputer instead of a hard-wired controller, as in conventional NC.**”

OR

“Computer numerical control (CNC) is a method for **automating control of machine tools through the use of software embedded in a microcomputer attached to the tool.** It is commonly used in manufacturing for machining metal parts.”

CNC Technology has powered the Machine Tool industry today. **It is used in majority of machine tools like machining centers, turning centers, grinders, lathes, drilling machines, etc.**

Computer Numerical Control has evolved during the rapid improvements of the computer technology. The advent of Microprocessors from the 1970s have helped in quick advancements in the Computer Technology and is in turn adapted in modern CNC Technology.

Today's CNC Controller has latest features like high speeds of operation, large memories, bus architectures, improved servos, etc.

CNC Technology has powered the Machine Tool industry today. It is used in majority of machine tools like machining centers, turning centers, grinders, lathes, drilling machines, etc.

COMPONENT OF A CNC SYSTEM

A CNC System consists of the following elements:

1. Input Device
2. MCU or Machine Control Unit
3. Machine Tool

4. Driving System
5. Feedback devices
6. Display Unit

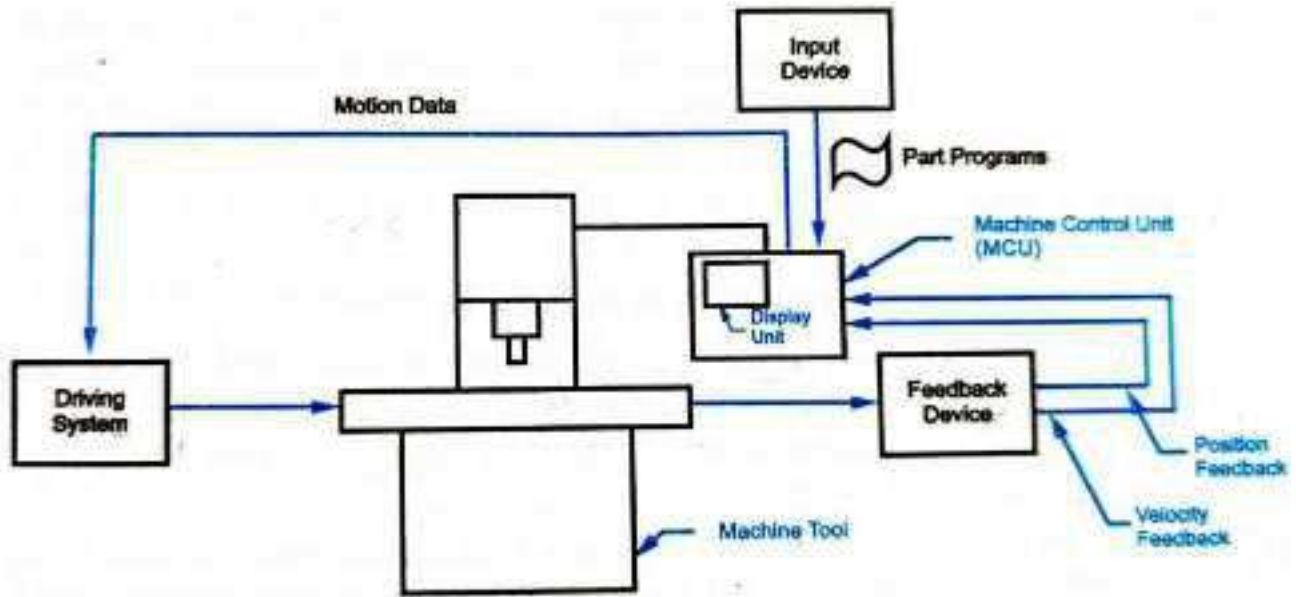

Fig. Elements of a CNC system

1. INPUT DEVICE:

The part program is entered into the CNC Control or the MCU through the input device. There is various input devices used on a CNC Machine such as

- a) **USB (Universal Serial Bus) Flash drive:** Here the USB flash drives transfer data to the control. USB is very common nowadays and its use is increased in modern computers.
- b) **Serial Communication:** A serial communication port connects a computer system and a CNC Machine tool through an interface called RS-232. Most machines have RS-232 port and an RS-232 cable connects the computer and the CNC Machine to transfer data from the computer to the CNC Machine.
- c) **Ethernet Communication:** The Ethernet communication is a more reliable and efficient means of transferring part programs from Computer to the CNC Control.
- d) **Conversational Programming:** This is another way to input part programs to the controller through a keyboard. Built-in intelligent software inside the controller enables the operator to enter step by step data.

2. MCU OR MACHINE CONTROL UNIT:

The Machine Control Unit or the MCU is the heart of the CNC System. It consists of the following components:

- a) **Central Processing Unit:** The CPU is the brain of the MCU and it comprises of
- i). **a control section** that retrieves data from the memory and generates signals which in turn activates all MCU components.
 - ii). **An ALU (Arithmetic Logic Unit)** that performs integer arithmetic operations like addition, subtraction, multiplication, counting, etc and logical operations
 - iii). **Immediate Access Store or Immediate Access Memory:** This holds the data and programs temporarily that is required at that instant by the control section.
- b) **CNC Memory:** The memory of the CNC is divided into
- i). **Main Memory** which consists of Read Only Memory (ROM) and Random Access Memory (RAM). The ROM stores the Operating System Software and machine interface programs. The RAM stores the Part programs.
 - ii). **Secondary Memory** such as Hard disks which is used to store large programs and which can be used by the main memory when required.
- c) **Input/output Interface:**
- The Input/output interface or the I/O interface establishes communication between the machine operator, the components of the CNC system and other connected computers.
 - The Operator control panel is the interface through which the machine operator communicates with the CNC system. A keyboard and a display screen are also included in the panel.
- d) **Machine tool controls:**
- A Machine Tool consists of various axes such as X, Y, Z, A, B, C and a spindle which rotates at the designed RPM.
 - The position and velocity control of each of the axis and the rotational speed control are accomplished by certain hardware components in the MCU.
 - The MCU generates control signals that are transformed into a form suitable for the specific position control systems that is required to drive the various axes of the machine.
- e) **Sequence controls for auxiliary functions:**
- Apart from the general functions like spindle speed, feed rate, etc, certain auxiliary functions like tool emergency stop, tool changing function, etc are carried out under part control program controls.

3. MACHINE TOOL:

- This can be any type of machine tool such as a Machining center, a turning center, a lathe, milling machine, etc.
- The essential parts of the machine tool include the machine table, machine slide, the driving lead screw, ball screw, rigid and heavy machine Structure, and automatic tool changing system, spindle and spindle drive system, chip removal System etc.
- The machine table is controlled in the X and Y axes, while the spindle runs along the Z axis.
- In other machine tools, there are additional axes such as A, B or C that allows rotary motions around the X, Y and Z axes.

4 DRIVING SYSTEM:

- A drive system essentially is made up of amplifier circuits, drive motors, and ball lead-screws. The control signals (position and speed) of each axis are fed by the Machine Control Unit (MCU) to the amplifier circuits.
- Then, the control signals are augmented to actuate drive motors which in turn rotate the ball lead-screws to position the machine table.
- The commonly used types of electrical motors include DC Servo Motor, AC Servo Motor, Stepping Motor and Linear Motor.

5. FEEDBACK DEVICES:

- For the accurate operation of a CNC Machine, the positional values and speed of the axes needs to be continuously updated.
- This is done by the feedback devices.

6. DISPLAY UNIT:

- The display unit is the device that ensures interaction between the machine operator and the machine.
- Display unit displays the current status of operation such as the spindle RPM, the running part program, the feed rate, position of the machine slide, etc.

Advantages of CNC machines

1. The accuracy and repeatability obtained is high.
2. Complex shaped contours can be machined.
3. Can be easily programmed to handle variety of product styles.
4. High volume of production compared to conventional machines
5. Even lesser skilled or trained people can operate CNC Machines unlike the

Conventional ones where highly skilled people are required.

6. CNC Machines can be used uninterruptedly without turning them off provided regular maintenance is done.
7. Prototypes can be produced faster and thus results in reduced lead times.
8. Avoids errors that were otherwise committed by humans operating conventional machines.
9. Since CNC machines can be programmed, one person may well take care of a number of CNC Machines. This reduces the employees and hence costs are reduced.
10. Using CNC Machines results in a safer work environment since the operator is not exposed to the machine area during machining.
11. CNC Machines can be upgraded to newer technologies by replacing the existing CNC Control with an advanced one.
12. Many CNC Machines can be linked together to a main 'computer. Programs from the main computer can be downloaded to any connected CNC Machine. This leads us to another type of NC concept called as the Direct Numerical Control (DNC).

Disadvantages of CNC machines

1. A thorough programming knowledge is required by the operators or programmers. This again requires skilled programmer and hence the cost of labour can be high.
2. Cost of a CNC Machine is high compared to the Conventional Machine Tools.
3. The spares of CNC Machines are relatively costlier than Conventional Machines.
4. CNC Machines require air conditioned environment and/or a chiller unit. Thus extra costs are involved.

Applications of CNC machines

1. **Signage. : Whether you're creating a small-scale 2D project or a more complex 3D signage component, a CNC machine can get the job done quickly and cleanly. CNC routers are capable of skillfully working with a wide range of materials, including foam, wood, plastic, acrylic, aluminum, brass, and more.**
2. **Cabinets and furniture.:** Cabinet manufacturing is one of the most common applications for CNC machines, whether used to create customized or more standard pieces. In addition to cabinetry, CNCs help shops produce closet sets, Shaker and Raised Panel Doors, countertops, chairs, tables, and more with immense precision and unrivaled efficiency.
3. **Aluminum and brass machining.:** Working with non-ferrous metals like aluminum and brass requires increased cutting capability from your CNC machine – in addition to a little more attention and preparation.
4. **Prototyping and 3D modeling. :** Precise modeling and prototyping are essential to the success of the production process.

5. **Musical instruments.:** The precision capabilities of CNC machines are perhaps never more crucial than when creating musical instruments. Every component needs to be cut to exact specifications and made to interact properly in order to produce a beautiful range of sounds.
6. **Some Industries where CNC Machining are used**
 - a) Industries for removing metal
 - b) Industries for Fabricating Metals
 - c) Electrical Discharge Machining (EDM) Industry
 - d) Other Industries where CNC machines are used: CNC machines are also used extensively in the wood working industries to perform various operations like routing (similar to milling) and drilling. CNC technology is also used in number of lettering and engraving systems. There are also CNC machines for the electrical industry such as CNC coil winders, and CNC terminal location and soldering machines.

CNC MACHINING CENTERS AND TURNING CENTERS

- Several of our application examples of single station manufacturing cells consisted of CNC machining centers.
- The machining center, developed in the late 1950s before the advent of CNC, is a machine tool capable of performing multiple machining operations on a work part in one setup under NC program control.
- Today's machining centers are CNC. Typical cutting operations performed on a machining center use a rotating cutting tool, such as milling, drilling, reaming, and tapping.
- Machining centers are classified as vertical, horizontal, or universal. The designation refers to the orientation of the machine spindle.
- A vertical machining center has its spindle on a vertical axis relative to the worktable, and a horizontal machining center has its spindle on a horizontal axis.

TYPES OF CNC MACHINES

There are many different types of CNC machines, but the most common types are

- CNC lathes,
- CNC milling machines,
- CNC drilling machines, and
- CNC machine centers.

CNC LATHES

- ❑ CNC lathes are used to create cylindrical parts. The workpiece is held in a chuck and rotated, while the cutting tool is moved in and out to remove material.
- ❑ CNC lathes can be used to create a wide variety of parts, including shafts, bearings, and gears.

CNC MILLING MACHINES

- ❑ CNC milling machines are used to create flat and complex parts. The workpiece is held in a fixture and the cutting tool is moved in three axes to remove material.
- ❑ CNC milling machines can be used to create a wide variety of parts, including molds, dies, and prototypes.

CNC DRILLING MACHINES

- ❑ CNC drilling machines are used to create holes in parts. The workpiece is held in a fixture and the drill is moved in three axes to create the hole.
- ❑ CNC drilling machines can be used to create a wide variety of holes, including round, square, and hexagonal holes.

CNC machine centers are a combination of CNC lathes and CNC milling machines. CNC machine centers can be used to create a wide variety of complex parts, including parts with both cylindrical and flat features.

CNC MACHINING CENTERS AND TURNING CENTERS

- ❑ CNC machine centers are a combination of CNC lathes and CNC milling machines. CNC machine centers can be used to create a wide variety of complex parts, including parts with both cylindrical and flat features.
- ❑ Several of our application examples of single station manufacturing cells consisted of CNC machining centers.
- ❑ The machining center, developed in the late 1950s before the advent of CNC, is a machine tool capable of performing multiple machining operations on a work part in one setup under NC program control.
- ❑ Today's machining centers are CNC. Typical cutting operations performed on a machining center use a rotating cutting tool, such as milling, drilling, reaming, and tapping.
- ❑ Machining centers are classified as vertical, horizontal, or universal. The designation refers to the orientation of the machine spindle.
- ❑ A vertical machining center has its spindle on a vertical axis relative to the worktable, and a horizontal machining center has its spindle on a horizontal axis.

CNC MACHINING CENTERS

These are usually designed with features to reduce non-productive time. These features include the following:

- **Automatic tool-changer.** A variety of machining operations means that a variety of cutting tools is required. The tools are contained in a tool storage unit that is integrated with the machine tool. When a cutter needs to be changed, the tool drum rotates to the proper position, and an automatic tool changer (ATC), operating under part program control, exchanges the tool in the spindle for the tool in the tool storage unit. Capacities of the tool storage unit commonly range from 16 to 80 cutting tools.
- **Automatic work part positioned.** Many horizontal and universal machining centers have the capability to orient the work part relative to the spindle. This is accomplished by means of a rotary table on which the work part is fixture. The table can be oriented at any angle about a vertical axis to permit the cutting tool to access almost the entire surface of the part in a single setup.
- **Automatic pallet changer.** Machining centers are often equipped with two or more separate pallets that can be presented to the cutting tool using an automatic pallet changer while machining is being performed with one pallet in position at the machine; the other pallet is in a safe location away from the spindle. In this safe location, the operator can unload the finished part from the prior cycle and then fixture the raw work part for the next cycle.

CNC TURNING CENTER

- This is capable of performing various turning and related operations, contour turning, and automatic tool indexing, all under computer control.
- In addition, the most sophisticated turning centers can accomplish
 - 1) Work part gaging (checking key dimensions after machining),
 - 2) Tool monitoring (sensing when the tools are worn),
 - 3) Automatic tool changing when tools become worn, and
 - 4) Automatic workpart changing at the completion of the work cycle.

Another development in NC machine tool technology is the **mill-turn center**, which has the general configuration of a turning center, but also the capability to position a cylindrical work part at a specified angle so that a rotating cutter can machine features into the outside surface of the part.

Here are some of the benefits of using CNC machines:

Accuracy: CNC machines can produce parts with very high accuracy. This is important for many applications, such as aerospace and medical.

Repeatability: CNC machines can produce parts that are identical to each other. This is important for mass production.

Efficiency: CNC machines can produce parts much faster than manual machining. This can save time and money.

Flexibility: CNC machines can be used to produce a wide variety of parts. This makes them a versatile tool for many different industries.

REFERENCES:

1. Shaw, M C, (2014), Metal Cutting Principles, Oxford University Press.
2. McGeough, J A, (1988), Advanced Methods of Machining, Springer.
3. Boothroyd, G., and Knight, W. A., Fundamentals of Machining and Machine Tools, CRC Press.
4. Chattopadhyay, A B, (2013), Machining and Machine Tools, Wiley India.
5. Mikell P. Groover, (2019), Fundamentals of Modern Manufacturing: Materials, Processes, and Systems, Wiley Publications.
6. Rao P. N., Manufacturing Technology II, Tata McGraw Hill.
7. **A text book of “Manufacturing Cutting & Forming” by Kestoor Praveen, Suggi Publishing**

B.Tech I Sem (Mech)-R17

COURSE OBJECTIVES:

- To introduce students to the basic concepts of Manufacturing via shaping, forming, machining and assembly. To develop a knowledge of appropriate parameters to be used for various machining operations.
- To make students aware of the necessity to manage manufacturing processes and systems for the best use of material and human resources with particular emphasis on product safety and environmental considerations.

UNIT – I

Metal cutting theory: Elements of cutting process – Geometry of single point tool and angles, chip formation and types of chips, built up edge and its effects- chip breakers. Mechanics of orthogonal cutting –Merchant's Force diagram, cutting forces – cutting speeds, feed, depth of cut, tool life, coolants, machinability.

UNIT – II

Lathe Machine: Principle of working, specification of lathe and types of lathes, operations of lathe and work holding and tool holding devices.CNC Machine Elements- Machine structure- Tooling for CNC Machines-Interchangeable tooling system and qualified tools, coolant fed tooling system, quick change tooling system, automatic head changers.

UNIT – III

Shaping, slotting and planning machines: -Principles of working – classifications, operations performed, machining time calculations. Drilling and Boring Machines – Principles of working, specifications, types, operations performed – tool holding devices – twist drill – Boring machines – Fine boring machines – Jig Boring machine. Deep hole drilling machine.

UNIT-IV

CNC Milling Machine: Principles of working – classifications of CNC milling machines– operations-milling cutters. Grinding machines–classifications–Different types of abrasives and bonds and selection of a grinding wheel.

UNIT – V:

Modern Machining Processes: Need for Nontraditional machining methods, Types-AJM,WJM,ECM,EDM,USM.Material Removal rate(MRR), Selections of tools and dielectric fluid, process variables .Plasma Machining and its applications, magnetic abrasive finishing. Applications, limitations and recent development.

COURSE OUTCOMES:

- To analyze various machining processes and calculate relevant quantities such as velocities, forces and powers.
- Identify and explain the function of the basic components of a machine tool.
- Understand the procedures and techniques involved for the manufacturing of components, and keep up to date with innovation through literature search.

- 1.Production Technology by R.K. Jain and S.C. Gupta, Khanna Publications
- 2.Production Technology by H.M.T. (Hindustan Machine Tools).hand book
- 3.Production Technology by P.C .Sharma, S Chand publication
4. Modern Machining Process / Pandey P.C. and Shah H.S./ TMH Publishers

REFERENCE BOOKS:

- 1.Machine Tools – C Elanchezhian and M. Vijayan, Anuradha Publications
- 2.Workshop Technology – B.S.Raghu Vamshi – Vol II, Dhanpatrai publications
- 3.Manufacturing Technology by P.N.Rao, Volume II, McGraw Hill
4. Advanced machining processes/ VK Jain/ Allied publishers.

UNIT NO	NAME OF THE UNIT	PAGE NO
I	Metal cutting theory	5-24
II	Lathe machine, CNC lathe	25-44
III	Slotting ,shpaing,planning	45-68
IV	Milling, CNC milling, grinding	69-111
V	Modern machining process.	112-125

COURSE COVERAGE

UNIT-1

SNO	TOPICS	NAME OF THE TEXT BOOK
1	Elements of cutting process, Geometry of single point tool and angles	Workshop Technology. VOL-2 – B.S.Raghu Vamshi
2	Chip breakers, types of chips, built up edge and effects.	Workshop Technology. VOL-2 – B.S.Raghu Vamshi
3	Merchants force diagram	Workshop Technology. VOL-2 – B.S.Raghu Vamshi
4	Cutting forces	Workshop Technology. VOL-2 – B.S.Raghu Vamshi
5	Coolants, tool life, machinability	Workshop Technology. VOL-2 – B.S.Raghu Vamshi

UNIT-2

SNO	TOPIC	NAME OF THE TEXT BOOK
1	Principle of working, specification of lathe and types of lathes.	Workshop Technology. VOL-2 – B.S.Raghu Vamshi
2	Latheoperations, workholdingdevices, toolholding devices.	Workshop Technology. VOL-2 – B.S.Raghu Vamshi
3	CNC machine elements, machine structure,	Workshop Technology. VOL-2 – B.S.Raghu Vamshi
4	Tooling for CNC machine, Interchangeable tooling system and qualified tools	Workshop Technology. VOL-2 – B.S.Raghu Vamshi
5	Coolant fed tooling system, quick change tooling system, automatic head changers.	Workshop Technology. VOL-2 – B.S.Raghu Vamshi

UNIT-3

SNO	TOPIC	NAME OF THE TEXT BOOK
1	Shaping,	Workshop Technology. VOL-2 – B.S.Raghu Vamshi
2	Slotting	Workshop Technology. VOL-2 – B.S.Raghu Vamshi
3	Planning	Workshop Technology. VOL-2 – B.S.Raghu Vamshi
4	Drilling	Workshop Technology. VOL-2 – B.S.Raghu Vamshi
5	Types of operation in drilling and deep hole drilling machine.	Workshop Technology. VOL-2 – B.S.Raghu Vamshi

UNIT-4

SNO	TOPIC	NAME OF THE TEXT BOOK
1	Milling, CNC milling introduction	Workshop Technology. VOL-2 – B.S.Raghu Vamshi
2	Milling operations, Types, Milling cutters.	Workshop Technology. VOL-2 – B.S.Raghu Vamshi
3	Grinding introduction, Types.	Workshop Technology. VOL-2 – B.S.Raghu Vamshi
4	Selection of the grinding wheel.	Workshop Technology. VOL-2 – B.S.Raghu Vamshi
5	Types of abrasives, bonds.	Workshop Technology. VOL-2 – B.S.Raghu Vamshi

UNIT-5

SNO	TOPIC	NAME OF THE TEXT BOOK
1	Need For Non Traditional Machining Process,	Workshop Technology. VOL-2 – B.S.Raghu Vamshi
2	Types Of Modern Machining Process	Workshop Technology. VOL-2 – B.S.Raghu Vamshi
3	AJM, WJM,EDM,ECM,USM	Workshop Technology. VOL-2 – B.S.Raghu Vamshi
4	Plasma machining,MRR.	Workshop Technology. VOL-2 – B.S.Raghu Vamshi
5	Procees variables, Selection of material	Workshop Technology. VOL-2 – B.S.Raghu Vamshi

UNIT-1**Metal cutting theory**

1. Economical manufacture of Machine parts ----- Growing competition.
2. Basic objectives of efficient and Economical machining practice.
 - a) Quick metal removal.
 - b) High class of surface finish.
 - c) Economy in tool cost.
 - d) Less power consumption.
 - e) Economy in the cost of replacement and sharpening tools.
 - f) Minimum idle time of machining tools.
3. Basic elements of machining.
 - a) Work piece b) Tool and c) Chip.

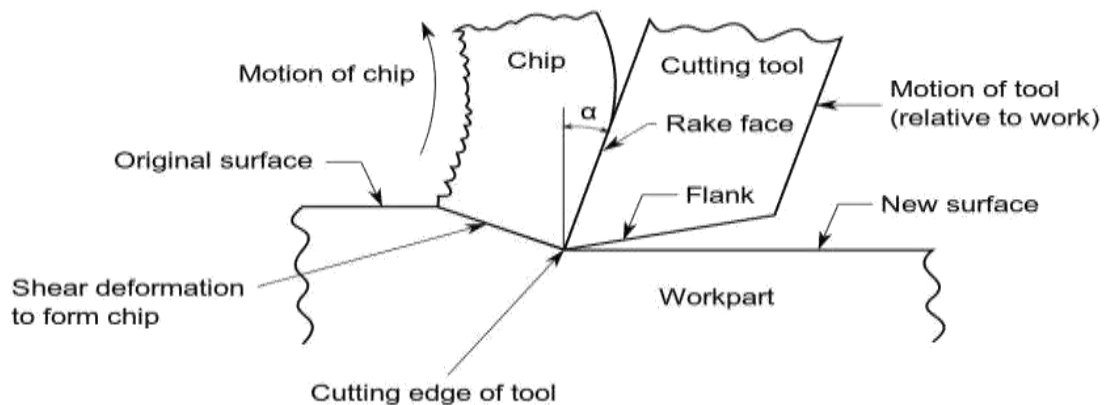

The relative motion between the tool and work piece is necessary for effecting the cutting action. The relative motion can be provided by both keeping the work piece stationary and moving the tool or by keeping the tool stationary and moving the work or by moving both in relation to one another.

The work piece provides the parent metal, from which unwanted metal is removed by cutting action of tool to obtain shape and size of the component. Chemical composition and physical properties of work piece material will have significant effect in machining.

The type and geometry of chip formed are greatly affected by the metal of work piece, geometry of cutting tool and method of cutting. Chemical composition and rate of flow of cutting fluid have considerable influence over the machining operation.

Orthogonal And Oblique Cutting:

The process of metal cutting is divided in to two main classes: Orthogonal and Oblique cutting. In Orthogonal cutting, cutting edge of tool remains normal to the direction of tool feed or work feed.

The direction of chip flow velocity is normal to the cutting edge of the tool.

The angle of inclination 'i' of the cutting edge of the tool with normal to the velocity v_c is zero.

The chip flow angle β i.e the angle between the direction of chip flow and normal to the cutting edge of the tool is zero. Cutting edge is longer than the width of the cut.

Oblique cutting:

The cutting edge of the tool always remains inclined at an acute angle to the direction of tool feed or work feed.

The direction of chip flow velocity is at an angle β with normal to the cutting edge of the tool. The angle is known as chip flow angle.

The cutting edge of the tool is inclined at an angle 'i' with the normal to the direction of tool feed or work feed.

Three mutually perpendicular components of the cutting forces act at the cutting edge of the tool. The cutting edge may or may not be longer than the width of cut.

Most of the metal cutting is carried out through oblique method.

Classification of Cutting Tools

Single point tools: Those having only one cutting edge. Ex. Lathe tools, Shaper tools, Planer tools, Boring tools etc.

Multi-Pont tools:- Those having more than one cutting edge. Ex. Milling cutters, Drills, Broachers, Grinding wheels.

Cutting Tools Can Also Be Classified According To The Motion As:

Linear motion tools: Lathe, Boring, Broaching, Planning and Shaping tools.

Rotary motion tools: Milling cutters, grinding wheels.

Linear And Rotary Tools: Drills, Honing Tools, Boring Heads Etc.

Geometry of Single Point Tools:

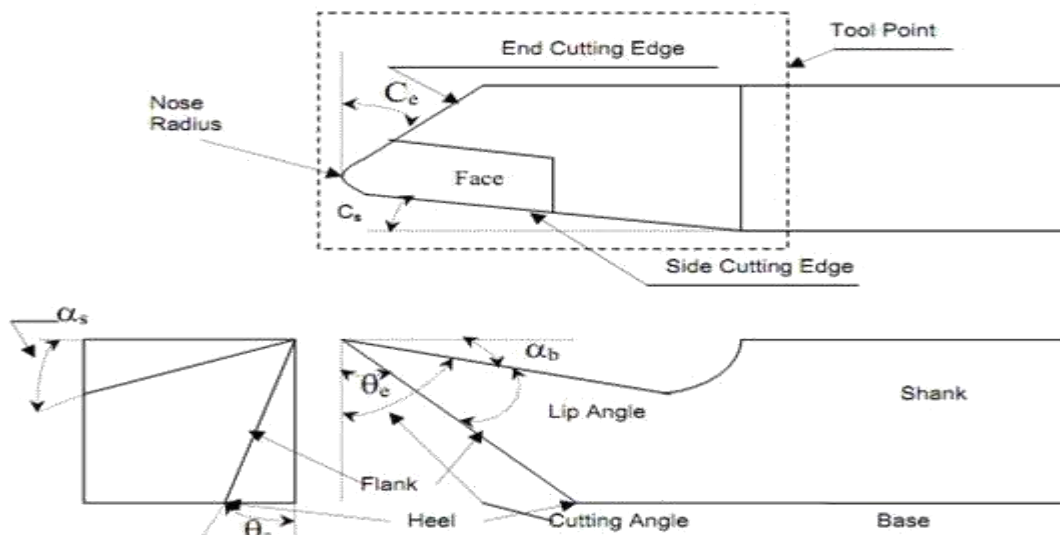

1. Rake angle: It is the angle formed between face of the tool and plane parallel to its base. If this inclination is towards shank, it is known as back rake or top rake. When it is measured

towards side of the tool, it is called side rake. These rake angles guide the chips away from the cutting edge, thereby reducing the chip pressure on the face and increasing the keenness of the tool, so that less power is required for cutting. An increased rake angle will reduce the strength of cutting edge. Therefore tools used for cutting hard materials are given small rake angles, whereas those used for soft metals contain large rake angles.

2. Negative rake angle: The above rake angles are called positive rake angles. When no rake is provided on the tool, it is said to have zero rake angle. When the face of the tool is so ground that it slopes upwards from the point, it is said to contain a negative rake. It reduces keenness of the tool and increases the strength of cutting edge. Such rake is usually provided on carbide tipped tools when they are used for machining extra- hard surfaces, hardened steel parts and for taking intermittent cuts. The values of negative rake on these tools normally vary from 5° to 10° .

3. Lip angle: The angle between the face and flank of the tool is known as Lip angle. It is also called angle of keenness of the tool. Strength of the cutting edge or point of the tool is directly affected by this angle. Larger the lip angle, stronger will be cutting edge and vice-versa. This angle varies inversely as the rake angle. It is only for this reason that when harder metals are to be machined a stronger tool is required, the rake angle is reduced and consequently the lip angle is increased. This calls for reduced cutting speeds, which is disadvantage. The lip angle is therefore kept as low as possible without making the cutting edge so weak that it becomes unsuitable for cutting.

4. Clearance angle: It is the angle formed by the front or side surface of the tool which are adjacent and below the cutting edge when the tool is held in a horizontal position. It is the angle between one of these surfaces and a plane normal to the base of the tool. When the front surface is considered it is called front clearance and when the surface below cutting edge is considered, the angle formed is known as side clearance angle. The purpose of providing front clearance is to allow the tool to cut freely without rubbing against the surface of the job. The side clearance is to direct the cutting thrust to the metal area adjacent to the cutting edge.

5. Relief angle: It is the angle formed between flank of the tool and a perpendicular drawn from the cutting point to the base of the tool.

6. Cutting angle: The total cutting angle of the tool is the angle formed between the tool face and a line drawn through the point, which is a tangent to the machined surface of the work at that point. Its correct value depends upon the position of the tool in which it is held in relation to the axis of the job.

7. Nose radius: If the cutting tip of a single point tool carries a sharp cutting point, the cutting tip is weak. It is therefore highly stressed during the operation, may fail or lose its cutting ability soon and produces marks on the machined surface. In order to prevent these harmful effects the nose is provided with a radius, called Nose radius. It enables greater strength to cutting tip, a prolonged tool life and superior surface finish on the work piece. As the value of this radius increases, a higher cutting speed can be used.

If it is too large, it may lead to chatter. So a balance has to be maintained. Its value normally varies from 0.4mm to 1.6mm depending upon several factors like depth of cut, amount of feed, type of cutting and type of tool.

Chip Formation:

Chips are formed due to tearing and shearing. In the chip formation by tear, the work piece material adjacent to the tool face is compressed and crack runs ahead of the cutting tool and towards body of the work-piece. The chip is highly deformed and the work-piece material is relatively under formed. Cutting takes place intermittently and there is no movement of the work piece material over the tool face.

In chip formation by shear, there is a general movement of the chip over tool face.

The grains of metal ahead of cutting edge of tool start elongating along line AB and continue to do so until they are completely deformed along line CD. The region between the lines AB and CD is called shear zone. After passing over shear zone, the deformed metal slides along the tool face due to the velocity of the cutting tool.

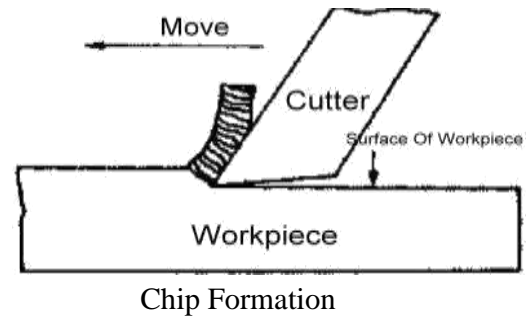

The angle made by plane of shear with the direction of tool travel is known as shear angle ϕ . Its value depends on the material being cut and the cutting conditions. If ϕ is small, path of shear will be long, chips will be thick and the force required to remove the layer of metal of given thickness will be high and vice-versa.

Types of chips:

Every machining operation involves the formation of chips, the nature of chips differs from operation to operation, properties of work-piece material and cutting condition.

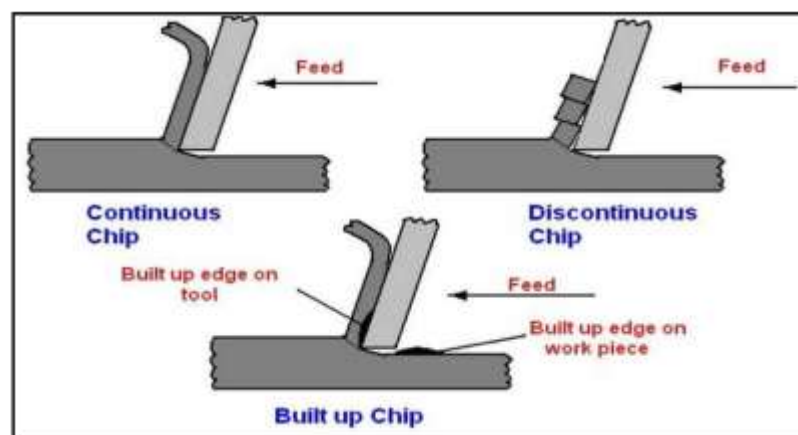

Chips are formed due to cutting tool, which is harder and more wear resistant than the work-piece material, relative motion between tool and work-piece, sufficient force and power to overcome the resistance of work-piece material. The chips are formed by the deformation of the metal lying ahead of cutting tool edge by a process of shear. Basically there are three types of chips

- 1. Discontinuous chips:** This type of chips is produced during machining of brittle materials like cast-iron and bronze. These chips are produced in the form of small segments.

In machining of such materials, as the tool advances forward, the shear-plane angle gradually reduces until the value of compressive stress acting on the shear plane becomes too low to prevent rupture. At this stage, any further advancement of the tool results in the fracture of

the metal ahead of it, thus producing a chip. With further advancement of the tool, the processes of metal fracture and production of chips goes on repeatedly producing discontinuous chips. Such chips are also sometimes produced in machining of ductile materials, when low cutting speeds are used and adequate lubrication is not provided. This causes excessive friction between the chip and tool face, leading to fracture of chip in small segments. This will also result in excessive wear on the tool and poor surface finish on the work-piece. Other factors responsible for production of discontinuous chips are smaller rake angle on the tool and too much depth of cut.

2. Continuous chip: This type of chip is produced while machining a ductile material, like mild steel and copper at very high cutting speed and minimum friction between the chip and the tool face. The friction at the chip-tool inter face can be minimized by polishing the tool face and adequate use of coolant. The basis of production of a continuous chip is the continuous plastic deformation of the metal ahead of the cutting tool, the chip moving smoothly up the tool face. Other factors responsible are bigger rake angle, finer feed and keen cutting edge of the tool.

3. Continuous chip with built-up edge: It is very similar to the continuous type and not as smooth as continuous chip. It has a built-up edge adhering on nose of the tool, which changes the effective geometry of cutting. It is obtained by machining ductile metals with high speed tools at ordinary cutting speeds, thus introducing high friction between the chip and tool face. The form and size of such an edge depends largely on the cutting speed, being absent at very low and very high cutting speeds. This type of chip results in poor surface finish. The normal reaction of the chip on the tool face is quite high, and is maximum at the cutting edge or nose of the tool. This gives rise to an excessively high temperature and the compressed metal adjacent to tool nose gets welded to it. The chip is also sufficiently hot and gets oxidized as it comes off the tool and turns blue in colour. The extra metal welded to tool nose or point of the tool is called **built-up edge**.

This metal is highly strain hardened and brittle. With the result, as the chip flows up the tool, the built-up edge is broken and carried away with the chip while the rest of it adheres to the surface of the work-piece, making it rough. Due to the built-up edge the rake angle is also altered and so is the cutting force. The common factors responsible for formation of built-up edge are low cutting speed, excessive feed, small rake angle and lack of lubricant.

Adverse effects of built-up edge formation:

- Rough surface finish on the work-piece.
- Fluctuating cutting force, causing vibrations in cutting tool.
- Chances of carrying away some material from the tool by the built-up surface, producing crater on the tool face and causing tool wear.

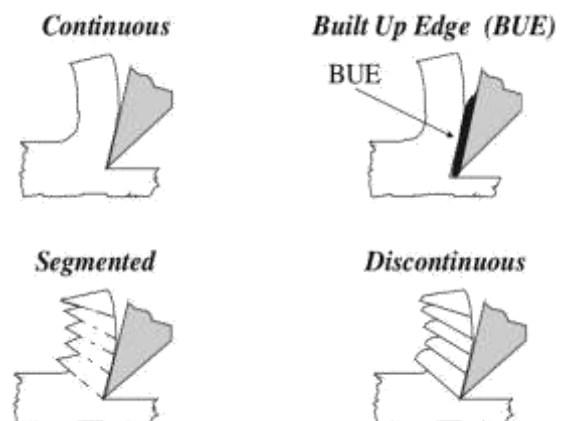

Precautions for avoiding the formation of built-up edge:

- a) The co-efficient of friction at the chip-tool interface should be minimized by means of polishing the tool face and adequate supply of coolant during the cutting operation.
- b) The rake angle should be kept large.
- c) High cutting speeds and low feeds should be used, because at high speeds the strength of the weld becomes low. Similarly, at very high temperature also the strength of the weld becomes low.

Chip-Breakers:

The chips produced during machining at higher speeds in machining of high tensile strength materials, need to be effectively controlled. Carbide tipped tools are used in case of higher speeds and due to high temperature the chip will be continuous of blue colour and take the shape of coil. Such a chip, if not broken in to parts and removed from the surroundings of the metal cutting area, will adversely affect the machining in the following way.

- a) Adversely affect tool life by spoiling the cutting edge, creating crater and raising the temperature.
- b) Lead to poor surface finish on the work-piece.
- c) The chips get curled around the rotating work-piece and cutting tool, it may be hazardous to the machine operator.
- d) If large and continuous coil is allowed to be formed it may endanger the machine and even the work place.
- e) Very large coils offer a lot of difficulty in their removal.

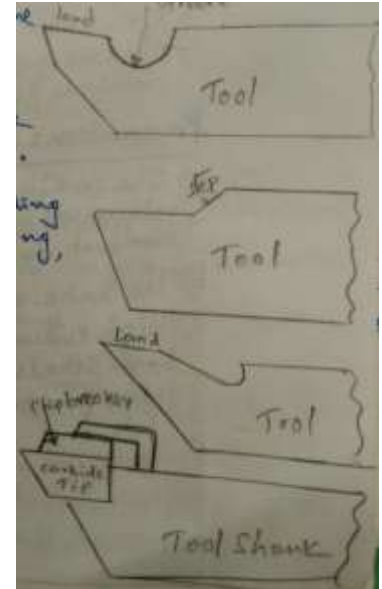

While machining materials like brass and cast-iron continuous chips of above type are not produced. But in case of continuous chips, by using chip breakers, we can overcome the above difficulties and adverse affects. The chip breakers break the produced chips in to small pieces. The work hardening of the material of the chip makes the work of the chip breakers easy.

The common methods used for chip breaking are:

i) By control of tool geometry i.e. grinding proper back rake and side rake angles according to the speeds and feeds used.

ii) By obstruction method i.e. by inters posing a metallic obstruction in the path of the coil. The following types of chip breakers are commonly used:

a) Groove type: It consists of a grinding groove on the face of the tool, behind the cutting edge, leaving a small land near the tip.

b) Step type: It consists of a grinding a step on the face of the tool, adjacent to the cutting edge.

c) **Secondary rake type:** It consists of providing a secondary rake on the tool, through grinding, together with a small step.

d) **Clamp type:** This type of chip breaker is very common with the carbide tipped tools. The chip breaker is a thin and small plate, which is either brazed to or held mechanically on the tool face.

Cutting Speed, Feed And Depth Of Cut:

Cutting speed of a tool can be defined as the rate at which its cutting edge passes over the surface of the work-piece in unit time. It is normally expressed in terms of surface speed in meters per minute.

In machining it is important as it considerably affects the tool life and efficiency of machining. Selection of proper cutting speed has to be made very judiciously. If it is too high, the tool gets over heated and its cutting edge may fail, needing regrinding. If it is too low, too much time is consumed in machining and full cutting capacities of the tool and machine are not utilized, resulting in lowering of productivity and increasing the production cost.

Feed of the cutting tool can be defined as the distance it travels along or in to the work-piece for each pass of its point through a perpendicular position in unit time. In turning operation of lathe, it is equal to the advancement of the tool corresponding to each revolution of work. In planning it is the work, which is fed and not the tool. In milling work, the feed is considered per tooth of the cutter.

The cutting speed and feed of a cutting tool is largely influenced by the following factors:

1. Material being machined.
2. Material of the cutting tool.
3. Geometry of the cutting tool.
4. Required degree of surface finish.
5. Rigidity of the machine tool being used
6. Type of coolant being used

Depth of cut: It is indicative of the penetration of the cutting edge of the tool in to the work-piece material in each pass, measured perpendicular to the machined surface i.e. it determines the thickness of metal layer removed by the cutting tool in one pass.

Example: In turning operation on a lathe it is given by

$$\text{Depth of cut} = \frac{D-d}{2}$$

Where D = Original diameter of the work-piece in mm

D = Diameter obtained after turning in mm in one pass.

Coolants: coolants are used in metal machining to perform the following main functions.

1. They cool the tool and the work piece.
2. They provide lubrication between the tool and work piece and tool and chips.
3. They prevent the adhesion of chips to the tool or work piece or both.

Cooling of the tool and work piece is required in order to dissipate the heat generated during machining. The sources of heat generation during metal cutting are the following.

1 Friction: A lot of friction always takes place between the cutting tool and the work piece and between the tool face and the chips passing over it. The total amount of heat generated depends upon many factors viz. cutting speed, feed, tool material, depth of cut and metal being machined. The heat so generated is known as heat of friction.

2. Plastic deformation of metal: Cutting tool exerts high pressure on the adjacent metal grains which due to this pressure start slipping along their planes of weakness. This causes deformation of all of them. The action of slipping of these grains in contact with one another causes friction, leading to the generation of the heat of deformation. The total amount of heat generated again depends upon the cutting speed, feed, depth of cut and the metal being machined. Higher speeds, feeds, more depth of cut, tougher materials contribute to greater heat generation.

3. Chip distortion: In machining, as the cut proceeds and the chips curl out, the inside and the outside grain of the chip metal are subjected to compression and tension respectively. This causes distortion of the chip grains and the chips leading to a sort of internal friction amongst the grains and consequently generation of heat of chip distortion. The amount of heat generated depends on feeds and depth of cut. Heavier the feed and deeper the cut, the longer will be the area of cross-section of the chip and more distortion amongst the grains, resulting in higher amount of heat generation.

Machinability: Gives the idea of ease with which it can be machined. The parameters influencing the machinability of a material are:

1. Physical Properties of material.
2. Mechanical Properties of material.
3. Chemical composition of material.
4. Micro-Structure of material
5. Cutting conditions.

Machinability of the material depends on various variable factors such as

1. Tool Life: Longer tool life, it enables at a given cutting speed on the speed the better is the machinability.
2. Surface finish: It is indirectly proportional, i.e. better surface finish the higher is the machinability.
3. Power Consumption: Lower power consumption per unit of metal removal-better machinability.
4. Cutting Forces: Lesser amount of cutting force required for removal of higher volume of metal under standard conditions, the higher will be the machinability.
5. Shear angle: Larger shear angle denotes better machinability.

6. Rate of metal removal under standard cutting conditions.

Tool Life:

Tool life can be defined on the time interval for each tool works satisfactorily between into successive grindings. These are three common ways of expressing Tool life.

1. As time period in minutes between two successive grindings.
2. In terms of no. of components machined between two successive grindings.
3. In terms of the volume of the material removed between two successive grindings.

The method of assessing tool life in terms of the volume material removed per unit of time in a practical one.

$$\text{Volume of metal removed/min} = \pi D t f N \text{ mm}^3 / \text{min}$$

Where D = Dia of work piece in mm

t = depth of cut in mm

f = feed rate mm/rev

N = no. of revolutions of work per min.

$$\text{If } T \text{ be the times in minutes to tool failure} = \pi D t f N T \text{ mm}^3$$

$$\text{We know the cutting speed } V = \frac{\pi D N}{1000} \quad \pi D N = V * 1000$$

$$\text{Total Volume of metal removed to tool life} = V * 1000 * t * f * T \text{ mm}^3$$

$$\text{Therefore Tool life } T_L = V \times 1000 \times t \times f \times T \text{ (mm}^3\text{)}$$

Factors affecting Tool Life:

1. Cutting Speed.
2. Feed and Depth of cut.
3. Tool Geometry.
4. Tool Material.
5. Work Material.
6. Nature of Cutting.
7. Rigidity Machine tool and work.
8. Use of cutting fluids.

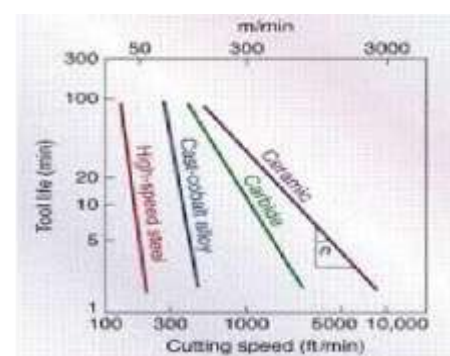
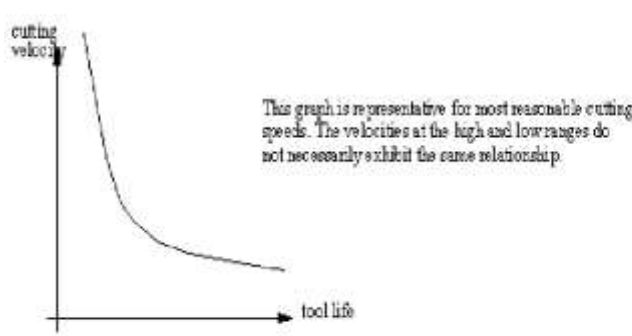

1. Effect of cutting speed:

The tool life varies inversely on cutting speed i.e. higher the cutting speed the smaller the tool life.

$$V T^n = C$$

V = Cutting speed m/min.

T = Tool life minutes.

n = An exponent – Its value depends on the tool material.

C = Machining Constant.

n = 0.1 to 0.15 HSS Tools

= 0.2 to 0.5 Carbide Tools

= 0.6 to 1.0 Ceramic Tools.

2. Effect of feed rate and depth of cut: It will appreciably effect in reduction in tool life.

$$V = \frac{257}{T^{0.19} f^{0.86} t^{0.8}} \text{ m/min}$$

V = Cutting Speed m/min

T = Tool Life in min

F = Feed rate mm/min

t = Depth of a cut in mm

For a given Tool life $V = \frac{C}{f^a t^b}$ C = Constant

If the tool life is considered on constant, the cutting speed will decrease if the feed rate and depth of cut are increased.

3. The Geometry: Geometrical parameters (Tool angles) of a cutting tool influence its performance. The Rake angle has mixed effect. If it is increased, the amount of heat generated are reduced and help in increasing the life of cutting tool. But if it is very large the cutting edge is weakened and also its capacity to conduct the heat is reduced results in reduction in mechanical strength and lowering tool life. For effective economical tool life it is necessary to strike a balance. The optimum value of rake angle needs to be used. This value varies from -5^0 to $+10^0$. The minus sign indicates negative rake i.e. rake angle sloping up words from Tip. Tools carrying negative rake angle provide a stronger cutting edge and hence a stronger tool. Carbide and ceramic tools are generally provided – ve angle.

Similarly relief angle or clearance angle bn influence the tool performance. These angles are provided on cutting tools to prevent the rubbing of tool flank against the machine work surface. They thus help in lowering the amount of heat generated and therefore increasing the tool life. But very large relief angles beyond certain level results in weakening of tool resulting in reduction of tool life.

Therefore a balance needs to be struck and only optimum value should be used. The angles normally vary from 5° to 8° but in special causes as carbide tipped tools up to 10° .

The two cutting edge angles also have their influence on tool performance. The front cutting edge angle/end cutting edge angle effects the tool wear. Up to a certain optimum value an increase in this angle permits the higher speeds without an adverse effect on tool life. But an increase beyond certain value will result in reduction of tool life. It generally varies from 5° to 8° . If the side cutting edge angle is smaller the higher speeds can be used. However it has complex effect on Tool life. A larger end cutting edge angle increases tool life.

- I. Inclination angle: Tool life increases with the increase in this angle up to an optimum value.
- II. Nose radius: While it increases the abrasion, it also helps in improving surface finish and tool strength and hence tool life.

4. Tool material: The main characteristics of good cutting tool material are its hot hardness, wear resistance, impact resistance, abrasion resistance, heat conductivity and strength etc. An ideal tool material is the one which will remove the largest volume of work material at all speeds. It is not possible to get truly ideal tool material. The tool material which can withstand max cutting temperature without losing its principal mechanical properties (sply hardness) and geometry will ensure max tool life. The higher hot hardness and toughness in tool material, the longer the tool life.

5. Work Material: The micro-structure of work material is significant as it directly effects the hardness of material. Higher the hardness of the work material greater will be the tool wear and shorter will be the tool life. In machining pure metals, because of their tendency to stick to the tool face. Specially at high temperatures results in more friction and high amount wear on tool and therefore shorter tool life.

6. Nature of cutting: Tool life is affected by nature of cutting i.e. whether it is continuous or intermittent. In the intermittent cutting the tool is subjected to impact loads and may give away much earlier than expected until it is made strong and tough. In continuous cutting similar tool will have relatively longer life.

7. Rigidity of machine tool and work : Both the machine tool and work – piece should remain rigid during the machining operation. If not vibrations will take place and the cutting tool will be subjected to intermittent cutting, instead of continuous cutting. This will result in impact loading of tool and therefore shorter life.

8. Use of cutting fluids: Cutting fluids are used in machining work for helping the efficient performance of the operation. They are used either in liquid or gaseous form. They assist the operation by cooling the tool and work, reducing the friction, improving the surface finish, helping in breaking the chips and washing them away etc. These factors help in improving the tool life, permitting higher metal removal rate and improving the quality of surface finish.

Characteristics Of Cutting Tool Materials:

The materials used for manufacture of cutting tools should possess the following characteristics:

1. Ability to retain its hardness at elevated temperatures called hot hardness.

2. Ability to resist shock, called toughness.
3. High resistance to wear to ensure longer tool life.
4. Low co-efficient of friction at the chip –tool interface, so that the surface finish good and wear in minimum.
5. Should be cheap.
- 6 Should be able to be fabricated and shaped easily.
7. If it is to be used in the form of brazed tips, its other physical properties like tensile strength, thermal conductivity, co efficient of thermal expansion and modulus of elasticity etc. should be as Close To The Shank Material As Possible To Avoid Cracking.

Cutting Tool Materials

The following materials are commonly used for manufacturing the cutting tools, selection of a particular material will depend on the type of service it is expected to perform.

1. High Carbon Steel: Plain carbon steels having a carbon percentage as high as 1.5% are in common use as tool materials for general class of work. For high production work they are not considered as they are not able to withstand very high temperature, hence they can't be used at high speeds. The required hardness is lost by them at temperature 200° - 250° C. They are also not highly wear resistant. They are used mainly for hand tools as they are less costly, easily forgeable and easy to heat treat.

High carbon medium alloy steels are more effective than plain high carbon steels. These steels in additions to carbon content are provided better hot hardness, higher impact resistance, higher wear resistance by adding small amount of Tungsten, Chromium, Molybdenum, Vanadium etc. Which improves the performance and able to operate temperatures of 350° C.

2. High Speed Steel: It is a special alloy-steel containing the alloying elements like Tungsten, Chromium, Vanadium, Cobalt and Molybdenum up to 25%. These alloying elements increase its strength, toughness, wear resistance, cutting ability and retains it's hardness at elevated temperature of 550° c - 600° c on account of these added properties the high speed steel tools are capable of operating at 2 to 3 times higher cutting speeds than high carbon steel tools.

The most commonly used high speed steel has composition alloying elements as 18-4-1 i.e. 18%W, 4%Cr, and 1%V.

3. Cemented Carbides: These Carbides are formed by the mixture of Tungsten, Titanium with Carbon. The carbides in the powder form are mixed with Cobalt which acts as binder. The mixture with powder metallurgy process, sintered at high pressures of 1500kg/sq cm to 4000kg/sq cm and temperatures of above 1500° C is shaped in to desired forms of tips. These Carbide tips are then brazed or fastened mechanically to the shank made of medium Carbon steel. These cemented carbides possess a very high degree of hardness and wear resistance. They are able to retain this hardness at temperature up to 1000° C with the result, the tools tipped with cemented carbide tips are capable of operating at speeds 5 to 6 times higher than those of high speeds.

4. **Stellite:** It is a non ferrous alloy mainly of Cobalt, Tungsten and Chromium. Other elements added in varying proportions are Tantalum, Molybdenum and Boron. It has good shock and wear resistance and retains its hardness at a red heat up to 920°C . It is used for machining materials like hard bronzes, cast and malleable Iron etc. Tools made of Stellite are capable of operating at speed up to 2 times more than those of common high speed steel tools. Only grinding can be used for machining it effectively.

A satellite may contain 40-50% Co, 15-35%Cr, 12-25%W and 1-4%Carbon.

5. **Ceramics:** The introduction of ceramic material as a cutting tool material is a latest development in the field of tool metallurgy. It mainly consists of Aluminum oxide which is comparatively much cheaper than any of the chief constituents of cemented Carbides. Boron nitrides in powdered form are added and mixed with Aluminum oxide powder and sintered together at a temperature of 1700°C . They are then compacted in to different tip shapes. Tools made of ceramic material are capable of withstanding high temperatures, without losing their hardness up to 1200°C . They are much more wear resistant than cemented carbide tools. They are more brittle and low resistance to bending. They can't be used for rough machining work and mainly used for finishing operations. They are capable of removing 4 times more material than Tungsten carbide tools and 2-3 times high cutting speeds under similar conditions. No coolant is needed while machining with ceramic tools.

6. **Diamond:** It is the hardest material known and used as cutting tool material. It is brittle and low resistance to shock but it is highly wear resistant. Diamonds are used for only light cuts on materials like Bakelite, Carbon, Plastics, Aluminum and Brass etc. Because of low coefficient of friction they produce a high grade of surface finish. Because of high cost only limited use in tool industry.



Carbide Tips:

Q : What are the throw away carbide tips? What are their advantages? What are the basic requirements?

Throw away Carbide tips are made in a variety of shapes and vary in thickness from 3mm to 12mm and size from 10 to 15mm^2 (mm square). Proper arrangements in the form of holes etc are made to secure them on the tool holders.

Positive rake Carbide tips have 3 or 4 cutting edges, which are ground to produce 5 to 8° relief angle. These can be used individually before tip becomes unusable.

In negative rake Carbide tips, the relief angle is created by placing them suitably on the tool holder. These thus have the advantage of providing 6 to 8 usable edges, because all the edges are prepared at right angles. However the second side of the tip can be used only if the first side has not become rough due to wear as otherwise it can't be flat against the loading surface on the tool holder.

Throw away Carbide tips are quite cheap and as 4 to 6 edges can be used before it is thrown, there is lot of economy in using them.

The basic requirements of Carbide tips are: A pocket on the tool holder to locate the carbide tip positively and take the side longitudinal and end radial thrust from the cutting forces and also to ensure that new tip will cut to the same size.

- I. A solid seat for the bottom of the carbide tip to take the tangential force and also to ensure that new tip will cut to the same size.
- II. A clamp to hold the tip formally against the bottom of the pocket and it form being pulled out.

Chip Thickness Ratio:

During cutting action of a metal, the thickness of the deformed or upward flowing chip is more than the actual depth of cut. It is because the chip flows upwards at a slower rate than the velocity of the cut. The velocity of the chip flow is directly affected by the shear plane angle. The smaller the shear plane angle the slower will be the chip flow – velocity and therefore longer will be the thickness of the chip.

t = chip thickness prior to deformation

t_c = chip thickness after deformation

$t_c > t$, The chip thickness ratio $r = \frac{t}{t_c}$

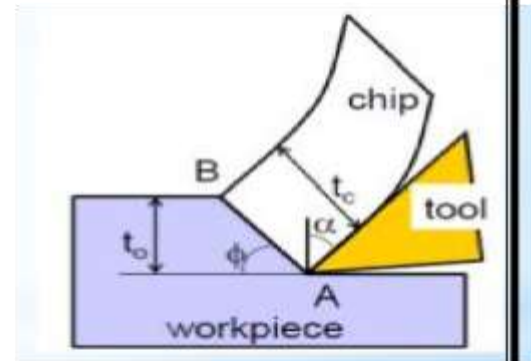

Since t_c is always greater than t , the value of chip thickness ratio r is always less than unity. The higher the value of r , the better is supposed to be cutting action. The reverse of r is known as chip reduction coefficient. If k is the chip reduction coefficient

$$K = \frac{1}{r}$$

In orthogonal cutting the width of the chip equals the width of the cut. Considering specific gravity of the metal as constant, the volume of the chip produced will be equal to the volume of the metal cut. Width of both being equal, the product of the chip thickness and its length will, therefore be equal to the product of the thickness of the metal cut and length of metal cut. If L_1 and L_2 are lengths of the metal cut and chip respectively.

$$t \times L_1 = t_c \times L_2$$

$$\frac{t}{t_c} = \frac{L_2}{L_1} \quad \text{But} \quad \frac{t}{t_c} = r$$

$$r = \frac{t}{t_c} = \frac{L_2}{L_1}$$

$$k = \frac{1}{r} = \frac{t}{t_c} = \frac{L_2}{L_1}$$

We have two right angled triangles OAP and OBP

Considering the orthogonal triangle OAP

$$\frac{AP}{OP} = \sin \theta \quad OP = \frac{AP}{\sin \theta} = \frac{t}{\sin \theta} \quad \text{----- (1)}$$

Considering the right angled triangle OBP

$$\frac{BP}{OP} = \sin BOP = \sin(90 - \phi + \alpha) = \cos(\phi - \alpha)$$

$$OP = \frac{BP}{\cos(\phi - \alpha)} = \frac{t_c}{\cos(\phi - \alpha)} \quad \text{_____ (2)}$$

Now by equations (1) & (2)

$$OP = \frac{t}{\sin \phi} = \frac{t_c}{\cos(\phi - \alpha)}$$

$$\frac{t}{t_c} = \frac{\sin \phi}{\cos(\phi - \alpha)} \quad \text{i.e. } r = \frac{\sin \phi}{\cos(\phi - \alpha)} \quad \text{_____ (3)}$$

$$r = \frac{\sin \phi}{\cos \phi \cos \alpha + \sin \phi \sin \alpha}$$

$$r(\cos \phi \cos \alpha) + r(\sin \phi \sin \alpha) = \sin \phi$$

$$r \frac{\cos \phi \cos \alpha}{\sin \phi} + r \frac{\sin \phi \sin \alpha}{\sin \phi} = 1$$

$$r \frac{\cos \alpha}{\tan \phi} + r \sin \alpha = 1$$

$$r \frac{\cos \alpha}{\tan \phi} = 1 - r \sin \alpha$$

$$\tan \phi = \frac{r \cos \alpha}{1 - r \sin \alpha} \quad \text{_____ (4)}$$

$$\tan \phi = \frac{\frac{t}{t_c} \cos \alpha}{1 - \frac{t}{t_c} \sin \alpha} \quad \text{_____ (5)}$$

❖ **Merchants Force Diagram:**

F_H = Horizontal cutting force exerted by the tool on work piece.

F_V = Vertical or tangential force which helps in holding the tool in position and acts on tool

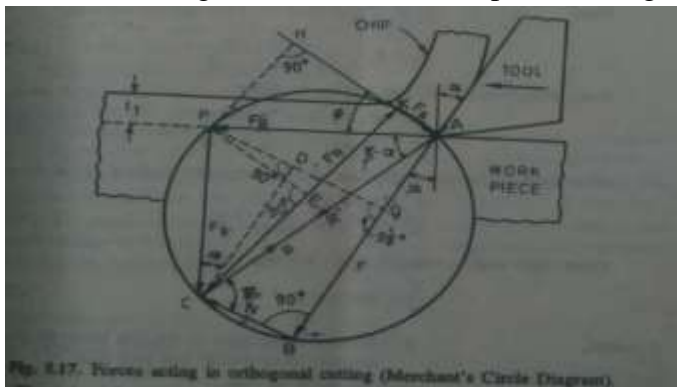

nose.

Merchant force diagram

$$F = AQ - QB = AQ - DC = F_H \sin \alpha - F_V \cos \alpha \quad \text{_____ (1)}$$

$$N = QD = PQ - PD = F_H \cos \alpha - F_V \sin \alpha \quad \text{_____ (2)}$$

$$F_s = AH - HK = AH - PE = F_H \cos \phi - F_V \sin \phi$$

$$N_s = CE + EK = CE + PH = F_V \cos \phi +$$

$$F_H = AC \cos(\beta - \alpha) = R \cos(\beta - \alpha)$$

$$F_s = R \cos$$

$$\frac{F_H}{F_s} = \frac{R \cos(\beta - \alpha)}{R \cos(\phi + \beta - \alpha)}$$

$$F_H = F_s \frac{\cos(\beta - \alpha)}{\cos(\phi + \beta - \alpha)}$$

The tool face components are importance they enable the co efficient to friction for the tool face ($\mu = \tan \beta$) to be determines β is the angle of friction at the rank surface.

$$\mu = \frac{F}{N} = \frac{F_A \sin \alpha + F_V \cos \alpha}{F_H \cos \alpha - F_V \sin \alpha} = \frac{\cos \alpha}{\cos \alpha}$$

$$= \frac{F_H \tan \alpha + F_V}{F_H - F_V \tan \alpha}$$

μ is co efficient of friction between tool face and upward sliding chip.

$$\frac{F_V}{F_H} = \tan(\beta - \alpha)$$

F_V and F_H can be easily measured by strain gauges or force dynamo meters.

❖ Tool Signature

The term tool signature is used to denote a standardized system of specifying the principle tool angles of a single point cutting tool.

Some common systems are:

1. American (ASA) System.
2. British System.
3. Continental System.
4. International System.

I. Reference Planes: The following two systems of references planes are used to describe the geometry and locate the different parameters of a single point cutting tool.

1. The Co-Ordinate System: This system consist of three principal reference planes. The horizontal plane which contains the base of the shank of the cutting tool is known as the **Base Plane**. The second reference plane is a vertical plane, normal to the base plane, and parallel to the direction of feed (f) of the cutting tool. It is called **Longitudinal Plane** (x, x^I). The third reference plane called the **Transverse Plane** (y, y^I) is perpendicular to both the above reference planes and is parallel to the transverse motion of the tool. i.e. the depth of cut(d).

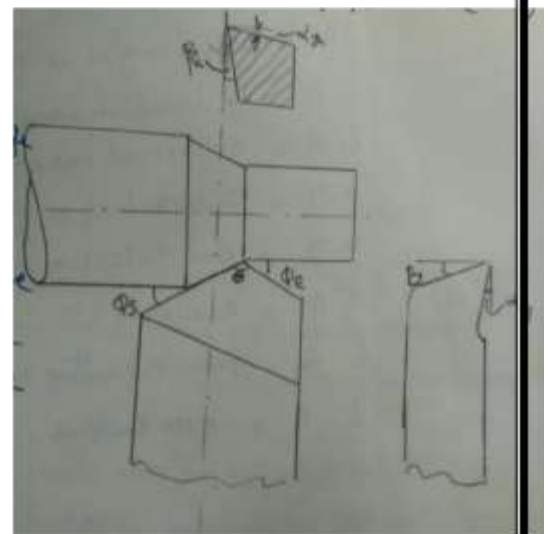

This combination of reference planes is known as co ordinate system of reference planes. This system having been adopted by American **Standard Association (ASA)** is known as ASA System.

The principal angles in ASA System.

1. α_y = Top rake angle / Back rake angle.
2. α_x = Side rake angle.
3. β_y = End relief / Clearance angle.
4. β_x = Side relief / Clearance angle.
5. ϕ_e = End cutting edge angle.
6. ϕ_s = Side cutting edge angle.
7. θ = Nose radius / angle.

2. THE ORTHOGONAL SYSTEM :(OR) ORTHOGONAL RAKE SYSTEM(ORS):

In this system of reference planes it is assumed that the cutting tool is operating against the work piece. There are three main reference planes. The Horizontal Plane, contains the base of the cutting tool and is known as **Base Plane**. The second plane, which is perpendicular to the base plane, contains the principal cutting edge (c) and is called the **Cutting Plane**. The third plane which is perpendicular to both the above planes, is known as Orthogonal System of Reference Planes or Orthogonal Rake System (ORS).

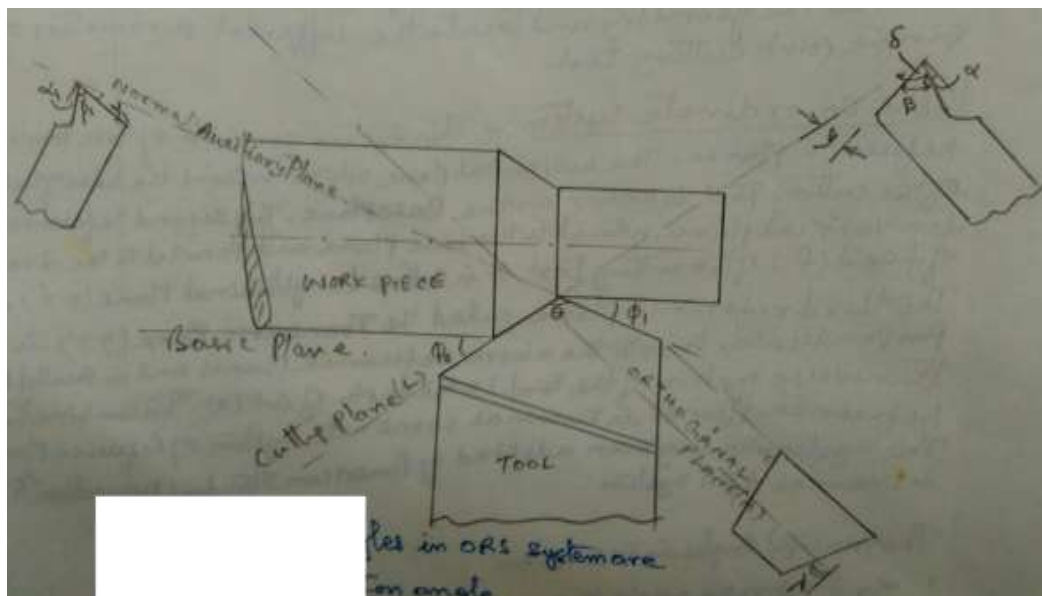

The principal angles in ORS System are.

1. λ = Inclination angle.
2. α = Orthogonal Rake Angle.
3. γ = Side relief angle.
4. γ_1 = End relief angle.
5. ϕ_1 = Auxiliary cutting edge angle.
6. ϕ_0 = Principal cutting edge angle/approach angle.
7. R = Nose Radius.

FORCE RELATIONSHIP IN ORTHOGONAL CUTTING:

A number of forces act on the chip during metal cutting. The relationship among these forces were established by merchant.

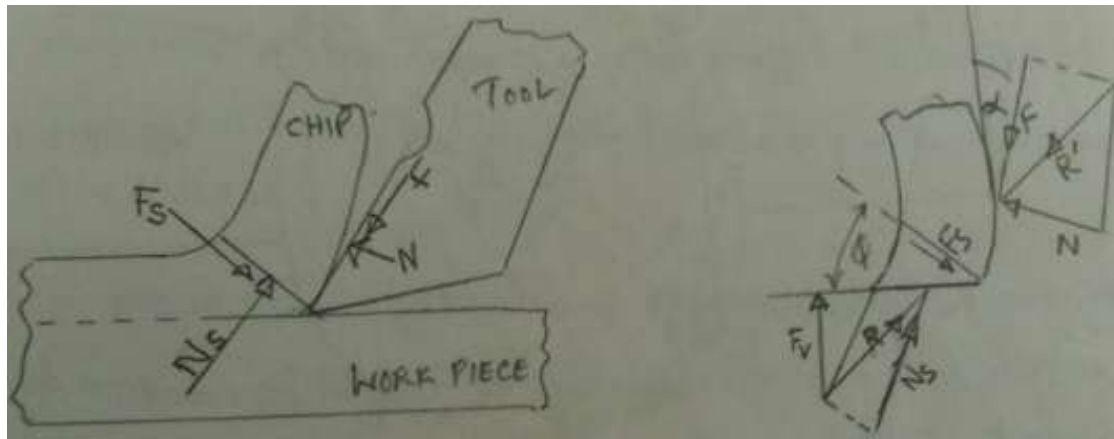

The forces acting on the chip in orthogonal cutting are represented as follows.

F_s = Metal resistance to shear in chip formation, acting along shear plane.

N_s = Backing up force exerted by the work piece on the chip, acting normal to shear plane.

N = Force exerted by the tool on the chip, acting normal to tool face.

$F = \mu N$ = Frictional resistance of the tool against the chip flow, acting along the tool face. μ being the co-efficient of friction between tool face and chip.

$$\mu = \frac{F}{N}$$

It will be observed that F_s and N_s can be easily replaced by their resultant r and force F and N by their resultant R^I . Thus all these forces are resolved to only two forces R and R^I . For equilibrium, these forces R and R^I should be equal, act opposite to each other and should be collinear i.e.

$$\vec{R}^I = \vec{F} + \vec{N}$$

$$\vec{R} = \vec{F}_s + \vec{N}_s$$

$$= \vec{F}_H + \vec{F}_V$$

$$\vec{R} = \vec{R}^I$$

The two triangles of forces of the above free body diagram have been combined together one called “Merchant Circle Diagram” of cutting forces in which the following new components figure.

F_H = Horizontal cutting force exerted by the tool on work piece.

F_V = Vertical force which helps in holding the tool in position and acts on the tool nose.

These two forces can be easily be found out with the help of strain gauges or

Force dynamometers. The angle is also is a known quantity.

α is the rake angle of the tool. ϕ also can be determined with the help of the equation $\tan\phi = \frac{r \cos\alpha}{1-r \sin\alpha}$. When all these four values i.e. F_H , F_V , α and ϕ are known, all other forces can be easily calculated with the help of merchant circle diagram.

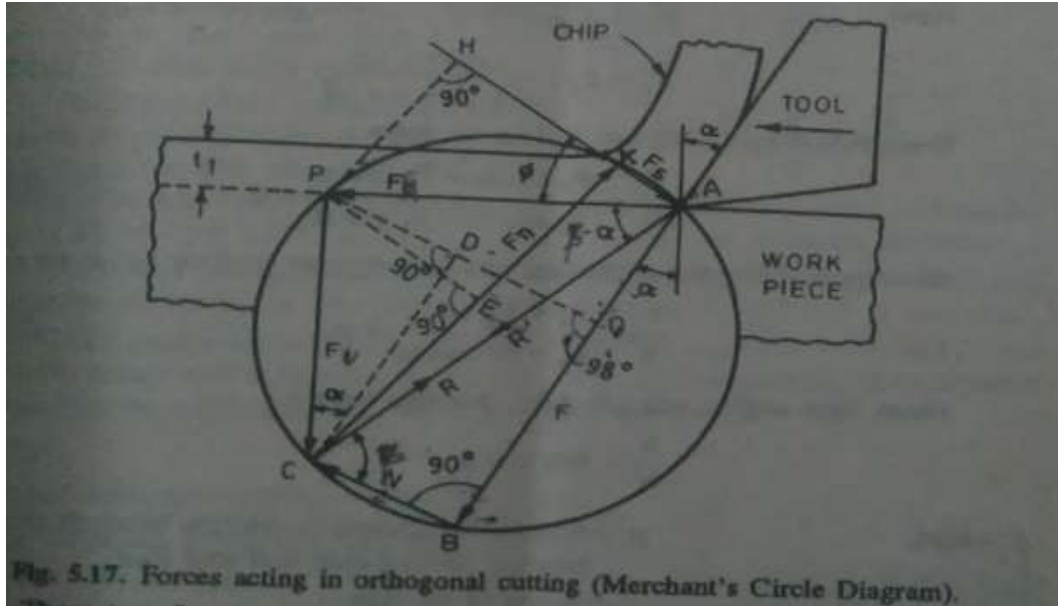

$$F = AQ+QB = AQ + DC = F_H \sin\alpha + F_V \cos\alpha \quad \underline{\hspace{2cm}} \quad (1)$$

$$N = QD = PQ - PD = F_H \cos\alpha - F_V \sin\alpha \quad \underline{\hspace{2cm}} \quad (2)$$

$$F_s = AH - HK = AH - PE = F_H \cos\phi - F_V \sin\phi \quad \underline{\hspace{2cm}} \quad (3)$$

$$N_s = CE + EK = CE + PH = F_V \cos\phi + F_H \sin\phi \quad \underline{\hspace{2cm}} \quad (4)$$

$$F_H = AC \cos(\beta-\alpha) = R \cos(\beta-\alpha) \quad \underline{\hspace{2cm}} \quad (5)$$

$$F_s = AC \cos(\phi+\beta-\alpha) = R \cos(\phi+\beta-\alpha) \quad \underline{\hspace{2cm}} \quad (6)$$

$$\frac{F_H}{F_s} = \frac{R \cos(\beta-\alpha)}{R \cos(\phi+\beta-\alpha)} \quad F_H = F_s \frac{\cos(\beta-\alpha)}{\cos(\phi+\beta-\alpha)} \quad \underline{\hspace{2cm}} \quad (7)$$

Equation (1) & (2) we have

$$\frac{F}{N} = \frac{F_H \sin\alpha + F_V \cos\alpha}{F_H \cos\alpha - F_V \sin\alpha} \frac{\cos\alpha}{\cos\alpha} = \frac{F_V + F_H \tan\alpha}{F_H - F_V \tan\alpha} \quad \underline{\hspace{2cm}} \quad (8)$$

From ΔABC $\frac{F}{N} = \tan\beta = \mu \quad \underline{\hspace{2cm}} \quad (9)$

$$\beta = \tan^{-1} \frac{F}{N} = \tan^{-1} \mu$$

μ = Kinetic coefficient of friction between chip and tool face.

β = Angle of friction

Further $\frac{CP}{AP} = \tan \alpha$

$$\frac{F_V}{F_H} = \tan(\beta - \alpha)$$

(10)

**Kinematic Drives Of Machine Tools:**

Every machine tool is required to perform one or both of the following functions kinematic functions:

1. To transmit motion from the input shaft to the output spindle.
2. To transform rotary motion in to translator or reciprocating motion or vice - versa

These transformations in a machine tool are achieved through a chine higher or lower pairs, which consist of the machine tool drive or drive mechanism. The term “**Drive**” includes all the systems of the transmission used in a machine tool to import cutting and feeding motions.

Types of Drives: Machine tool drives, based on different criteria, can be classified as follows:

1. According to the mode of power supply:
 - a) Individual Drive or Self-Contained Drive
 - b) Group Drive or Common Drive
2. According to the system of transmission:
 - a) Mechanical Drives – Belt & pulleys, Gear trains, Power Screws and nuts, Chains etc.
 - b) Electrical Drives
 - c) Hydraulic Drives
 - d) Pneumatic Drives
3. According to the type of motion imported by the drive:
 - a) Rectilinear Drive – Straight line Motion.
 - b) Rotary Drive – Circular Motion.
4. According to the regulation of spindle speeds:
 - a) Stepped Drive.
 - b) Stepless Drive.

Selection of drive depends upon production time, surface finish and accuracy required, optimum efficiency, power to weight ratio, simplicity of design with respect to maintenance, repair and control.

UNIT – II

Lathe removes undesired material from a rotating work piece in the form of chips with the help of a tool which in traversed a cross the work and can be fed deep in work. The tool material should be harder than the work piece. The work piece is held securely and rigidly on the machine. The cutting tool is rigidly held and supported in a tool post and is fed against the revolving work while the work revolves about its own axis the tool is made to move either parallel to it or at an inclination with their axis to cut the desired material. It produces cylindrical surface if it is fed at an inclination.

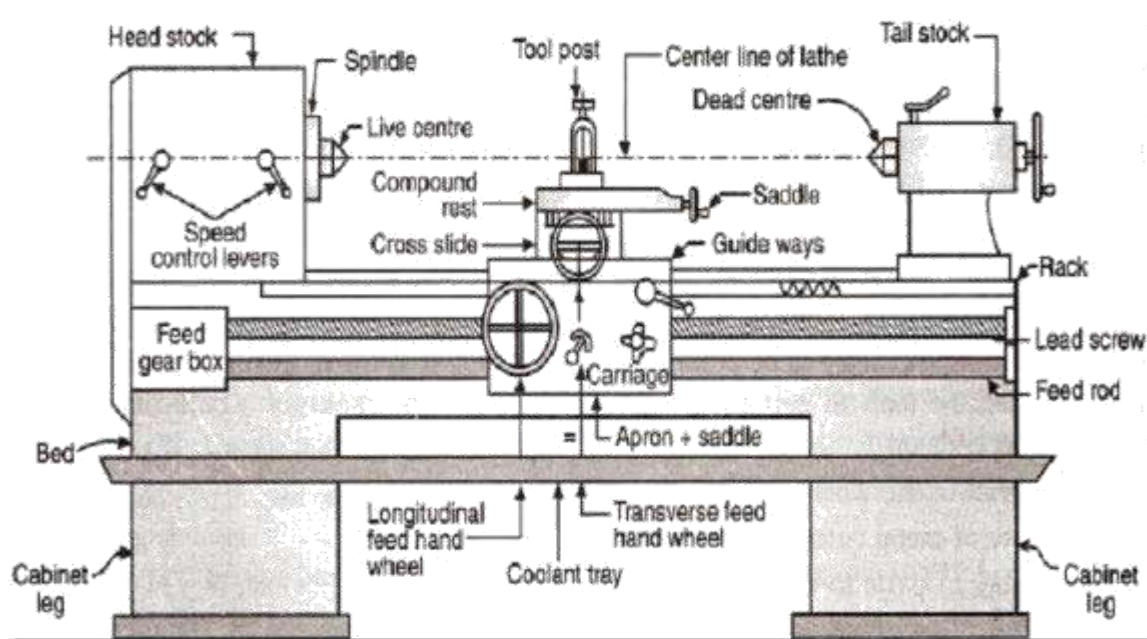

Specification of a Lathe: A lathe is generally designed by

- a) Swing i.e. the largest work diameter that can be swing over the lathe bed.
- b) Distance between head stock centers.

Classification of a Lathe: According to size, design, method of drive, arrangement of gears, different precision classes and purpose.

i) Speed Lathe: It is so named because of the very high speed of head stock spindle. It is a simplest form of lathe and consists a simple head stock, a tail stock and tool post. It has no gear box, lead screw and carriage. Tools are hand operated. Cone-pulley is the only source

provided for the speed variation of the spindle. Mainly used for wood turnig, metal spinning and polishing operations.

ii) Engine Lathe or Centre Lathe: It is most widely used one. Its name is derived from the fact that early machine tools were driven by a separate engine or from a central engine with over head belts and shafts. The stepped cone- pulley or geared head are often used for varying the speed of lathe spindle. A tail stock is provided to facilitate holding the work between the centers and permit the use of tools like drills and taps etc. The cutting tools are controlled either by hand or by power and can be fed both in cross and longitudinal directions with ref to lathe axis with the help of a carriage feed rod and lead screw. A wide range of attachments can be fitted on it to increase its utility. These are available in sizes to handle up to 1 m dia jobs and 1 to 4 m long.

iii) Turret Lathe: It is a production machine used to perform a large number of operations simultaneously. Several tools are set on a revolving turret to facilitate doing large number of operations on a job in minimum time. An index able square tool post is provided on the cross slide for mounting the turning and parting off tools.

The turret usually accommodates six tools for different operations like drilling counter sinking, reaming, tapping etc, which can be successively brought in to working positions by indexing the turret. Some special tool holders to perform simultaneous multi tool operations are also available. They are widely used be repetitive batch production.

iv) Capstan Lathe: It is similar to turret lathe and incorporate capstan slide which moves on an auxiliary slide and can be clamped in any position. It is best suited for fast production of small parts because of its light weight and short stroke of capstan slide.

v) Tool room Lathe: It is the modern engine lathe which is equipped with all necessary accessories for accurate tool room work. It is a geared head driven machine with considerable range in spindle speeds and feeds. It is suited for production of small tools, dies, gauges etc.

vi) Bench Lathe: It is a small lathe which can be mounted on the work bench for doing small precision and light jobs.

vii) Gap bed Lathe: In these lathes, a gap is provided on the bed near the head stock with a view to handle jobs having flanges or some other producing parts. Very often a removable portion is provided in the bed so that when not required, it can be inserted.

viii) Hollow Spindle Lathe: These lathes are provided with spindles having large through bores in order to facilitate turning the ends of long tubular work pieces. The long jobs are supported on a steady or some other out board support.

ix) Vertical turret Lathes: These have vertical orientation and are use for turning large components which can be conveniently mounted on the machine table. The turret head moves in two axes to enable turning, boring and facing.

x) Automatic Lathes: They are designed for all working and job handling movements of the complete manufacturing a job are done automatically. Operator participation is not required during the operation. In semi-automatic lathes, mounting and removal of work is done by the operator and all other operations are performed by the machine automatically.

xi) Special purpose Lathes: These are desired to suit a definite class of work and to perform a specific operation only. They prove to be more efficient and effective as compared to the common engine lathe.



Work Holders

1. CHUCKS:

It is the most important device for holding the work pieces, particularly of short length or larger diameter.

a) Independent or Four Jaw Chuck: It has four jaws and each jaw is independently actuated and adjusted by a key for holding the job. This type of chuck is used for irregular shapes, rough casting.

b) Three Jaw or Universal Chuck: In this all the three jaws move simultaneously by turning a key and thus the work piece may be automatically held in the centre of chuck-opening. It is used for holding round, hexagonal bar or other symmetrical work.

c) Collect Chuck: It is mostly used for holding bars of small sizes (below 63 mm) and is normally used where production work is required such on capstan lathe or automates.

d) Magnetic Chuck: They are either electrically operated or of permanent magnet type.

2. LATHE CENTRES:

Lathe centers are used for work holding during turning operation. A centre hole of particular depth and shape is made at each end of work piece. The lathe centers acts as the supports for the work piece and take up the thrust due to metal cutting. These are made of very hard materials to with stand wear and resists the deflection. The included angle of the centre is 60° for general purpose work and 75° for heavy work.

The various types of centers are:

- i. Ordinary centre, which is used for most general work.
- ii. Tipped centre, which contains a hard alloy tip brazed in to a steel shank.
- iii. Ball centre, which has a ball shape at the end of the centre, instead of a sharp point and is used to minimize the wear and strain on the ordinary centre while taper turning.
- iv. Half centre in which case less than half of the centre is ground away, thus facilitating facing of bar ends without removal of centers.
- v. Rotating dead centre is used in tail stock for supporting heavy work revolving at high speed.

3. COLLETTTS:

A collet is used for holding small semi finished or finished parts so that additional operations may be performed. It is a practical device for quickly and accurately chucking symmetrical work pieces. Collets are available in several shapes i.e. round, square and hexagonal holes to accommodate corresponding shapes of work pieces. The front portion is made conical and transverses slope is made in $\frac{3}{4}$ this length. The other end is threaded and was a key way to prevent the collet from turning in the collet sleeve

i) Draw in type: Which exerts the grip over the bar when it is drawn in.

ii) Push out type: Which exerts the grip over the bar when it is pushed out wards.

4. FACE PLATE:

It is a circular cast iron dies having a threaded hole at its centre so that it can be screwed to the treaded nose of the spindle. It consists of holes and slots by means of which the work can be secured to it. Both, nuts washers clamping plates and metallic packing pieces etc. are required for holding the work properly on a face plate.

5. ANGLE PLATE:

It is used for holding work in conjunction with a face plate. When the size or a shape of the work is such that it is not possible to mount the work directly on the face plate, the angle plate is secured to the face plate and the work is mounted on it.

6. LATHE MANDRELS:

Mandrels are a solid shaft or spindle used for holding bored parts for machining their outside surface on lathe. The mandrel is fitted in to the hole tightly and supports the job during machining of the outer surface. Mainly used for small jobs as bigger jobs will rotate over the mandrels. The solid or plain mandrel is ground to have a shape and a standard taper of 0.5 mm per meter is provided. The milled flat portions at the ends enable the screw of the dog to have a firm grip. Both the ends are made to have centres. The above taper facilitates an easy fitting of the mandrel in to the job hole and also allows for a little variation in the hole dimensions.

The collar mandrel enables a considerable reduction in weight. It is normally used for job above 100 mm dia. The stepped mandrel facilitates use of the same mandrel for various jobs having different size of holes which correspond to the step dimensions.

7. RESTS:

When a very long job is to be turned between centres on a lathe, due to its own weight it provides a springing action and carries a lot of bending movement which results in turning tool spoil and many even break. To avoid this, such jobs are always supported on an attachment known as steady rest or centre rest. This prevents the deflection of job and enables the operator to take heavy cuts.

8. JIGS AND FIXTURES:

They are used in conjunction with the face plate on a lathe for supporting and holding odd shaped and eccentric jobs during the operation. Their specific use is in mass production of identical parts. If a single item is to be made the cost of production of jigs or fixtures itself will be too high, prevent their use.

9. DRIVING PLATE:

It is cast circular disc having a projected Boss at its rear. The boss carries internal threads so that it can be screwed on to the spindle nose. It also carries a hole to accommodate a pin which engages with the tail of lathe dog or carrier when the job is held in the lathe dog or carrier. When a bent tail dog is used their pin is taken out and the bent portion of tail inserted in the hole, which serves the same purpose, or else the bent tail can be engaged in the slot made in the plate opposite to the pin hole.

BOX TOOLS

A large number of box tools are in application in capstan and turret lathe work. The common types are.

1. Those having V- shaped steadies.
2. Those having Roller steadies.

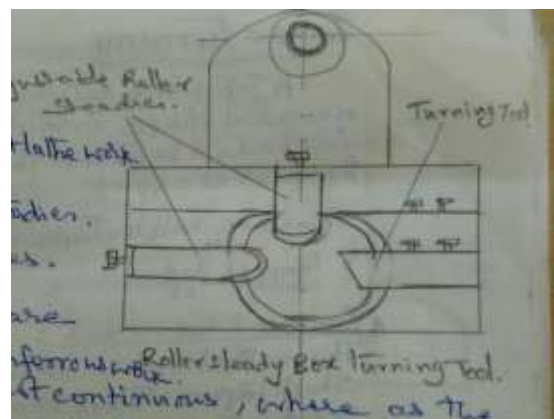

V-shapes steadies are mainly used for brass and nonferrous work. Where chips produced are not continuous, whereas the roller steadies is mainly used for steel work, where

continuous chips are produced. Except difference in the types of steadies, the rest of the mechanical features are same in both types of box tools.

Roller-steady box turning tool consists of a strong body, fitted with two adjustable slides, which carry hardened roller each. By moving the slides, the rollers can be adjusted at any desired distance from the centre of the work to act as travelling steadies during the operation. a single cutting tool is mounted in front of the attachment. In case of heavier type of such tools a supporting bush is fitted at the top to accommodate the pilot bar. This bush can be fitted either in front or back of the body according to the requirement. It is unavoidable when very heavy cuts are to be taken, to prevent vibrations.

The rollers, apart from acting as steadies, provide a burnishing action on the machined surface to give fine finish. The use of these tools some time enables the job to be finished in a single cut only. They facilitate the application of very high speeds.

Some imported designs of box tools take use of ball bearings as steadies in place of the rollers. These tools are normally of V-shape. One arm of these carries the shank and other opposite to it, the ball bearing, which is concentric with the shank. A bush is fitted in the bearing, which is a sliding fit on the bar to be turned. The bush and inner race of the bearing rotate with the bar as the tool is moved forward. The tool is fitted inside the 'V' construction to act radically on the job.

Taper Turning

A job which decreases in diameter gradually so that assumes a conical shape is said to be tapered. Taper angle is the angle included between the tapering sides of the job when extended to meet at a point.

$$\text{Tangent of half the taper angle} = \frac{D-d}{2l}$$

$$\tan\left(\frac{\alpha}{2}\right) = \frac{D-d}{2l}$$

$$\frac{\alpha}{2} = \tan^{-1}\left(\frac{D-d}{2l}\right)$$

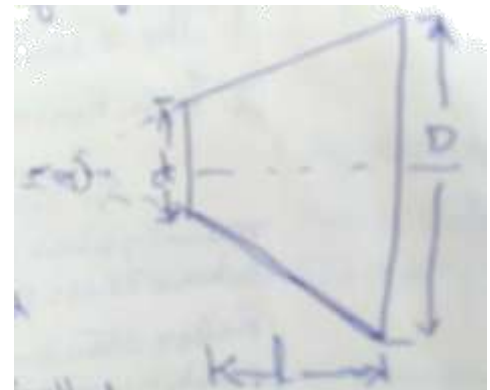

1. Compound Rest Method:

This method is used for turning steep and short tapers. There is a circular base graduated in degrees which can be swiveled at any angle from the centre line of the lathe centers.

While turning a taper, the base of compound rest is swiveled through an angle equal to the half of the taper angle. In this case, feed of the tool is given with the compound rest feed handle. This method is used for internal tapers.

2. Tail Stock Set over Method:

This method is used for turning small tapers on long jobs is confined to external tapers only. In this case tail stock may be set over by loosening the nut of the clamping bolt. Then by means of set screws, provided on the both the front and rear sides of the tail stock,

the dead centre is shifted from the original position by a predetermined amount of set over. If the larger dia. of the tapered part is to be obtained on the tail stock side, the centre will be shifted away from the operator and if the same is to be obtained on the head stock side the dead centre should be shifted towards the operator. Graduations provided on the flat surface of the tail stock, facing the head stock help in adjusting the required set over. However in the absence of such graduations a steel rule can be used for this purpose.

The required amount of tail stock set over can be calculated as follows:

Set over = taper length \times sine of half the taper angle

$$\frac{D-d}{l} = \sin \frac{\alpha}{2}$$

Where D = Larger dia.

d = Smaller dia.

l = Length of taper.

When a part of length of job is to be given taper

$$\text{The tail stock set over} = \left(\frac{D-d}{2} \right) \times \frac{\text{Total length of job}}{\text{Taper Length}}$$



Taper Turning by form or Broad Nose Tool:

Very sharp tapers can easily be turned with a form or broad nose tool in which the cutting edge of the tool is ground to contain the half taper angle α . However use of this tool will cause a lot of chatter and vibrations because the full cutting edge of tool is involved in cutting. Therefore this method of taper turning is confined to very short tapers of length max 20 mm. However with very heavy and rigid type of lathes their limit may go up as well.

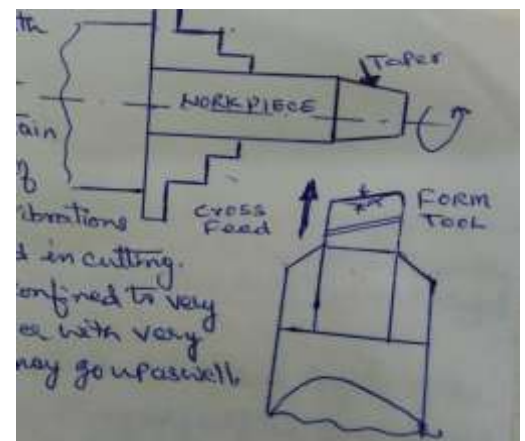

Taper turning attachment:

This attachment is confined to give external tapers only. It is bolted on the back of the lathe and has a guide bar which may be set at the desired angle of taper. As the carriage moves along the lathe bed length, a slide over the bar causes the tool to move in and out according to the setting of the bar. i.e. the taper setting of the bar is duplicated on the work. The main advantage of this system is that the lathe centers are kept in alignment, and the same taper may be turned on various pieces, even though they vary in length.

Advantages of using taper turning attachment:

1. Its setting is very easy and can be done very quickly.
2. Its use does not call for too much of skill on the part of the operator.
3. Accurate tapers can be readily obtained in single setting.
4. Normal set up and alignment of lathe and its main parts is not disturbed during the operation.
5. It is equally suitable for external and internal tapers.
6. It gives better surface finish and increased rate of production because longitudinal power feeds can easily be employed.

In some taper turning attachments instead of graduations in degrees, carries divisions in millimeters. In such cases it is required to find out, the no. of mm divisions through which the guide plate should be swiveled. These divisions can be found out from the formula.

$$M = \frac{D-d}{2} \times C$$

M = Required no. of mm divisions.

D = Larger dia.

d = Smaller dia.

L = Length of Taper.

C = Half the total length of guide plate in mm

Thread Cutting On Lathe

Internal and external threads are cut either with the help of a threading tool or with the help of tap and die respectively. While cutting threads with the help of a tool, the following requirement are fulfilled.

1. There should be a certain relation between the job revolutions and the revolutions of the lead screw to control the linear movement of the tool parallel to the job when the half nut is engaged with the lead screw.
2. The tool should be ground to the proper shape or profile of the thread to be cut. i.e. the tip or cutting edge of the tool should have an included angle corresponding to the included angle of the particular type of thread to be produced.

Irrespective of the shapes and sizes the common factor in all the threads is they are formed on the principle of helix and have a specified longitudinal movement of the cutting tool as the work revolves.

Both external and internal threads can be cut on the lathe. For both of these, the main requirement is to have a proper system of gearing between the lathe spindle and the lead screw so as to establish the required ratio of speeds between the two. For this some lathes are provided with quick-change gear box which provides required speed ratio quickly. This is done by simply shifting the position of the gear change lever. Such gear boxes are made to have a no. of gears inside them, mounted on two or three or more shafts and the different combinations of these gears provide different speed ratios. These combinations are obtained by shifting the gear change

lever to different positions. A chart is provided on the gear box which carries the complete information of speed and recommended feed corresponding to a particular position of the said lever.

In the absence of such gear box, the change gears, provided at the left hand side of the head stock are used to obtain the said ratio of speeds.

The chief elements of all the screw threads are:

- 1. Pitch (P):** It is the distance from the one point on one thread to the corresponding point on the adjacent thread. This distance is measured parallel to the axis of the job and is expressed in mms in metric threads and inches for other threads.
- 2. Major Diameter (D):** it is the largest diameter of a screwed part, measured at right angle to the axis of the piece.
- 3. Minor Diameter (D):** It is the smallest diameter of the screwed part measured normal to the axis of the piece.
- 4. Pitch Diameter (Pa):** For cylindrical screw parts this dimensions represents the diameter of the imaginary cylinder of which the surface will intersect the threads at such points, where the width of the threads is equal to the adjacent width of spaces between them.

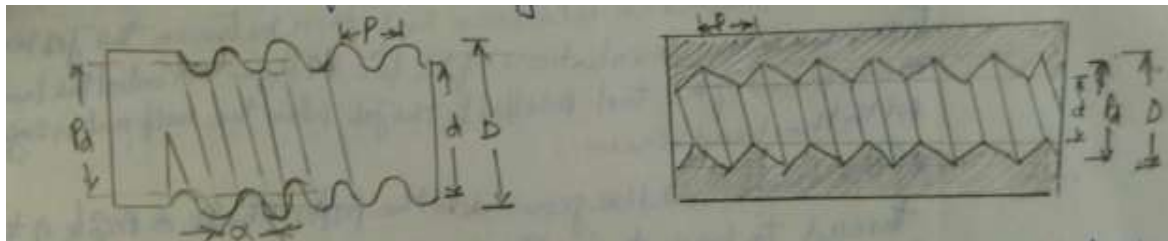

- 5. Depth of threads (t):** It is the distance, measured normal to the axis of the part, between the crest and root of the thread. Mathematically, it can be expressed as $t = \frac{D-d}{2}$

- 6. Thread angle (α):** It is the total included angle between the flanks of a thread or two adjacent flanks of two threads.

Right And Left – Hand Threads

When we look at a screwed part in a direction normal to its axis its threads will be found sloping downwards from top, either from left to right or from right to left. The former case represents the right handed threads and the latter left-hand threads.

A similar distinction can be observed and the hand of threads reckoned readily by observing the direction of movement when one member, out of the two mating screwed components is rotated. Hold a bolt in your left hand and try to screw on a nut on the same way by your right hand. Note the direction of rotating of the nut and its corresponding axial movement. If the nut advances axially when rotated in a clock wise direction it indicates right hand threads.

If this advancement is attained by rotating the nut in an anti clock wise direction, presence of left-hand threads is indicated. Right hand threads are most commonly employed in engineering practice.

START OF THREADS:

It is the no. of separate threads grooves running parallel to each other along the surface of the screwed part. The threads can be single or multiple starts. In case of single start, the thread is cut with only one thread groove all along its length. When the threads are cut with two, three or more separate thread grooves, each having same dimensions and being equip distance from one another, they are known as double, triple or multiple starts respectively. The advancement for the same amount of rotation of the screw part as compared to the single start threads. If the pitch in both cases remains the same, the axial advancement for the same amount of rotation will become as many times of the single start as the no. of start of the threads. The axial advancement in one rotation of the screwed part is known as lead of the threads or screw. It will obviously, be the distance measured parallel to the axis, between two corresponding points on the same thread. Pitch in the case of multiple starts

$$\text{threads} = \frac{\text{lead}}{\text{no.of starts}}$$
 i.e. the pitch will be equal to the lead in case of single start threads.

Lathe setting for screw cutting:

When the lathe is not equipped with a quick change gearbox, a suitable set of gears have to be fondant and mounted at the proper position for cutting the threads of different pitches. Setting up of lathe for such work includes proper holding of the job, concentric with the lathe centers, setting of tool at proper height and mounting of the calculated change gears at proper location.

For cutting threads it is necessary that for every revolution of the spindle or the work, the tool should move parallel to the axis of the job by a distance equal to the lead of the longitudinal feed of the tool and the speed of the spindle. The desired ratio is obtained with the help of lead screw by connecting it to the spindle through a train of gears.

The speed of the lead screw will be as many times lower than that of spindle as its pitch is greater than that of the screw to be cut.

To affect the variant on in speeds, change gears are employed and the amount by which the speed of the lead screw should be higher or lower than that of the work is determined by gear ratio.

$$\text{Gearing ratio} = \frac{\text{Speed of the lead screw}}{\text{Speed of the work}}$$

The pitch of the screw to be cut and the pitch of the lead screw determines the gear ratio of speeds.

$$\begin{aligned} \text{Gearing ratio} &= \frac{\text{Pitch of the screw to be cut}}{\text{pitch of lead screw}} \\ &= \frac{\text{Lead of screw to be cut}}{\text{Lead of lead screw threads}} \\ &= \frac{\text{No.of teeth of driver(slide gear)}}{\text{No.of teeth of driven(lead screw gear)}} \end{aligned}$$

↓

Simple Gear train:

It consists of a driving gear (mounted on the stud), A driven gear (mounted on the lead screw), and one or two intermediate gears. The intermediate gears (idle gears) have no effect on the speed ratio but are used only

- i) to fill the gap between the driver and driven gears, and
- ii) to obtain desired direction of rotation of the screw.

Compound gear train:

It consists of two studs instead of one. The second stud is suitably mounted on the bracket or quadrant carrying the change gears. The first driver A is mounted on the first stud, which meshes with the first driven B on the second stud. The second driver C is also mounted on the second stud and it meshes with the second driven D mounted on the lead screw. Such gear train is employed when the obtained gear ratio is such that it is not possible to arrange a simple gear train out of the given set of gear trains. It is not possible to arrange a simple gear train out of the given set of gear trains.

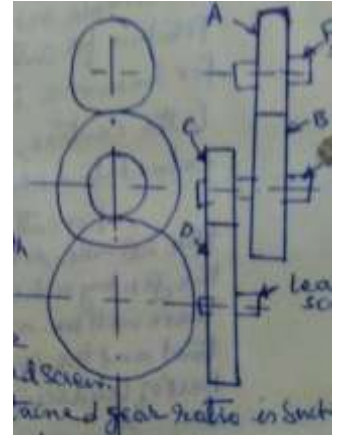
**Cutting Metric threads on English standard Lead Screw or Vice-Versa:**

When it is required to cut metric threads on a lathe having British standard lead screw i.e. pitch in inches. The relation for conversion

$$\frac{\text{Driver}}{\text{Driven}} = \frac{5}{127} \times \frac{\text{Lead of the screw to be cut in mm}}{\text{Lead of the threads on lead screw in inches}}$$

In case of reverse requirement i.e. when threads of British standard pitch are to be cut on the lathe having lead screw of metric pitch.

$$\frac{\text{Driver}}{\text{Driven}} = \frac{127}{5} \times \frac{\text{Lead of the screw to be cut in inches}}{\text{Lead of the threads on lead screw in mm}}$$

$$\frac{5}{127} = \frac{1}{25.4} \quad \text{or} \quad \frac{127}{5} = 25.4 \quad \text{is the multiplied ratio for conversion from}$$

British standard to metric and vice-versa.

Setting Tools for Threading:

In cutting threads, the cutting tools should be carefully set exactly at the height of the centers and normal to the axis of the work. If it is incorrectly set, the thread angle will not be correct and the flanks formed will not be proper. This setting is essential both for external and internal threads. A centre gauge is always used for setting the threading tool correctly.

Feeding the tool in thread cutting:

Two methods are commonly used for feeding the tool in thread cutting. In one case, the tool is set normal to the axis of the work and is fed straight in to the job. Once a cut is complete, the tool is withdrawn from the formed groove, the carriage returned to the starting

position and then the tool is fed forward for the next cut. The graduated dial provided on the cross feed screw helps in adjusting the required depth of each cut. The operation is repeated till full depth thread is obtained. In this case, the tool cuts the threads uniformly in each successive cut as both of its sides and its tip do the cutting. If this method is used for cutting coarse threads, the amount of material removed in the form of chips will be too much and it may ultimately jamming the tool and the flanks of the threads will be rough. It is advisable to confine its use only to finishing cuts on coarse threads. However it can be safely used for threads having below 2 mm pitch.

The second method is to feed the tool at any angle to the axis of the work. This angle is half of the total included angle of the thread. The tool is set as usual and required inclination is obtained by swiveling the compound rest to this angle. After every cut the tool is withdrawn by means of cross slide and then set for the next cut. In this case most of the cutting is done by the left edge and tip of the tool.

When threading is to be done large scale, the cutting tool will be provided with top rake angle for easy flow of chips on the tool face and “digging-in” tenderly of the tool is required.

Providing Under Cut:

Under cuts are necessary when cutting threads on stepped work. When the job has two different diameters and the threads are to be cut on smaller dia. it is essential to provide an undercut where two steps meet. It allows for the over run of the tool after one cut is over. In the absence of this undercut there is always a likely hood of the tool running in to the larger dia. after finishing the cut. This will lead to tool to dig which result is riding of the job over tool, bending of job, breaking of job and breaking of tool.

Thread Catching:

The complete depth of the thread can't be obtained in a single cut. Several cuts have to be taken, one after the other, till the required depth is obtained. For this, the tool has to be withdrawn from the thread groove after completing each cut and then brought to the starting position. Then we have to use some suitable method to take the tool follow the previously cut thread groove. In case it does not follow this path, the threads will be spoiled. The process of engaging the tool with the some groove in all the cuts is called thread catching or thread chasing. The following methods can be used for returning the tool to the starting position.

1. After a cut is over the tool is abruptly withdrawn and the machine stopped. The carriage is disengaged from the lead screw by disengaging the half nut and then brought to the starting point by hand. This is usually done in case of long threaded length.
2. When a very short length is to be threaded an alternate method is that, at the end of the cut we do not disengage the carriage from the lead screw. At the end of the cut the tool is withdrawn as usual and the machine stopped. Then the carriage is brought back to its starting position by reversing the direction of rotation of the lead screw. This method is very advantageously used for threading blind holes or for cutting such threads of which the pitch does not allow the use of chasing dial also. Since the carriage and lead screw are never disengaged, the tool automatically follows the previous path.

Correct engagement of the tool with the previously cut thread groove is a must for cutting the threads successfully.

Collect Chuck

It can be used with equal advantage on a centre lathe, capstan lathe or turret lathe for producing items from bar stock. It consists of the main body having a tapered inside surface which corresponds to the outside tapered surface of collet. A disc is incorporated in the chuck which carries inside threads to receive the rear threaded end of the collet on the outside surface of the disc, teeth are cut to form a bevel wheel which meshes with the bevel pinion, operated by hand by means of a key. Usually an adapter bush is fitted to the rear side of the chuck which carries internal threads. The assembly is then screwed on to the nose of the lathe spindle.

In operation, when the key is rotated, the disc rotates and in doing so, it either draws in or pushes out the collet, depending upon the direction of its rotation. When the collet is drawn in its split body in pressed against the tapered inside surface of the chuck, making a firm grip over the bar. When the collet is pushed out, the pressure on its body relieved and it opens out, releasing the grip on bar, which can be then fed forward.

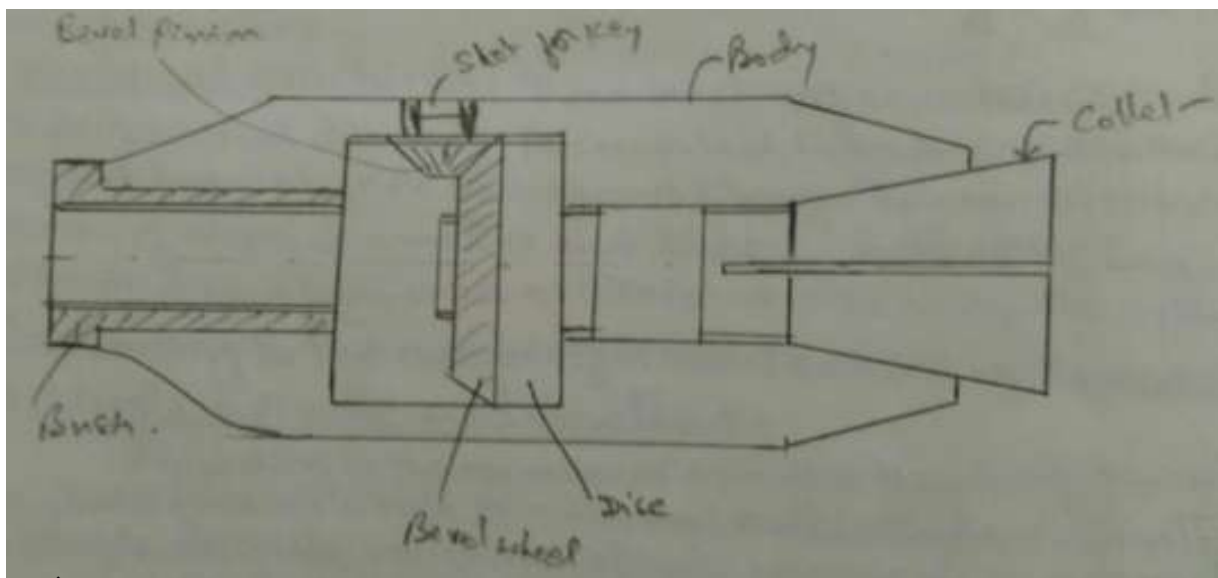

Automatic Lathes

Automatic lathes are best suited for production of identical parts on mass scale. They require the application of large number of tools. Once they are properly set, they produce the components at 3 times the rate of the turret lathe of same capacity.

Classification of Automatic Lathes:

Classified according to the type of stock material they use, the operations performed on them, principle of operation and number and position of spindles etc. The main classifications are:

1. According to the type of stock material used:

- a) Bar Automatics: The machines designed to produce various components using bar or pipe stock are known as bar automatics.
- b) Chucking Machines: These machines are used for machining separate blanks like forgings and castings etc and are also known as magazine loaded automatics.

2. According to the direction of the axis of the Machine Spindle:

- a) Horizontal Machines: This classification is according to the arrangement of spindles. These machines have their spindles in a horizontal direction and are used for machining long job of small diameters.
- b) Vertical Machines: These machines have their spindles set in a vertical direction. As compared to the horizontal machines, they are heavier, more sturdy and strong. They can accommodate blanks of larger diameters but shorter in length. They occupy less floor area as compared to the horizontal lathes.

3. According to the number of spindles carried by the Machine:

a) Single Spindle automatic: According to the no. of spindles they carry, the machines are classified as single spindle and multi spindles automatics. The single spindle machines are classified as single spindle machines operate on a single component at a time and include some cutting off machines and Swiss type automatic screw machines etc. The automatic cutting off machine is designed to produce short components, requiring turning, forming, drilling, threading, cutting off etc.

Two cross-slides are provided, which are operated by means of cams mounted on a cam shaft. A longitudinal slide is also mounted to carry tools for drilling, remaining, threading etc. All the operations are performed automatically.

The Swiss type automatically screw machines are used for machining slender parts of small diameter. They have a capacity to machine components of 2 to 25 mm dia. they differ from the above machine in that the longitudinal feed are obtained by moving the headstock with the bar instead of tools.

Automatic screw machine is fully automatic bar type turret lathe. They are used for manufacturing screw, both and pins etc from the bar stock. Ten different tools can be mounted at a time. The collet, bar feed mechanism, cross slide and turret slides etc are controlled and operated automatically.

b) Multi-spindle automatics: They are the improved types of single of spindle automatics. They are made to have 2 to 8 spindles, but 4 and 6 spindles are commonly used. The spindles are arranged in a carrier which is periodically indexed from position. The indexing takes place through 90° or 60° , depending upon whether there are 4 or 6 spindles. A gear is centrally mounted in the carrier which drives all the spindles, which are free to rotate in the carrier. This gear rotates independent of carrier. Out of all the positions, one position of the bar forms, cutting off positions, where the finished component in cut off and the bar fed forward up to the stop for the neat operation to be performed at the following position station. At each station(position) the work is machined by tools from two sides, i.e. the cross slide and the main or longitudinal slide. The spindles rotate at constant speed in all the positions.

Operating parts of the machine are controlled by means of cams, mounted on a cam shaft. The rate of production increases with multi spindle machines but the machining accuracy of single spindle automatic lathe is much higher.

In automatic machines, cams play the important role and they operate various tool slides, turret and working features of automatic machines. The cams may be made from circular discs or segmental form mounted on circular drums.

LATHE BED

The bed of the lathe acts as the base on which different fixed and operating parts of the lathe are mounted. It provides for location of fixed parts and controlled movement of the operating part(carriage). It has to withstand the various forces during the cutting tool operation. It must be very rigid and robust construction.

Lathe beds are made as single piece casting of semi-steel (i.e. toughened cast Iron) with the addition of small quantity of steel scrap to the cast Iron during melting. Cast Iron facilitates an easy sliding action & high vibration damping quality. In case of large machines the bed may be made two or more pieces, bolted together. Bed castings usually made to have a box section with cross ribs.

During solidification of the casting, distortion takes place due to cooling stresses. To avoid this natural seasoning called ageing is done. For this the bed castings are rough machined to the required size for final assembly accurately and finely finished. The common bed casting are fine grained with a hardness of $200 \pm 10\%$ BHN.

The additional steps taken to improve the wear resistance are:

1. Chilling of Castings.
2. Increasing the hardness of the wearing surfaces by flame hardening.
3. Super imposing separately hardened steel slide ways and prismatic (Inverted 'V') ways over the top of the bed casting.

The prismatic ways are preferred over flat ways as their construction totally disallows the entry of chips and dirt etc between the saddle and bed and thus preventing scratching. They provide very efficient guiding surfaces and the wear of the bed does not have any appreciable effect on the overall alignment to the lathe. In most cases the combination of the flat and prismatic shapes of bed ways are adopted. The flat ways acts as supports i.e. taking max load and stress and prismatic shapes act as guide ways. Tail stock is usually guided along the bed way by a combination of one prismatic and one flat way.

Proper leveling of the bed during installation and afterward is very important as this will affect the accuracy of the work very seriously. Therefore the bed should be tested for level both length wise as well as cross wise.

Head Stock:

The headstock serves as housing for the driving pulleys and back gears, provides bearing for the machine spindle and keeps alignment with bed.

It consists of the following main parts:

1. Cone pulley
2. Back gears and back gear lever
3. Main spindle or Head stock spindle
4. Live Centre
5. Feed reverse lever

Need for change of speed

There are several reasons due to which different spindle speeds are needed, because the work piece has to be rotated at different speeds under different machining conditions. The main parameters are

- 1. Work material:** Harder and tougher materials need slower speeds while softer materials are machined at faster speeds.
- 2. Cutting tool material:** The harder the cutting tool material the higher is the cutting speed, to take full advantage of higher hot hardness
- 3. Types of operation:** Operations like external and internal threading by means of single point tools, tapping, dicing, remaining etc on lathe need much slower speeds than many other operations like turning, drilling boring, facing, under-cutting etc.
- 4. Work piece Size:** Larger the dia. of work piece to be turned the slower is spindle speed required and smaller the work dia. the higher rotating speed.
- 5. Surface Finish:** Rough machining, where the main requirement is to remove maximum amount of material, needs a deeper cut and slower speed. Against this in finish machining the depth of cut is less and a higher speed used.
- 6. Cutting Fluid:** Use of proper cutting fluid, depending upon the cutting tool and work piece materials and other parameters, facilitates the use of higher cutting speeds and thus increased rate of production and reduction in machining time.
- 7. Rigidity of Machine Tool:** A rigid machine tool in perfect running condition enables use of higher spindle speeds.

TOOL – LAYOUT (For Turret & Capstan Lathes)

Tools for Capstan and Turret Lathe are similar in construction to those of centre lathe tools, except material. The tools used are made of H.S.S or Tungsten Carbide because the machines are more rigid and also operated at higher cutting speeds. The tools mounted on cross slide are used for turning, facing, necking, parting etc, and those mounted on the Turret head are used for drilling, boring remaining etc.

The tool layout for a job constitutes the pre-determined plan for machining operations of a particular component. The layout independent upon the no. of pieces to be manufactured i.e. lot size. As a general rule standard tools should be used as much possible and also for small batcher of work, the layout should be simple. For large quantities and long run special tools should be used as they minimize machining time and retain their cutting qualities for the maximum period. The accuracy and cost of component largely depends upon the tool layout.

For preparation of tool layout, it is necessary to have the finished drawings of the part to be machined and if it is a forging or casting, the forged or cast blank will determine, how much machining has to be done on various faces.

After preliminary list-giving the order of operations has been decided upon with details as the tools required, a tool layout to the scale is prepared on the tracing paper by super-imposing the layout of the machine capacity chart, drawn to the same scale with the component in position. A simple preliminary trial is conducted on the drawing board before it is put on the machine.

Ex: Tool Layout for front wheel Axle.

Tool layout shows types of tools required and the sequence in which they are to be used. While preparing the tool layout the capacity chart of the machine showing the capabilities should not be lost sight of. It also ensures that tool movements and turret indexing etc clear the various machine parts. Machining time can be established by listing the operations required systematically in the form of tool – layout.

To machine the front wheel axle from 18 mm steel bar, the following operations required.

1. Feed out the bar
2. Turn 14.5 mm dia. with tool box
3. Turn 13.5 mm dia. with the tool box
4. Round end with roller steady end tool
5. Centre with centre tool
6. Cut thread with Coventry die
7. Form 17 mm diameter and chamfer with tool in square turret
8. Part off with stepped cut off tool in the rear tool post

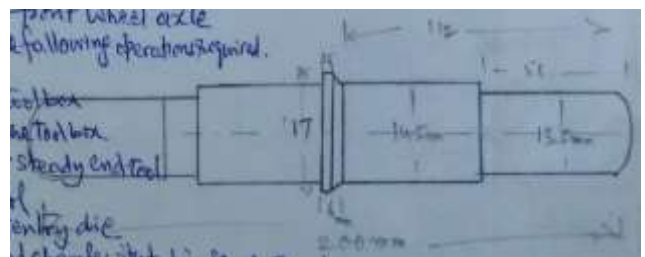

Tool Posts

Tool posts are the device used on various machines for holding the tools in position and providing a rigid support to them during the operation.

American type single tool post is used for holding a single tool holder or a solid forged tool only. It is commonly used in light work. It consists of a vertical body having a slot to accommodate the tool shank and a flange at its bottom. The collar carries a spherical groove in which a rocker is placed. This rocker can be tilted to adjust the height of the cutting edge of the tool.

Open side tool post is a better form of a single tool post. The main clamping bolt is used for securing the tool post and the adjusting screws for gripping the tool in position. Height of the tool is adjusted by using flat packing pieces under the tool. This form of tool post used as rear tool post on lathes.

Another useful form of tool Post usually employed on heavy duty lathes. It is provided with 4 bolts, each carrying a coiled spring. Two tools can be simultaneously mounted on it. The tools are held between the bases and clamping bars and gripped firmly by tightening the bolts. The springs help in keeping the bars in position when the tools have been withdrawn.

A square tool post vastly used in mass production. It can accommodate 4 tools at a time. It is also called a turret tool post. It facilitates mounting of 4 different tools prior to starting the operation and bringing them to the desired position, one after the other, by rotating the handle. Such arrangement is an asset and a vital necessity in repetition work, because it saves a lot of time in tool setting.

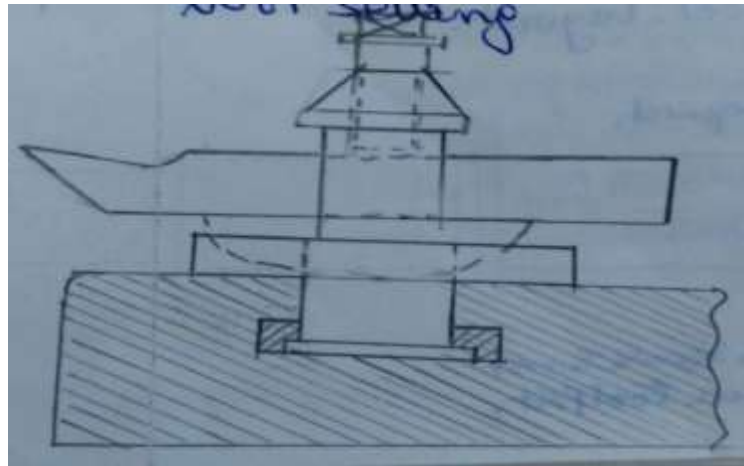

LAYOUT OF SPINDLE SPEEDS

The following factors have to be decided for designing any stepped drive:

- a) Max. output RPM (N_{max})
- b) Min. output RPM (N_{min})
- c) No. of steps of the transference (n)
- d) No. of sub-divisions of steps
- e) No. of stages in which steps are to be mounted

In multipurpose machines the selection of speeds is very complex, as correct speed depends upon various factors i.e. the proper toes of job material, shape of the cutting tools, wear resistance of tool material, type of operation to be performed and the process capability of the machine. However in single purpose machine the selection of particular speed depends upon the machining characteristics of that process only. In case of cylindrical work piece, the cutting speed V_c is related to the diameter of the work (D) and the spindle speed (N) by the relation,

$$V_c = \frac{\pi DN}{1000} \quad \text{Spindle speed } N = \frac{1000V}{\pi D} \quad \text{_____ (1)}$$

From the above equation the min. speed of the spindle in depend upon the max. dia of work that can be accommodated in the machine. Also depend upon the min. speed required for screw cutting and tapping.

Again from the above equation the max. Speed (N_{max}) depend upon

- i) The greatest possible cutting speed (V_c) and
- ii) When the diameter is minimum possible.

For design purpose the value of minimum diameter is taken as $= (\eta/8)$ where η is the height of the centers above the bed.

From the above equation it is also obvious that for constant value of V_c as the diameter increases, the speed N should decrease and vice-versa. The output spindle speeds generally form a series which may be in arithmetical progression (A.P), Geometrical Progression (G.P) or Logarithmic Progression (L.P). It is now obvious that for constant N the relation between V_c and D is a straight line. Graphically, the relation between V_c , D and N is represented by Ray diagram.

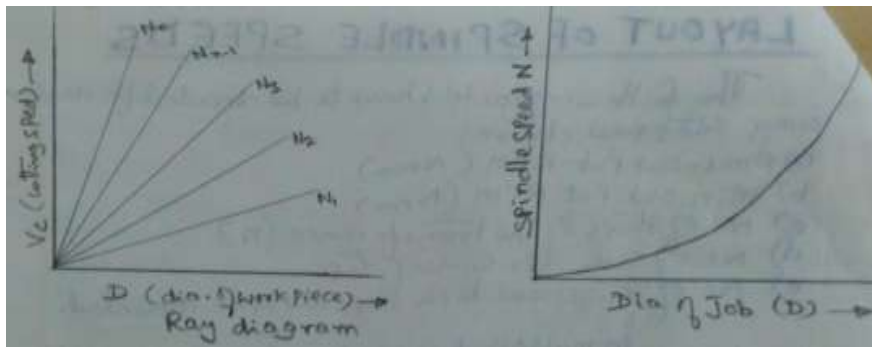

Let us study the most suited series in all respects for machine tools. Let us assume that a bar in to be machined on a lathe and its diameter D varies from some min.dia to some max.dia. Assuming V_c to be constant, the variant on of spindle speed with change in job diameter is observed. Initially as the dia of job increases the speed change is not much, but after words, even for small changes in diameter the spindle speed changes rapidly. This condition is fulfilled by G.P. series. Whereas A.P. series follows a straight line an can't fulfill this requirement. This G.P. series is preferred as it can provide more number of ranges of speed at lower range.

Kinematic Advantages of Geometric Progression:

The various speeds in some progression in several steps be $N_1, N_2, \dots, N_{n-1}, V_c$. Corresponding to certain dia D , the required RPM(N) for accurate cutting velocity(V_c) is not available.

We have select lower speed V_{p-1} . In that case

Loss of Speed = $V_c - V_{p-1}$

and percentage loss of speed = $\frac{V_c - V_{p-1}}{V_c} \times 100$
 $= \frac{\pi D N - \pi D N_{p-1}}{\pi D N} \times 100 = \left(1 - \frac{N_{p-1}}{N}\right) \times 100$

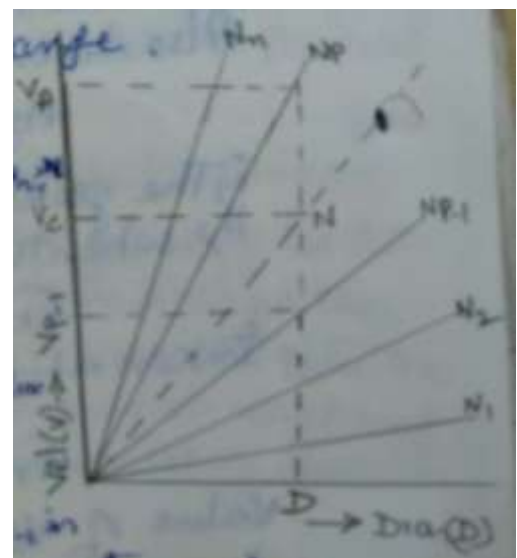

Max. Possible speed loss in between two steps N_p and

N_{p-1} is = $\left(1 - \frac{N_{p-1}}{N}\right) \times 100$. This loss should be constant for any two available ranges of speeds and for that $\frac{N_{p-1}}{N}$ should be a constant (Say = Q). This is possible if $\frac{N_{p-1}}{N} = Q$ or if it follows G.P. If N_{max} and N_{min} are max. and min rotational speeds and these are achieved in

steps then $\frac{N_{max}}{N_{min}} = \text{Range}$. Range Ratio \rightarrow 40-60 for lathes, 80-100 for capstan lathe, 40 for shapes Range Ratio(R) = Q^{n-1} or $Q = \frac{1}{n-1} \log_e R$ further max. Loss = $1 - \frac{1}{Q} = \frac{Q-1}{Q}$. 20-30 for

drilling machines 30-50 mille machines 1-10 grinders

for an efficiency of 50% $\frac{Q-1}{Q} = \frac{1}{2}$ or

$Q=2$, for steps less output $Q \rightarrow 1$ and loss of velocity in that case=0. Thus for G.P. the useful value of common ratio lies between 1 and 2 i.e. $1 < Q < 2$. Value of Q 1.12, 1.26, 1.41, 1.56 & 2
Automatic lathes 1-10.

TOOL LAYOUT FOR AUTOMATIC LATHES

Tool layout is a definite schedule or sequence of different operations to be performed for producing a job and preparing a list and sequence of application of the tools to be used. The important points to be considered are

1. To minimize machining time, try to put as many tools to operate simultaneously. This can be done by over lapping the corresponding machining operators.
2. The job handling operations should also be over lapped with machining operations. This will reduce manufacturing time and increase rate of production.
3. Cutting tools should be planned that during the operation the cutting forces are counter balanced by one another. This will increase tool life and surface finish on the job.
4. If several tools are used separately for rough turning a surface. This will minimize un evenness of the surface.
5. In order to maintain perfect concentricity between external and internal surfaces of a part, these surfaces should be finish machined out the same station.
6. To have a better finished component, avoid over lapping of roughing and finishing operations.
7. In planning the drilling operations the following points taken care
 - a) Centre drill should always be used for spot drilling (centering) before hole is drilled.
 - b) Deep holes should not be drilled continuously, it should be taken out of the hole many times during the operation in order to break the chips and allow the drill to cool. This will improve tool life and give better finish.
 - c) When a hole of varying diameter is to be drilled, always use the drills in a descending order of their diameters. This will minimize total drilling time.
8. Cutting of deep grooves and pasting off should in variably be the last but one and last operations respectively.
9. The operations are planned in such a way that the machining time taken at each station is nearly the same and particularly in multi spindle automatics.
10. Extra ordinarily long single operation should be divided in too many small operations in order to meet the requirement of proceeding point q.

Exp: Producing a Circular Pin on a Capstan lathe from bar

stock The tooling layout for producing the above part is

Procedure:

1. Feed the bar against stop.
2. Rough turn the pin with roller steady box tool.
3. Finish turns the pin with roller steady box tool.
4. Chamfer the pin end.

5. Knurl with concentric knurling tool
6. Cutoff by using the parting off tool in the rear tool post.

Exp: Making a hex. Head bolt on a Capstan lathe from hexagonal bar stock

The tooling layout for producing the given bolt. The operations at station 4 and 5 can be done simultaneously

Procedure:

1. Feed the bar against stop.
2. Rough turn the bolt dia. with a roller steady box tool.
3. Finish turns the bolt dia. with a roller steady box tool.
4. Cut threads with self opening dia. head.
5. Face and from turn the head by the tools mounted on the front tool post.
6. Cutoff parting off tool held in the rear tool post.

UNIT-3

SHAPER

WORKING PRINCIPLE:

The job is rigidly held in a vice or clamped on a machine table. The tool is held in tool post mounted on the ram of the machine. The ram reciprocates to and fro and in doing so, makes the tool to cut the material in the forward stroke. No cutting of material takes place, during the return stroke of the ram. Hence it is called idle stroke. In case of draw-cut shaper, the cutting takes place in the return stroke and forward stroke is idle stroke. The job is given an indexed feed in a direction normal to the line of action of the cutting tool.

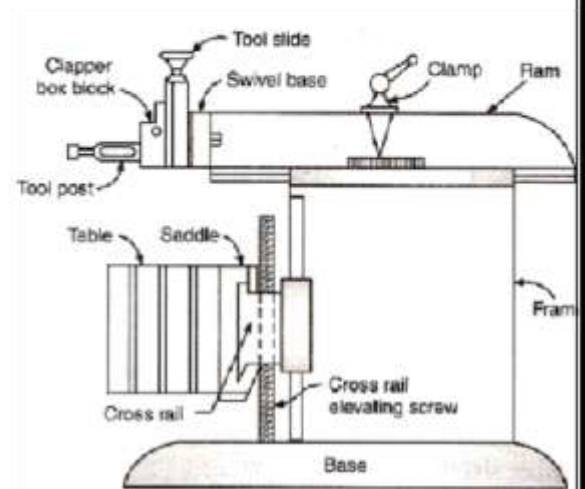

PRINCIPAL PARTS:

- 1. Base:** It is a heavy and robust cast iron body which acts as a support for all other parts of the machine, which are mounted over it.
- 2. Column:** It is a box type cast Iron body, mounted on the base and acts as housing for the operating mechanism of the machine, and the electricals. It also acts as a support for other parts of the machine such as cross rail and ram, etc. On its top it carries a machined ways, in which ram reciprocates and vertical guide ways at its front.
- 3. Cross-rail:** It is a heavy cast Iron construction, attached to the column at its front on the vertical guide ways. It carries two mechanisms, one for elevating the table and the other for across traverse of the table.
- 4. Table:** It is made of cast Iron and has a box type construction. It holds and supports the work during the operation and slides along the cross-rail to provide feed to the work. T-slots are provided on its top and sides for securing the work to it.
- 5. Ram:** It is also an Iron casting, semi circular in shape and provided with a ribbed construction inside for rigidity and strength. It carries the tool head and travels in dove tail guide ways to provide a straight line motion to the tool. It carries the mechanism for adjustment of ram position inside it.
- 6. Tool head:** It is the device to hold the tool. It can slide up and down and can be swung to a desired angle to set the tool at a desired position for the operation.
- 7. Vice:** It is a job holding device and is mounted on the table. It holds and supports the work during the operation. Alternatively, the job can be directly clamped to the machine table.

SIZE AND SPECIFICATIONS

The size of the shaper is determined by the maximum length of cut or stroke it can make. A standard shaper is usually capable of holding and machining a cube of the same dimensions as the length of stroke. The length of stroke is always the principal dimension, but a number of other details are also required to specify a shaper fully. Complete specifications of a 300 mm stroke shaper are as follows.

MACHINE TOOLS

III B.Tech I Sem (Mech)-R17

1. Length of stroke	300 mm
2. Max. Horizontal travel of table	350 mm
3. Max. Vertical travel of table	365 mm
4. Max. Distance from table to ram	12 mm
5. Max. Vertical travel of tool slide	117 mm
6. Length and width to table top	300 × 250 mm
7. Length and depth of table side	241 × 317 mm
8. Power of Motor	2/2 HP OR 1.5/1.5kw
9. No. of ram cycles per minimum	6
10. Range of ram cycle per minimum	21 to 22 mm
11. Tool box takes tool of size	16 × 22 mm
12. Max. Vice opening	152 mm
13. Approximate Weight	700 kg
14. Floor space	1350 × 790 mm

CLASSIFICATION OF SHAPERS

Shapers are classified in many ways, i.e. according to length of stroke, type of driving mechanism, direction of travel of ram, the type of work they do, the type of design of table etc. The main classification is as follows:

1. Standard Shaper: It consists of a plain table, may or may not have the vertical supports at its front. In some machines there is a provision for the table to swivel around horizontal axis, parallel to ram. This enables machining of inclined flat surfaces. Material is cut in the forward stroke of the tool and the return stroke is idle. It is also known as plain shaper.

2. Draw-cut Shaper: it is similar to standard shaper, but is comparatively much heavier and the metal cutting operation takes place during the return stroke of the ram i.e. in moving towards the column. Its heavy construction enables heavier cuts with less vibration.

3. Horizontal Shaper: It is a very popular shaper in which the ram and tool reciprocates in horizontal plane. Normally used to machine flat surfaces.

4. Universal Shaper: It is a horizontal type shaper but its table can be swung about a horizontal axis parallel to ram ways. The top of this table can be tilted about another horizontal axis which is normal to the former axis. If a swivel vice is fitted to this table the work can be rotated about three possible axes. Machining of surfaces can be taken up in different planes and the machine is very useful for tool- room work.

5. Vertical Shaper: This shaper has its ram reciprocating in a vertical direction. The table is of circular, rotary type. The ram of vertical shaper can be adjusted 10 on either side of vertical, enabling machining of inclined surfaces also.

6. Geared Shaper: This classification is according to the type of driving mechanism. This type of shaper carries a rake under its arm which is driven by super gear (pinion). This has become obsolete.

7. Crank Shaper: These shapers carry a crank and slotted link mechanism for the ram movement. Large no. of shapers uses this mechanism.

8. Hydraulic Shaper: In this hydraulic pressure is used for driving the ram. It is more efficient as it enables constant speed and force from the start to the end of the cut.

9. Contour Shaper: In this a standard shaper is fitted with an additional tracer mechanism, a template and a follower is used to reproduce the contours of the template. This facilitates machining of those shapes which would have been impossible on any other type of shaper.

10. Travelling head Shaper: It is a specially designed shaper for machining heavy and large work pieces which can't be held on the table. Such jobs are loaded on the base of the shaper or on the floor and then machined. In these machines, the ram is so designed that, in addition to reciprocation for machining, it also gets a cross movement to provide necessary feed.

SHAPER OPERATIONS

Several different shapes of jobs can be produced on shapers. The basic operations done on a shaper can be broadly classified as

1. Horizontal cutting. 2. Vertical cutting 3. Angular cutting. 4. Irregular cutting

1. Horizontal Cutting: It is the most common operation on shaping machine. In this the work is fed in a horizontal direction under the reciprocating tool and the surface produced is horizontal and flat.

2. Vertical Cutting: The tool is fed down wards in vertical cutting. This type of tool feed is commonly used in cutting grooves, key-ways, tongues, parting off and squaring ends and shoulders.

3. Angular Cutting: The angular cutting is employed for machining inclined surfaces, beveled surfaces and dove- tails etc. In this down feed of the tool is used.

4. Irregular Cutting: If an irregular surface is to be machined, the shapes marked on the side of the job. The preferable procedure for such machining is to first rough machine the surface to about 15 mm above the marked shape. Then bevel the edges at about 45° by means of a file and machine off the beveled portion. Thus the job is machined up to the marked shape. For machining such surfaces a combination of vertical hand feed to the tool and horizontal power cross feed to the table is to be used.

MACHINING TIME:

$$\text{Cutting speed (V}_1\text{)} = \frac{\text{Length of cutting stroke(L)}}{\text{Time taken in cutting stroke}} \quad (\text{V}_1 = \text{average cutting speed m/min})$$

$$\text{Cutting Time} = \frac{L}{v_1} \text{ min} \quad \text{Non Cutting Time} = \frac{L}{v_2} \text{ min} \quad (\text{V}_2 = \text{Average return speed m/min})$$

$$\text{Total time per cycle} = \text{Cutting time} + \text{Idle time} = \frac{L}{v_1} + \frac{L}{v_2} = \frac{L}{v_1} + k \times \frac{L}{v_1}$$

(Where k = Ratio of idle stroke time to cutting stroke time)

$$\text{Total time} = \frac{L}{v_1} + k \frac{L}{v_1} = \frac{L(1+k)}{v_1} \text{ minutes}$$

For shaping a work piece an allowance of about 5mm is left on either side of it

Shaping Width $B = \text{Width of work piece} + 2 \times \text{allowance}$

$$\text{No. of Cycles required}(\eta) = \frac{\text{Shaping Width}(B)}{\text{Feed per cycle}(f)} = \frac{B}{f} \quad (f = \text{feed per cycle in mm})$$

Machining time = no. of cycle

Machining time = no. of cycles \times Time required for each cycle

$$= \frac{B}{f} \times \frac{L(1+k)}{V_s} = \frac{L \times B(1+k)}{f \times V_s} \text{ min}$$

PLANING MACHINES

Planing is machining of large flat surfaces. These surfaces may be horizontal, vertical or inclined. The function of a planing machine is similar to that of a shaper except that the planer is basically designed to undertake machining of large and heavy jobs which are impracticable to be machined on shaper or milling machine etc. Planing machine is the most economical for machining large flat surfaces. Planing machine is differ from a shaper in that for machining, the work, loaded on the table, reciprocates past the stationery tool in a planer, where as in shaper the tool reciprocates past the stationery work.

WORKING PRINCIPLE:

It is almost a reverse case to that of a shaper. The work is rigidly held on the work table of the machine. The tool is held vertically in tool head mounted on the cross-rail. The work table, together with the job is made to reciprocate past the vertically head tool. The indexed feed, after each cut, is given to the tool during the idle stroke of the table.

PRINCIPAL PARTS:

1. Bed: It is a very large and heavy cast iron structure with cross ribs for additional strength and stiffness as it supports the whole structure of the machine over it. It is about two times longer than the table it carries over it. At its top it carries either v-ways or flat ways to support and guide the table. All the ways are straight, parallel and constantly lubricated with pressure lubrication at several points along the ways.

2. Table: it is made of Cast Iron with accurately machined top. It is a box type construction with ribs under it to make it strong to support heavy work over it. At its top, it carries longitudinal T-slots and holes to accommodate the clamping bolts and other devices to hold the work. Under the table, chip pockets are cast integral with it for collecting and removing the chips.

3. Housings or Columns: The columns are vertical members, situated on both sides in case of a double housing planer and on one side only in case of an open side planer. Inside them, they carry the different mechanisms for transmission of power to the upper parts of machine, from the main drive, viz. cross-rail elevating screws, vertical feed shaft and cross feed bar etc.

4. Cross-rail: It is a horizontal member of a heavy structure connecting the two vertical columns of the machine. It provides additional rigidity to the machine. By means of elevating screws it can be moved up and down along the ways on the columns. Clamps are provided to lock the cross-rail in any desired position along the columns. A suitable device is incorporated to ensure that the cross-rail is perfectly horizontal before clamping. The cross-rail is moved up or down uniformly on both ends, both the elevating screws are rotated simultaneously by horizontal shaft, mounted on the top of the machine through bevel gears. Ways are provided at the front of the cross-rail for the two vertical tool heads. Inside the rail are provided the feed rods for vertical power feed and cross feed to the tools. The rail is made sufficiently long, to project on both sides of columns, so that, one of the two tool

heads can be pushed out to one end. This will enable other tool head to travel freely cross-wise from one end of the table to the other, covering entire width of the job.

5. Tool Heads: The planer tool heads, both in construction and operation resembles the shaper tool heads. Four tool heads can be fitted in a planer and any or all of them can be used at a time. Two tool heads can be fitted in vertical position on the cross-rail and the other two on the vertical columns. Each column carries one side tool head.

The method of mounting is similar for all the tool heads. First the saddles are mounted on the horizontal ways of the cross-rail (for vertical tool heads) and vertical ways of the columns (for side tool heads) these saddles further carry machined ways at their front, on which tool heads are mounted. All the four tool heads work independently, simultaneously.

The tools heads on the cross-rail can travel horizontally, along the rail. They can also be raised or lowered by moving cross-rail up or down. The tools can be fed down wards by rotating the down feed screw. Similarly the side tool heads can move up and down along the vertical column ways. Their tools can be fed horizontally in to the job or at desired inclination. A swivel plate incorporated between the slide and saddle. This enables the tool head swivel through an angle of 70° on either side from its normal position. Both hand feeds and power feeds can be used, but power feeds are commonly used.

6. Controls: Various controls for starting, operating and stopping the various mechanisms, automatic cutting off speed and regulation and similar other functions are provided with in quick approach of the operator of the machine.

SPECIFICATIONS:

Planers are made in different sizes, the main specifications are

1. Horizontal distance between the two vertical columns or housings.
2. Vertical distance between the table top and the cross-rail when it is in top most position.
3. Maximum length of table travel or length of stroke.

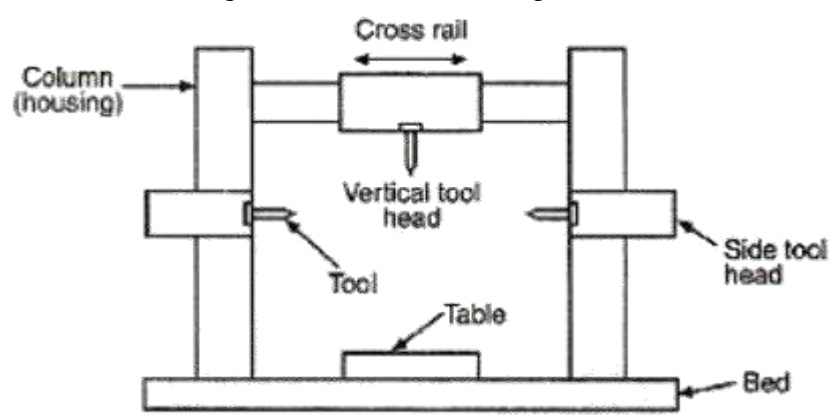

TYPES OF PLANERS:

A large variety of planers of different designs and sizes are available and they are broadly classified in to the following types:

1. Standard or Double housing planer
2. Open side planer
3. Planer Miller
4. Plate planer
5. Pit planer

6. Divided table planer, and
7. Plano-Guillotine shearing machine.

1. STANDARD OR DOUBLE HOUSING PLANER:

This is most commonly used type of planer. It consists of two vertical housings or columns, one on each side of bed. The housings carry vertical machined and scraped ways. The cross rail is fitted between the two housings and carries one or two vertical tool heads. The work table is mounted over the bed. Side tool heads are fitted on the vertical housings.

These machines are heavy duty type and have very rigid construction. They use high cutting speeds but the size of the work is limited to width table i.e. the horizontal distance between the two columns. Extremely large and heavy casting, like machine beds, tables, plates, slides of columns, it is possible to hold a number of work pieces in a series over the bed length and machine them together. This will effect in saving machining time. Because of four tool heads a number of surfaces can be machined simultaneously. Because of high rigidity of machine, robust design of cutting tools, heavier cuts can be taken, which leads to quikes metal removal and reduced machining time and hence to economical machining.

2. OPEN SIDE PLANER:

This type of planer consists of only one housing, situated vertically on one side of the bed and the other side is left open without any obstruction. The cross-rail is of cantilever type and is wholly supported on the single column. Only three tool heads can be used maximum. The other features are same as double housing planer.

The main advantage of an open side planer is its adoptability for machining components which are much wider than could pass between the housings.

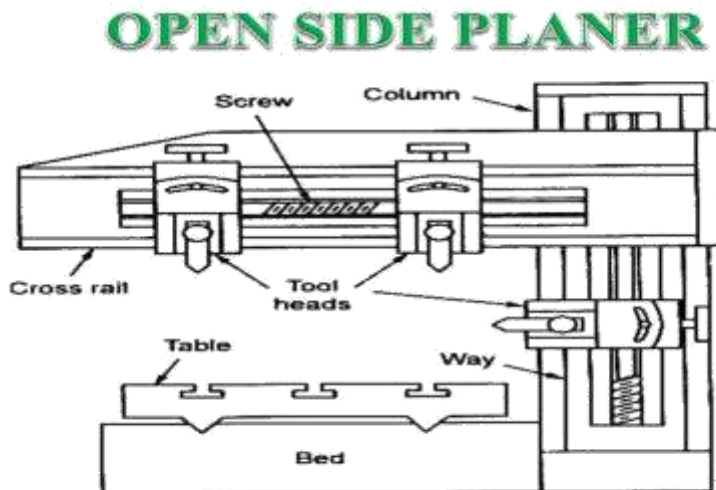

3. PLANER MILLER:

It is actually a combination of the two machines, and hence the name planer miller. It resembles a double housing planer but the conventional revolving cutters.

4. PLATE PLANER:

This is completely different from the conventional type both in construction and operation. The bed and the table of the plate planer are a fixed unit and the work is mounted on the table. The tool head is mounted on a movable carriage, which can travel longitudinally along the bed. The operator also stands on a flat form attached to the carriage and travels along it during machining. The work remains stationary while the tool moves to and fro. The

tool holder can hold one or more tools at a time and can also be tilted for machining slant surfaces. It is a single purpose machine for a special work. Ex: machining edges of boiler plates, ships plates, for pipe lines and for welding.

5. PIT PLANER:

This machine is specially designed for machining long, heavy and tall work, that can't be machined on the conventional type of planers. The job is mounted either on stationary table or on the floor inside a pit. The machine is provided with two short vertical housing which carry cross-rail. One or two tool heads are mounted on the cross rail and two side tool posts on the housings. This whole unit travels along the horizontal ways to and fro and thus the tool moves past the work for machining the surface. The horizontal and inclined surfaces of the work piece are machined on these planers.

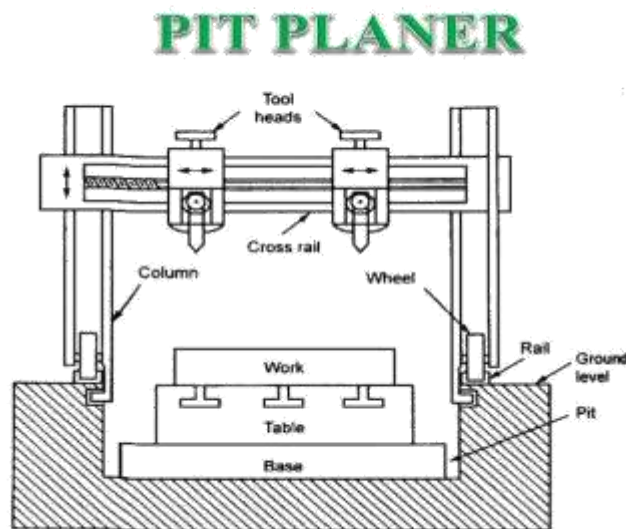

6. DIVIDED TABLE PLANER:

In this machine, the table is constructed in two or more parts which can be joined together to hold a very large work. Large part of total time, spent on machining a job, is spent in its proper setting because of the difficulty in handling the work due to its heavy weight. This machine with divided table is employed such that when the work on one table is being machined, the same is being simultaneously set up on the other table in readiness for replacing after the operation is over. Thus considerable setting time it saved.

7. PLANO-GUILLOTINE SHEARING MACHINE:

It is also a special purpose machine used for cutting and preparing ends of large plates. It is provided with a traversing cutter head which carries a rotary disc cutter instead of a single point tool. The standard cutter will always cut square with the surface. Other cutters can be fitted to cut to an angle. A swiveling type of head is also provided in order to produce angular cuts. The plate is sheared off in a single traverse of the cutter head. The machine, thus gives much higher output than the conventional planer.

DRIVING MECHANISMS:

Four different methods are employed for driving the table of a planer. They are as follows:

1. Crank drive: Similar to the one used for driving the ram of a shaper. It is however obsolete now.

2. Belt drive: In this the motor drives a counter shaft, which is turn, drives the main driving shaft through belts and a set of fast and loose pulleys. This shaft drives a pinion which meshes with a rack under the machine table.

3. Direct reversible drive: In this the reversible motor, through a set of reduction gears, drives the pinion which meshes with the rack provided under the machine table.

4. Hydraulic drive: it is quite similar to the one used for driving the ram of a shaper. More than one cylinder can be used for achieving different speeds.

What ever may be the methods of drive used for a planer table, it should essentially meet the following operating requirements:

- i. It should be long lasting and its control should be easy.
- ii. It should be capable of providing several quick and safe reversals of the table continuously without any chance of break down.
- iii. It should incorporate a mechanism for faster return of the table, accurately at the same point in each stroke, without any stroke or vibrations. The return speed of the table is supposed to be 3 to 4
- iv. It should provide a fairly wide range of variable speeds.
- v. It should not unduly vary, after being set, during cutting.
- vi. It should be possible to stop the running table suddenly. Whenever desired for any purpose, and restart it instantly.
- vii. It should incorporate a mechanism for speed reduction.

CUTTING SPEED, FEED AND DEPTH OF CUT:

Frequent variations in cutting speeds are not needed and it will be considered on account of the kind of cutting tool and material to be machined. Planer is used for machining heavy jobs and obviously heavier cuts are used, with the result uses much slower speeds than most of other machines. Suitable cutting speed is selected depending upon tool material and the work. Planer usually employ a cutting speed of 6 to 15 m/min and return speed 30 m/min. a cutting speed of 25 m/min and a return speed of 45m/min is obtained on hydraulic planers. The feed and depth of cut depends upon the material of the work, required surface finish and rigidity of the machine.

OPERATIOINS DONE ON PLANER:

A planer performs the same operations as performed by a shaper, with the main difference that the work pieces handled on a planer are longer and heavier than those machined on a shaper and also the surfaces machined on a planer are much larger and wider than those produced on a shaper. The common operations performed on a planer are:

1. Machining horizontal flat surfaces.
2. Machining vertical flat surfaces.
3. Machining angular surfaces, including dove -tails.
4. Machining different types of slots and grooves.
5. Machining curved surfaces.
6. Machining along pre marked contours.

COMPARISION BETWEEN PLANER AND SHAPER

S.No	PLANER	SHAPER
1.	It is heavier, more rigid and costlier m/c.	Comparatively lighter and cheap m/c.
2.	It requires more floor area.	Less floor area.
3.	It is used for machining large flat surfaces horizontal. Vertical and inclined.	It is also used for the same purposes but for relatively smaller surfaces.

4.	Cutting takes place by reciprocating the work under the tool.	Cutting takes places by moving the cutting tool over the job.
5.	Indexed feed is given to tool during the idle stroke of the work table.	Indexed feed is given to the work during the idle stroke of the ram.
6.	Heavier cuts and coarse feed can be used.	Very heavy cuts and coarse feeds can't be used.
7.	Four tools can be used simultaneously facilitating a faster rate of production.	Only one tool can be used on a shaper.
8.	Because of its larger stroke length and table size, number of jobs can be held in series and machined in single setting.	This is not possible on a shaper.
9.	The tools used are longer, heavier and stronger.	Tools are smaller and lighter.
10.	The work is held on the machine table by means of fixtures and clamping devices.	The work is clamped directly on the table or held in a vice or chuck.

SLOTTING MACHINE

Its construction is similar to that of a vertical shaper. Its ram moves vertically and tool cuts driving down ward stroke only. Its main use is in cutting different types of slots in most economical way. Its other uses are machining irregular shapes, circular surfaces and other pre marked profiles both internal as well as external.

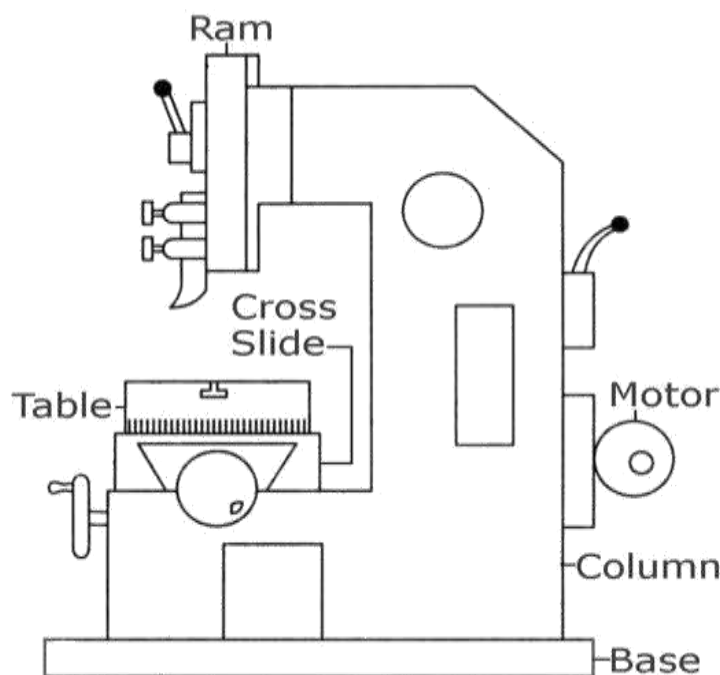

MAIN PARTS:

- 1. Base:** It is a heavy cast Iron construction and acts as a support for the column, the driving mechanism ram, table and all other fittings. At its top it carries horizontally ways along which the table can be traversed.
- 2. Column:** It is another heavy cast Iron body, which acts as a housing for the complete driving mechanism. At its front it carries vertical ways, along which the ram moves up and down.

3. Table: Usually circular table is provided on the top of the table are provided T-slots to clamp the work or facilitate the use of fixtures.

4. Ram: It moves in vertical direction, between the vertical guide ways provided in front of the column. At its bottom, it carries the tool post in which the tool is held. The cutting action takes place during the down ward movement of the ram.

SIZE AND SPECIFICATIONS:

The size of the slotting machine is generally given in terms of maximum length of stroke. The size of the job that can be machined will be less than this size by an amount equal to the sum of the top and bottom clearances of tool.

TYPES OF DRIVES:

Mainly three types of driving mechanisms are used in slotting machines for driving that ram.

1. Slotted disc mechanism.
2. Slotted link and gear mechanism, and
3. Hydraulic mechanism

1. The slotted disc mechanism: It is the simplest of all the methods commonly used for driving the ram of a slotting machine. The driving mechanism consists of, a pinion, a gear a slotted disc and crank. The disc carries a T-slot through which passes a crank pin. Its distance from the centre of the disc can be adjusted as desired.

The main driving pulley, situated at the rear side of the machine is driven by a motor through belts it in turn drives the pinion which drives the gear. The gear being on the same shaft as the disc and drives the disc. The crank and connecting rod mechanism converts the circular motion of the disc in to reciprocating motion of ram. The length of stroke of ram can be varied by shifting the crank pin towards or away from the centre of the disc. The starting and finishing positions of the ram stroke can be adjusted by means of hand lever for stroke adjustment. The fly wheel provided at the rear side, acts as a shock absorber at the end of the stroke.

2. Slotted link and Gear Mechanism: This mechanism is used in heavier type slotting machines. The mechanism consists of two driving wheels provided with a trunnion. These trunnions work inside the bushed bearings provided on the sides of the machine. Both the wheels carry an eccentric each. Three bolts are provided by means of which the eccentrics can be made loose or fast with the driving wheels. A slotted link of bell crank type is provided between the driving wheels. The crank pin forms the fulcrum. A die of usually of bronze works in the slot of the link. It is provided with a hardened steel bush, through which passes one of the three bolts. This bolt connects the two eccentrics and carries the above die, so that when eccentric revolve, along the driving wheels the die slides in the slot. Other end of the link is attached to the ram by means of connecting rod. The ram carries a shackle at its top to carry the end of the counter weight arm. The other end of the arm carries the counter weight and the same is provided about a point in its length somewhere on the top of the frame of the machine.

The mechanism works such that as the eccentric revolve the die slides inside the slot of the link and in doing so, it makes the link swing about the fulcrum, provided by the crank pin. With the result, the connecting rod, and hence the ram is alternatively pushed up and pushed down. This enables the reciprocating motion of the ram and the tool. The length of stroke is adjusted by varying the swing of the link. For this the both are made loose and the eccentrics rotated to adjust the throw, i.e. the position of die with respect to centre of rotation of the wheels. After the required adjustment is obtained the both are again tightened to make the mechanism ready again.

4. **Hydraulic Mechanism:** The hydraulic drive used in slotters is the same as shapers. The axis of the cylinder in this case will be in a vertical direction. Both constant pressure and constant volume type drives are prevalent.

TYPES OF SLOTTING MACHINES

Slotting machines are mainly three types.

1. Puncher Slotters
2. Production Slotters.
3. Tool room Slotters.

1. PUNCHER SLOTTERS: These are heavy duty machines. Usually such jobs are machined which are heavier and have been roughly machined to required shape through other operations like sawing, forging or stamping etc. The slotting machine to the required shape and size.

2. PRODUCTION SLOTTERS: This is a common category of slotters generally used for production work. It consists of a heavy cast base and heavy frame, made usually in two parts. The upper part may be stationary type or tilting type. In tilting type of frames a worm and worm wheel are provided at the rear side to enable the tilting of the frame. The tilting type frame enables machining of tapered surfaces, in addition to the normal machining operations performed with a stationary type of frame.

The drive of the ram is obtained by means of a slotted disc and connecting rod. The fly wheel is fitted to prevent shock at the end of the stroke. The ram carries V-slides with hardness ground faces. Two loose strips, fitted vertically in front of the frame, form guide ways for the ram. One of these is secured rigidly to the frame and the other carries adjusting screws to take up wear. The lower part of the frame is provided with horizontal ways. On this is fitted the cross slide, which can be given transverse motion by means of hand wheel. The table is mounted on the cross slide and can be given cross motion by means of a hand wheel. The table carries teeth along its periphery and can be rotated by means of worm meshing with these teeth.

3. TOOL ROOM SLOTTERS: These slotting machines are of precision type and are used for very accurate machining. Usually tilting type frame is provided in these machines to enable machining at different angles. Slotted link type drive is commonly used. Rest of the construction is similar to that of production Slotter.

OPERATIONS:

Its main use is in cutting different types of slots and is most economical for this kind of work. Its other uses are machining irregular shapes, circular surfaces and other pre marked profiles both internal as well as external. Its construction is similar to that of a vertical shaper. Its ram moves vertically and tool cuts during down ward stroke only.

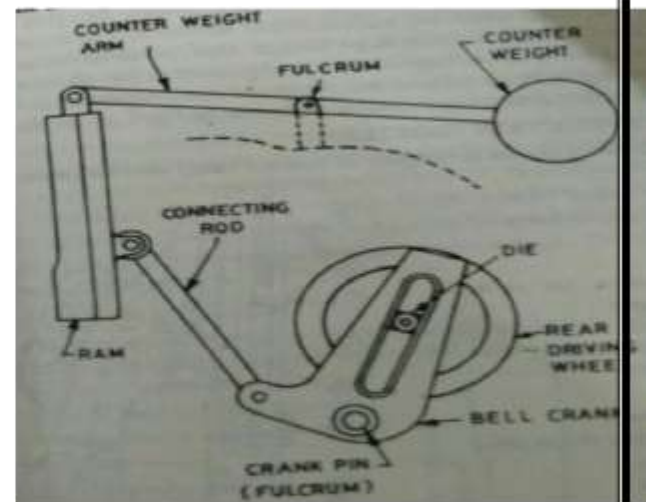
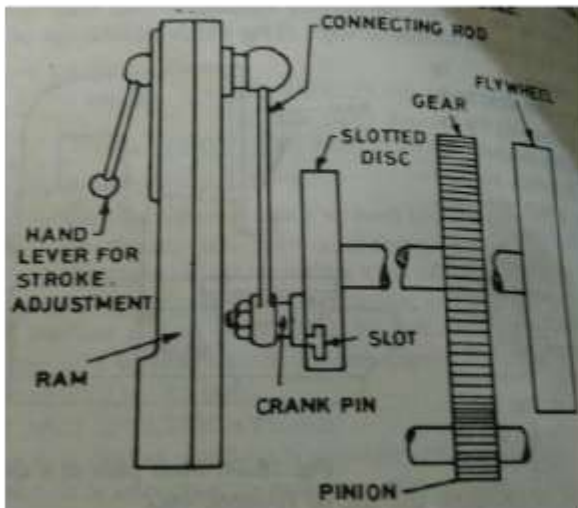

DRILLING

Drilling is an operation to produce holes in a solid metal by means of a revolving tool called drill. The drilling is followed by reaming for dimensional accuracy and fine surface finish by means of a multi-tooth revolving tool called reamer.

Boring is the operation for enlarging an existing hole previously produced through drill, cast, punched or by any other suitable operation.

The operations of drilling, boring and reaming can be performed both by hand feed as well as power feed on a large number of machines such as centre lathe, drilling machine, boring machine, turning mill (vertical lathe) Capstan and Turret Lathes, Automatic Lathes etc.

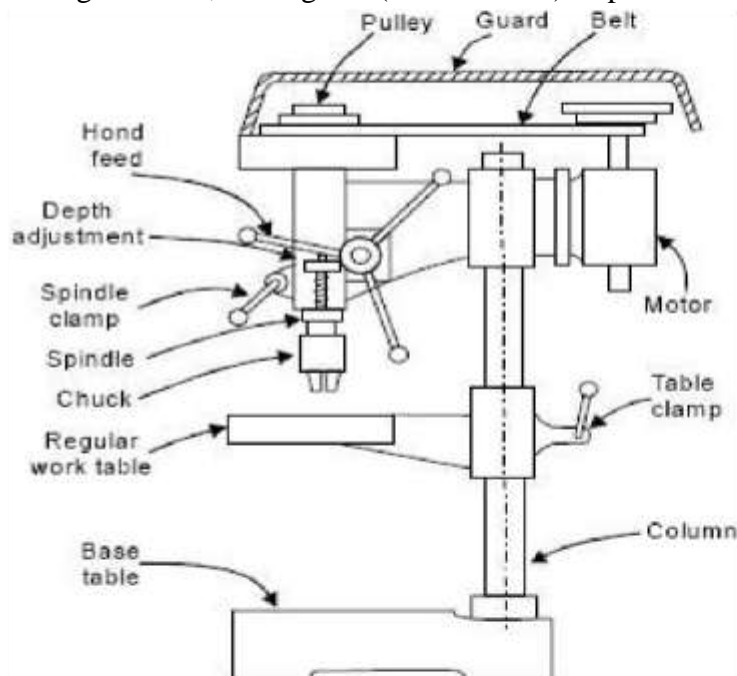

DRILL SIZE AND SPECIFICATIONS:

According to the Indian standards the drills are specified by their diameters, series they belong to, the material they are made of and the IS number. These data are mainly based on the material for which the drill is to be normally used. They are made in 3 types:

1. Type-N → For normal low Carbon Steel.

2. Type-H → For hard materials.
3. Type -S → For soft and tough materials.

Example: A twist drill specified as “9.50 IS: 5101 HS” means a twist drill of 9.50mm dia.

Confirming to IS: 5101 made of high speed steel unless otherwise mentioned in the tool designation the type should be taken as ‘N’ and the point angle as 118° .

In metric sizes the drills are normally manufactured in diameters ranging from 0.2mm to 10mm.

TYPES OF DRILLING MACHINES:

Drilling machines are manufactured in various sizes and varieties to suit the different types of work. They are broadly classified as:

- | | |
|---|---|
| 1. Portable drilling Machine. | 2. Sensitive or Bench drill. |
| 3. Upright drilling Machine (Single Spindle Type) | 4. Upright drilling Machine (Turret Type) |
| 5. Radial drilling Machine | 6. Multiple spindles drilling Machine. |
| 7. Deep hole drilling Machine | 8. Gang drilling Machine. |
| 9. Horizontal drilling Machine | 10. Automatic drilling Machine. |

1. PORTABLE DRILLING MACHINE:

It is a very small, compact and self-contained unit carrying a small electric motor inside it. It is very commonly used for drilling holes in such components that can't be transported to the shop due to their size or weight. On account of the high speeds available considerable time is saved. Another advantage is that the holes can be drilled at any desired inclination. Portable drills have a capacity to drill holes up to max. of 18mm dia.

2. SENSITIVE OR BENCH DRILL:

This type of drill machine is used for very light work. Its construction is very simple and so is the operation. No gears are used in the drive. It can be swung to any desired position. Vertical movement to the spindle is given by the feed handle through a rack and pinion arrangement. The max. dia. it can drill is 20mm dia steel.

3. UPRIGHT DRILLING MACHINE (SINGLE SPINDLE):

It is used for heavier work and has a back gearing arrangement. It differs from sensitive drill in its weight, rigidity, application of power feed and wide range of spindle speeds. The drilling capacity is up to 75mm in steel. The table can swung to any position with rotary movement. It enables any part of the surface to come under the tool without disturbing work.

4. UPRIGHT DRILLING MACHINE (TURRET TYPE):

It is a production drilling machine and is very useful when a series of different size holes are to be drilled repeatedly or number of different operations like drilling, reaming, counter boring, counter sinking, spot facing etc are to be performed in sequence repeatedly. The turret head which carries six, eight or ten different tool mounting positions is mounted on a ram. It can be easily indexed to bring the proper tool in operating position over the work and can be raised or lowered by moving the ram upwards or downwards. The required tools are mounted in sequence in the turret head so that they automatically come in operating position when the head is indexed. This type of machine eliminates tool changing time and a single machine can be used to perform no. of different operations one after the other.

5. RADIAL DRILLING MACHINE:

This machine is very useful because of its wider range of action. Its principal use is in drilling holes on such work which is difficult to be handled frequently. In this the tool is moved to the desired position instead of moving the work for drilling.

Based on the type and number of movements possible, the radial drill can be broadly grouped as:

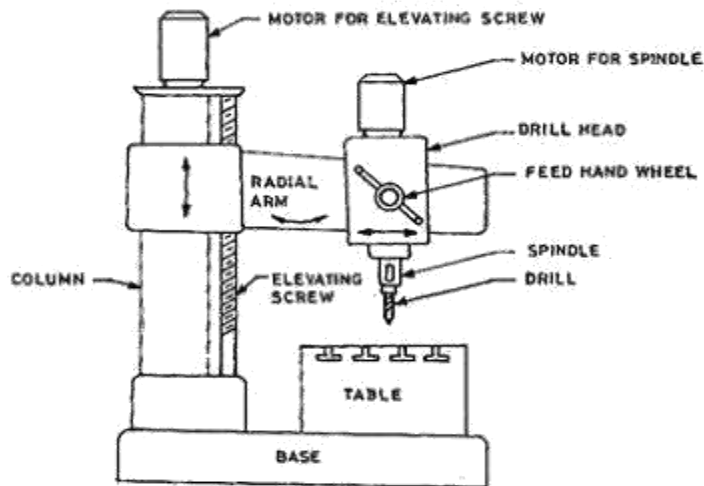

i. Plain Radial drill: Three principal movements are possible in this type of machine. Viz. vertical movement of the arm along the column, horizontal sliding movement of the drilling head or spindle head along the arm and radial swinging of the arm in horizontal plane.

ii. Semi-Universal Radial drills: These machines in addition to the above three basic movements, carry provision for swinging of spindle head about horizontal axis which is normal to the arm. Thus the head, hence the spindle can be inclined to a suitable angle with its normal vertical position on either side, enabling drilling of holes at desired inclination with the normal vertical position.

iii. Universal Radial drills: in this machine, the arm itself can be rotated through a desired angle along horizontal axis. This is in addition to the four possible movements available on a semi-universal machine. Thus this machine is highly versatile and facilitates drilling at any desired inclination and location. It is normally provided with a geared drive.

6. MULTIPLE SPINDLES DRILLING MACHINE:

These machines are mostly used in production work and are so designed that several holes of different sizes can be drilled simultaneously increasing the production with sufficient accuracy. In these two or more spindles are driven from a common driving shaft through worm and worm gears or belts. Drill heads with a capacity to drive up to 50 spindles simultaneously are available. In these heads it is possible to adjust the spindles to several different positions to enable drilling of holes at any location within the area covered by the head.

7. DEEP HOLE DRILLING MACHINE:

Where very long holes of relatively smaller diameter are required to be drilled these machines are used, such as in rifle barrels and long spindles. These machines can be horizontal as well as vertical types, according to the requirements. These machines are provided with head stock and a carriage. The work is mounted between these two and the carriage carries the drill. On the head stock side, the work is supported on a spindle which also rotates the same as the drill is fed slowly.

In deep hole drilling operation, the work rotates at high speed, while the drill is fed in to the work at low speed and feed. Since the drill is quite long it is required to be supported, so is the case with the work piece, for which steady rests are used. Coolant is simultaneously fed to the cutting edges through the passages and it will cool the cutting edges and takes away the chips along with it. The drill is withdrawn each time it has cut through a length equal to its diameter. This helps in easy removal of the chips from the hole. Horizontal designs are used for longer jobs and vertical designs are used for relatively shorter jobs.

8. GANG DRILLING MACHINE:

It is a multiple spindle drilling machine and all the spindles are arranged in a row. These spindles are driven either separately or collectively. This machine is very useful when the nature of work is such that a number of operations like drilling, reaming, counter boring and tapping etc are to be performed in succession on it. The work moves from one spindle to the other, after each operation. The number of spindles depends upon the type of production. Four spindles are very common. One operator can perform all the operations.

9. HORIZONTAL DRILLING MACHINE:

All drilling machines, except one variety of deep hole drilling machines, are of vertical type. In these machines the spindle and the tool are in horizontal position and are mainly used for long jobs, such as columns pipes and barrels etc which are difficult to be drilled in vertical position. The horizontal drilling is also used for jobs of excessive weight and extraordinary large size jobs which can't be handled easily. The operation of drilling performed by keeping the job stationery and moving the machine.

10. AUTOMATIC DRILLING MACHINE:

These are production machines arranged in series to perform a number of different operations in sequence at successive work stations. The work pieces, after completion of an operation at one station, are automatically transferred to the next station for another operation. The operation sequence, related cutting speeds, feeds, start and finish of the operation at each station etc are so arranged and synchronized that once the work piece is loaded at the first station, it automatically switches on to the next operation and unloaded.

Several different operations like drilling, boring, tapping, milling, honing etc can be performed on a job in succession on these machines.

OPERATIONS DONE ON DRILLING MACHINES:

1. Drilling
2. Reaming
3. Boring
4. Counter boring
5. Counter sinking
6. Spot facing
7. Tapping

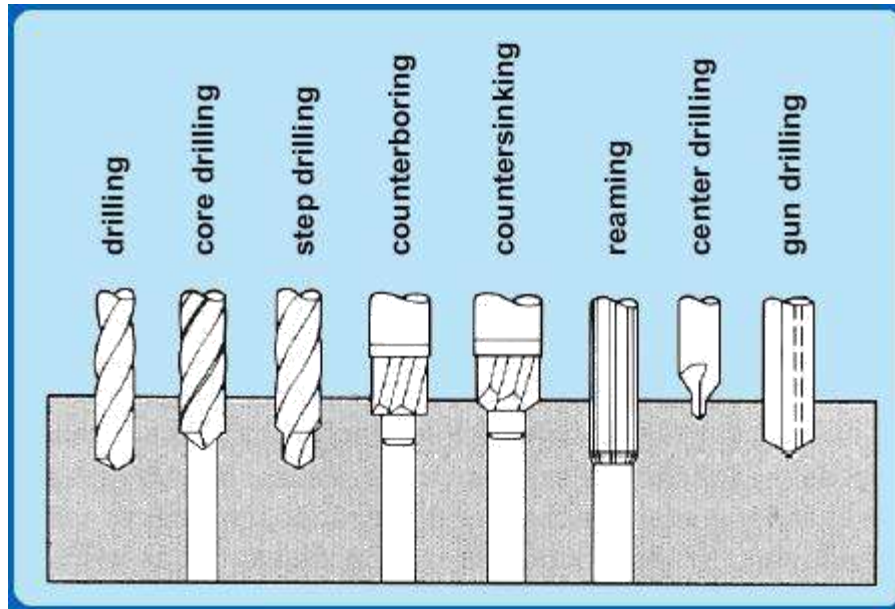

- 1. Drilling:** It is the main operation done on drilling machine. It is the operation of producing a circular hole in a solid metal by means of a revolving tool called drill bit.
- 2. Reaming:** It is the operation of finishing a hole to bring it to accurate size and have a fine surface finish. The operation is performed by means of a multi-tooth tool called reamer. The operation serves to produce a straight, smooth and accurate hole. The accuracy to be expected is within $\pm 0.005\text{mm}$.
- 3. Boring:** It is an operation used for enlarging a hole to bring it to the required size and have a better finish. It involves the use of an adjustable cutting tool having a single cutting edge. It can be used for correcting the hole location and out of roundness, if any, as the tool can be adjusted to remove more metal from one side of the hole than the other. It is a slower process than reaming. The accuracy to be expected is within $\pm 0.0125\text{mm}$.
- 4. Counter Boring:** The operation is used for enlarging only a limited portion of the hole, is called counter-boring. It can be performed by means of a double tool boring bar or a counter boring tool. In order to maintain alignment and true concentricity of the counter bored hole with the previously drilled hole, the counter boring tool is provided with a pilot at its bottom.
- 5. Counter Sinking:** It is the operation used for enlarging the end of a hole to give it a conical shape for a short distance. This is done for providing a seat for the counter sunk heads of screws, so that the top face of screw matches with the main surface of work. The standard counter sunk carry included angle of 60° , 82° or 90° .
- 6. Spot facing:** This operation is used for squaring and finishing the surface around and at the end of a hole, so that the same can provide a smooth and true seat to the underside of bolt heads or collars etc. This is usually done on castings or forgings. The hole may be spot faced below the rough or above it, i.e. on the upper surface of the boss if the same is provided.
- 7. Tapping:** It is the operation done for forming internal threads by means of a tapping tool. To perform this operation the machine should be equipped with a reversible motor or some other reversing mechanism. Drill size for tapping = $0.08 \times$ tapping size. Drill size = tap size - $2 \times$ depth of thread.

TOOL HOLDING DEVICES:

Taper shank drills, of which the shank is sufficiently large, are directly fitted in the tapered hole of the spindle nose. The taper shank tools of which the shank is too small to fit the taper hole of the spindle are held in a socket. The shank of this socket has a standard taper

to fit in to the taper hole of the spindle. Still the smaller taper shank drills or other tools are first fitted with a sleeve, which fits in to the socket and the complete assembly in the spindle. The socket as well as sleeve both carries a key slot each and a tang is provided at the end of the tapered hole and helps in providing a positive drive for the tool as the grip of taper alone is not sufficient. The drift helps in taking out the socket, sleeve or the tool by driving it in to the key slot. By doing so the drift presses against the top of the tang and because of the taper on the shank as well as the corresponding hole, the part or the tool is driven out. Straight shank drills are always held in a drill chuck.

Holding Parallel Shank Drills:

A drill chuck is the most useful device for holding the parallel shank drills and other small tools. Two types of chucks are commonly used.

1. Self centering three-jaw Chuck.
2. Quick change Chuck.

A drill chuck is capable of holding wide range of drill sizes and it is usually provided with radial fingers for this purpose. The chuck key is used for rotating the tool head body of the chuck. Inside the body, there are three radial fingers which carry teeth on their outer faces. These teeth mesh with three toothed blocks, mounted on ball bearings inside. For operating the chuck, the pilot of the key is inserted in the pilot hole so that the teeth of the gear, provided on the key, engage with the teeth provided on the body. As the key is rotated, the outer body rotates together with the toothed blocks inside. This forces the fingers to move out wards or in wards, depending on the direction of rotation of the key. This enables a firm gripping of the tool or its loosening respectively. While operating this chuck, the drill spindle has to be stopped and then only the key is fitted and rotated.

Quick change Chuck: It is mainly used in mass production work. The main advantage of this chuck is that the machine spindle is not required to be stopped, while changing the tool. Thus a number of tools can be held and replaced quickly, one after the other, without stopping the spindle. This type of requirement is always there, when a number of different operations like reaming, boring, spot facing etc are to be performed repeatedly on the same machine, such that a different tool is to be held for each operation.

A drill chuck is normally permanently fitted to the drill spindle on smaller and lighter type of drill machines. But on larger and heavier type of machines, the chucks carry standard taper shanks, which fit in to the corresponding tapered holes in the spindles.

TWIST DRILLS:

Twist drill is the most widely used tool in modern drilling practice. It consists of a cylindrical body carrying two spiral flutes cut on it. Twist drills are usually made of high speed steel. They are made in various sizes to suit the work and are provided with either tapered shank or parallel shank. Small drills say up to 12.7mm dia. are provided with parallel shank and larger sizes with tapered shank. Morse taper is commonly used for the tapered shank. Other types of shanks used on twist drills are bit shank and ratchet shank, but they are not very common.

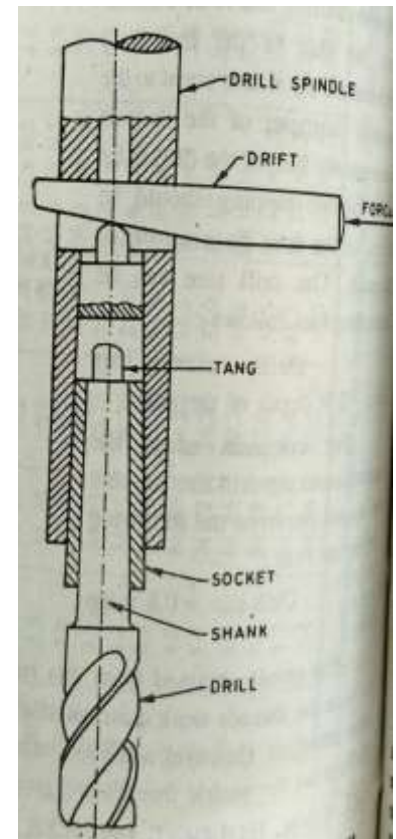

Twist drill consists of two main parts. Viz. a **shank**, which is gripped in the drill chuck or sleeve and the other the **body**, which forms the main cutting unit.

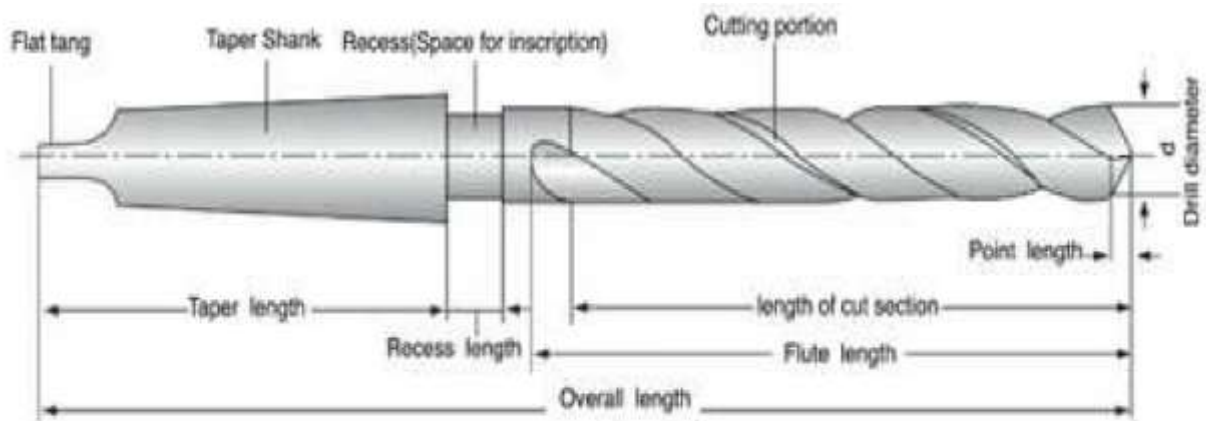

Tapered shank drills carry a tang at the end of the shank to ensure positive grip. The body consists of flutes, for removal of chips, the lips or cutting edges, the point or dead centre. The land or portion of full diameter which guides the drill in the hole and the body clearance or relief.

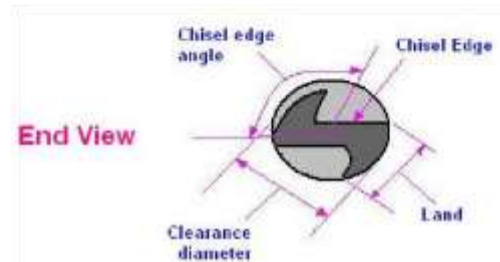

The drill should be so ground that the point is exactly in the centre i.e. the axis of the body and the lips are of equal angle and length. This will enable the production of a perfectly round, smooth, parallel and accurate hole of desired size and the drill will have better life. Unequal lips result in an over sized hole. This can be easily tested by drilling a small hole in mild steel. If the drill is correctly ground the spirals of chips that cut out will be exactly alike. If one is smaller than the other, or is broken it indicates an incorrect grinding. Alternatively, a drill grinding gauge can be used to test the same.

The advantages of using twist drills are:

1. The chips and cuttings of the metal are automatically driven out of the hole through the flutes.
2. Cutting edges are retained in good condition for a long time, thus avoiding the frequent re-grinding of the drill.
3. Heavier feeds and speeds can be used safely, resulting in a considerable saving of time.
4. For the same size and depth of the hole, they need less power in comparison to other forms of drills.

TWIST DRILL PARTS:

The twist drills are made to carry one of the following two types of spiral grooves on the body.

1. HIGH HELIX: They carry a helix angle of 35° to 40° and a heavy web. Their groove width is larger than that of the usual twist drills and therefore they enable easier and quicker disposal of chips. They are largely used for deep hole drilling especially in low tensile strength materials like Copper, Aluminum die casting alloys, Plastics, Wood etc. They are also known as **Fast spiral drills**.

2. LOW HELIX: They carry a small helix angle and are relatively more rigid. On account of their high rigidity, they are capable of taking higher torque and heavier feeds. They are widely used in general drilling work. They are also known as **Slow spiral drills**.

The detailed description of the different parts of a twist drill and their functions are as follows:

- 1. Body:** It is that part of the drill which carries flutes and extends from dead centre up to the start of the neck.
- 2. Axis:** The longitudinal centre line of the drill, along which the whole body, neck and shank of the drill are concentric, is called the axis of the drill.
- 3. Chisel edges or dead centre:** The short edge formed at the extreme tip end of the drill, due to the inter section of the flanks, is called the chisel edge or dead centre. It coincides with axis of the drill. Some of the drills carry a screw type or spiral shaped chisel edge instead of a sharp edge type. This facilitates more accurate location of holes and lower axial thrust.
- 4. Shank:** The portion of the drill beyond neck, which is gripped in the holding device (ex- Drill chuck, sleeve etc), is called Shank.
- 5. Point:** The cone shaped surface at the end of the flutes, formed by grinding, and containing the dead centre, lips and flanks etc is known as point.
- 6. Lip or Cutting edge:** It is the main cutting part of the drill and is formed by the inter section of each flank and face. There will be so many lips in a drill as the number of flutes and the faces. In a commonly used twist drill there are two lips, because it carries two flutes and two corresponding flanks. For correct drilling it is essential that both lips should be of equal length and be equally inclined with axis of the drill.
- 7. Body Clearance:** A small reduction in the diameter of the body is provided on the drill adjacent to the land is called body clearance. It helps in reducing friction between the drill and the walls of the hole and thus helps in both metal cutting and increasing tool life.
- 8. Land or Margin:** It is a narrow flat surface which runs all along the flutes of the drill on its leading edges. The diameter of the drill measured across its lands determines its correct size. The functions of the lands are to keep the drill aligned during the operation and produce the correct size hole.
- 9. Lip clearance:** That part of the conical surface of point, which is ground to provide relief near the cutting edge, is called lip clearance.
- 10. Face:** The curved surface of the flute near the lip is called face. The chips cut from the material, slide up wards along this surface.
- 11. Flutes:** The helical grooves in the body of the drill are known as flutes. Commonly used drills carry two flutes, while special drills carry four. These flutes make the chips curl and provide passage for their exit. Cutting edges are formed on the point due to machining of these flutes and the cutting fluid reaches the cutting area through these flutes only.
- 12. Flank:** It is the curved surface, on either side of the dead centre, which is confined between the cutting edge on its one side and the face of the other flutes on the other side.
- 13. Web:** The central metal column of the drill body that separates the flutes from one another is known as web. Its thickness gradually increases from the tip side towards the shank side, where it is maximum. This will provide strength and rigidity to the drill.
- 14. Chisel edge corner:** The point of inter section of the chisel edge and the lip is known as chisel edge corner.
- 15. Outer Corner:** The extreme of the dead centre, where the face and flank intersect to form a corner is called outer corner.
- 16. Neck:** The smaller diameter cylindrical portion, which separates the body and shank of a drill, is called neck. All necessary particulars of the drill are engraved on this portion.
- 17. Tang:** The flat portion of rectangular cross-section provided at the end of the tapered shank is known as tang. This fits in to a matching slot in the holding device, such as socket,

sleeve or spindle to provide a positive drive. Also for driving the drill out of the sleeve or spindle, the drift is applied over this part of the drill.

18. Heel: An edge is formed where the body clearance and the flute of the drill intersect. This edge is known as Heel.

DRILL DIMENSIONS:

The important dimensions of drill are:

- 1. Diameter:** The linear measurement perpendicular to the axis and across the lands of a drill, at the outer corners.
- 2. Length of body:** It is the length measured along the axis between the dead centre and start of neck of the drill.
- 3. Flute length:** The length measured parallel to the axis between the dead centre and the point of termination of the flute near the neck.
- 4. Lip length:** The distance between the chisel edge corner and the outer corner is called lip length.
- 5. Overall length:** The distance measured along the axis between the dead centre and the extreme end of the tang is known as overall length. In the case of parallel shank drills, which carry no tang, it is the distance between dead centre and extreme end of shank measured along the axis of drill.
- 6. Depth of body clearance:** The body diameter is slightly reduced either side and is measured along the radius of the drill, perpendicular to axis.
- 7. Core taper:** It is the measure of the increase in web thickness or core thickness, starting from the minimum at the point end and to the maximum at the shank end of the drill.
- 8. Lead of helix:** It is the axial distance measured between two corresponding points on a flute in its one complete turn.

IMPORTANT ANGLES OF A DRILL

Different angles are provided on a drill for efficient metal cutting. The main angles are:

- 1. Rake angle:** It is also known as helix angle. It is the angle formed between a plane containing drill axis and the leading edge of the land. It can be positive, negative and zero value. For right hand flutes it is positive, for left hand flute it is negative and for parallel flutes it is zero. For most drills the rake angle varies from 0 to 48° . However 16° to 32° is common for normal materials. Higher values are suitable for soft material and lower value for hard materials. Larger the value of this angle, lesser will be the torque required and vice-versa.
- 2. Point angle:** It is also known as cutting angle. The most commonly used value for large variety of materials is 118° . However it varies from 80° to 140° smaller cutting angle for brittle materials and larger for harder and tougher materials. It is the angle included between the two opposite lips of a drill measured in a plane containing the axis of the drill and both the lips.
- 3. Lip Clearance angle:** The angle formed between the flank and a plane normal to the axis, measured at the periphery of the drill. Its value varies from 8° to 15° for most of the drills but 12° are most common. It enables easy entry of the drill.
- 4. Chisel edge angle:** When the drill is viewed from its end, there appears to be an obtuse angle formed between the lip and chisel edge. This is called chisel edge angle. It determines the clearance on the cutting lip near the chisel edge. The greater this angle larger will be the clearance. Normally this angle varies between 120° to 135° .

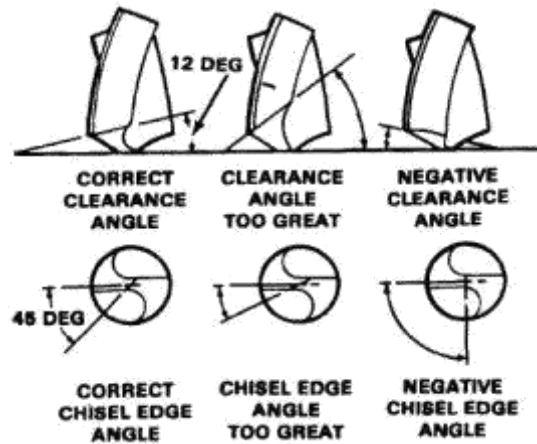

STRAIGHT FLUTE DRILLS:

Twist drill is not suitable for drilling holes in softer materials like brass as it will pull through the back of the metal. A straight fluted drill is proper tool for such work. The only disadvantage is chips clog in the flutes then in spiral flutes. Mainly used for drilling holes in sheet metal.

BORING MACHINES:

The operation of a boring is enlargement of an already existing hole. This hole can be due to previous drilling, or produced in casting or forging. Small holes, particularly in small jobs the boring operation can easily done on centre lathe or capstan and turrets of medium size. For large and heavy jobs special boring machines are used, which make the operation easy and efficient. These machines are production machines for boring on a large scale.

Classification of Boring Machines:

Boring machines are manufactured in various different designs & sizes. They can be broadly classified in to the following three types.

1. Horizontal Boring Machines.
2. Vertical Boring Machine.
3. Jig Boring Machine.

The first two types are production machines used in general production work, the last one is a precision machine, used for precision boring operations, such as Jig Boring. Horizontal Boring Machine:

Horizontal boring machines are of various types such as **Table type, Planer type, Floor type, and Multiple head type** etc each of these suitable for a certain range of operations, but of all these the table type or universal type is most versatile and commonly used. The spindle of this machine is capable of holding drills, and milling cutters as well to perform the operations of drilling and milling hence this machine is called horizontal boring, drilling and milling machine.

The principal parts of this type of machine are:

1. Two vertical columns, one on each end of the table.
2. A head stock which can be moved vertically, along the main column.
3. A horizontal spindle, suitably housed in the head stock, which can be rotated and fed forward and backward according to requirement.
4. A load bearing end support, for supporting the end of a long boring bar, which can be adjusted vertically along the end support column.
5. A horizontal table, mounted on a saddle that can be moved horizontally forward and backward and sideways by moving the saddle.

6. A heavy and strong bed, which carries the entire load of different parts, work piece and tooling over it.

Floor type Horizontal Boring Machine:

This machine is comparatively heavier type of horizontal boring machine. The operating and spindle supporting units are not mounted on a bed, as in the table type machine, but are carried on separate run ways, which facilitates the movement of these units, together with the spindle past the work. The work does not move at all, but is kept stationary at a platform floor plate. It is this relative movement of work with respect to the other units of the machine in which it differs from the table type machine. This type of the machine is very suitable for long and heavy jobs.

Planer type Horizontal Boring Machine:

This machine resembles in construction with the table type. The only difference in the construction and operation of the work supporting mechanism. In this a heavy cross-bed is incorporated between the spindle column and the end support column. This bed is mounted across the axis of the spindle and carries a table over it. On its two sides it carries two columns. The main column carrying the head stock, is rigidly fixed, whereas the end-support column can move towards or away from this bed along the horizontal ways provided on the top of the cross bed, at right angles to the former bed. The job is mounted on the table. In operation, it resembles a planer in that the tool is held between the two columns or mounted on the head stock only and the work, mounted on the table, moves past the tool. This type of machine is very suitable for long jobs.

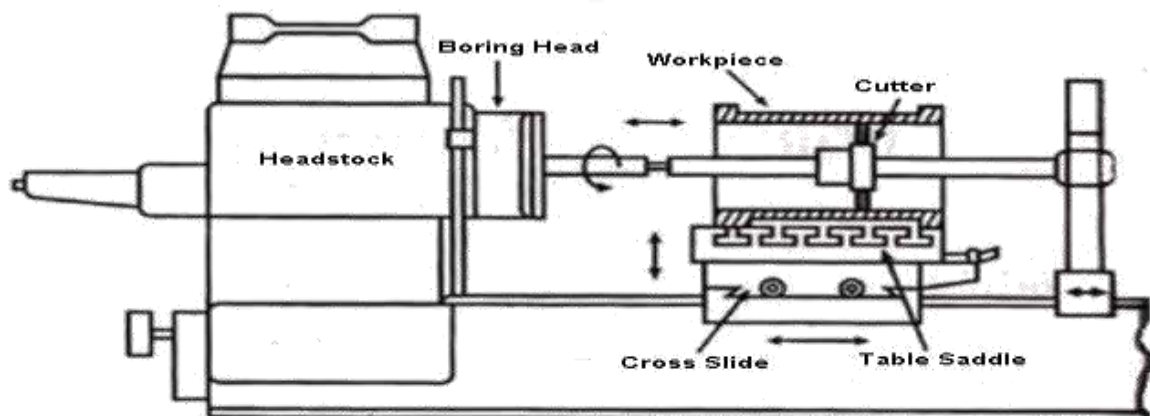
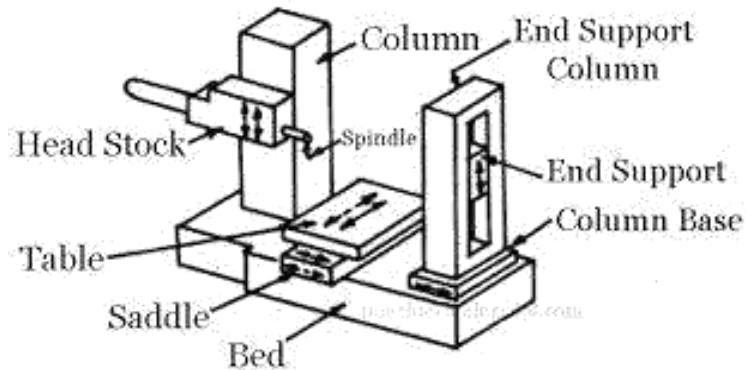

Table Type Horizontal Boring Machine

Multiple Head type Horizontal Boring Machine:

It consists of two vertical columns mounted on the sides of a stationary bed. The columns are bridged by means of a cross-rail. As a maximum four head stock can be mounted on the machine, one each on the two vertical columns and two on the cross-rail. The head stock on the columns will have horizontal spindles and those on the cross-rail vertical spindles. In this way maximum four tools can be mounted simultaneously on this machine. The work is mounted on the table, which is supported and moved on the bed. This machine resembles a planer type milling machine. The head stocks can be swiveled to desired angles if angular cuts are required to be taken. Machining on more than one surface on a job is possible simultaneously as up to four tools can operate simultaneously on the job from different angles and at different locations.



Vertical Precision Boring Machine:

It is a production machine basically designed for boring holes in cylinder blocks and liners of automobile engines, fine boring of parts in Ferrous and non ferrous metals etc.

Constructional Features:

Column and Base: The vertical column is a cast Iron box type casting with stiffening ribs inside. The base is another massive cast Iron structure and carries guide ways at its top face, along which table traverse column and base are fastened together rigidly. Prismatic guide ways are provided on the front face of the column along which the spindle head moves up and down. Lead screw of the spindle head is located between the two vertical ways at the front face of the column.

Spindle Head: It traverses in vertical direction along the column ways. The spindle head housing carries inside it the v- belt drive for spindle and hand traverse mechanisms. According to the size of the hole to be bored, one of the three inter changeable spindles, provided with the machine is mounted on the spindle head. A screw is provided with the machine is mounted on the spindle head. A screw is provided on the tool holder face for adjustment of overhang of the boring tool. A special dial is provided to show precision adjustment of the tool up to 0.02mm.

Speed and feed gear box: It is mounted inside the column on the machine base. It transmits the motion from the electric motor to the shaft of the spindle drive and to the lead screw of the indle head. The gear box provides 6 spindle speeds and 4 feeds and also rapid traverse to the spindle.

Table: It is made in two parts. The lower part moves in cross direction along ways provided on the base and the upper one in longitudinal direction along the ways provided on the top of the lower part. During the operation the table can be locked by means of stops to prevent its movement in either direction.

Salient Features:

1. The machine is highly rigid and vibration proof, maintains its initial accuracy of performance over a long period of time.
2. The control of speed and feed gear box is conveniently grouped in an easy to reach place and is performed by means of three levers.
3. Most of the machine units are assembled in independent housings which facilitates easy repair.
4. The table being movable in two directions permits to bore several holes in a work piece at one setting.
5. The upper limit of the spindle speed, ample power of motor and rigidity of the machine permit the use of carbide cutting tools.
6. Precision antifriction spindle bearing ensure machine durability, accuracy and surface finish.

Vertical Boring Machines:

In this the work is held on a rotary table, rotates about a vertical axis, while the tool remains stationary, except for feeding. The table together with the work rotates in a horizontal plane. Thus if the table is considered to have replaced the chuck or face plate of a centre lathe, this machine can be considered as a vertical lathe with its bed working as a head stock mainly the following three types of boring machines in this category.

1. Standard Vertical boring mills.
2. Vertical Turret Lathes.
3. Vertical Precision Boring Machines.

Standard Vertical Boring Mills: It consists of a heavy Cast iron bed, which carries a circular table over it. On the sides of the bed are two vertical columns which are bridged together by means of a cross-rail. As a maximum four tool heads can be mounted on the machine one each on the two columns and two on the cross-rail. This number can also be reduced according to the requirements. Usually the tool heads carry the provision for being swiveled to a certain angle for taking angular cuts. The work is mounted on the table which rotates about its vertical axis. The rotating work is thus, fed against fixed tools, which results in circular cuts being taken on the job. The table is provided with T-slots for clamping the work.

Usually large symmetrical work pieces, such as cylindrical objects are bored on these machines. A few examples are the casings for steam turbines, tables for machine tools and pressure vessels. Vertical housing on the two sides of the table limits the size of the work. The maximum size of the work would be equal to dia. of the table and same will represent the size of the machine.

Vertical Turret Lathe: It has a special advantage that many tools can be simultaneously mounted on the turret head, and therefore, a large number of different operations can be performed in addition to boring a single setting of work. The table of the machine is of rotary type and carries adjustable jaws for clamping the work.

The rotary table rotates over the bed, about a vertical axis. The work piece is held over this table. Maximum two side tool posts can be mounted, one each on each column. These tool posts can be adjusted vertically and they can also move forward and backward. One or two vertical tool heads can be mounted on the cross-rail, which can be adjusted horizontally along the cross-rail. Each vertical tool head will carry a turret head enabling to mount a number of tools in sequence on it to enable different operations to be performed in a single setting of tools. The turret head can be indexed after each operation, to bring the proper tool in position for the next operation. The vertical tool head can also be moved, upwards and down wards, according to requirement.

UNIT-4

MILLING MACHINE

Milling is a machining process of metal removal due to cutting action of a revolving cutter, when the work is fed past it. The revolving cutter is held on a spindle or arbor and the work clamped on the machine table, fed past the revolving cutter. In doing so, the teeth of the cutter remove the metal, in the form of chips, from the surface of the work to produce the desired shape.

It has a capability to perform large number of operations, which no other single machine tool can perform. It gives high production rate, with in very close limits of dimensions. that is why it has largely replaced other machine tools like shaper, planer, slotter etc for small and medium size jobs only. It is too slow for machining very long jobs. For small and medium jobs, the milling machine gives the fastest production with a very high accuracy. It has very wide application in mass production work.

Working Principle:

The metal removing operation on a milling machine, the work is rigidly clamped on the table of the machine and the revolving multi teeth cutter mounted on a spindle or an arbor. The cutter revolves at a high speed and the work fed slowly past the cutter. The work can be fed in a vertical, longitudinal or cross direction. As the work advantages, the cutter teeth remove the metal from the work surface to produce the desired shape.

Size and Specification:

Size of the milling machine is usually denoted by the dimensions (length and breadth) of the table of the machine. Different manufactures, denote these sizes by different numbers 0,1,2,3,4,5,6 etc. each of these numbers indicates a particular standard size. Other main specifications are the Horse power of driving motor, number of spindle speeds, feeds, drive, taper of spindle nose, required floor area etc.

Types of Milling Machines:

A large variety of different types of milling machines are available, the broad classification of these machines is as follows:

1. Column and knee type milling machines.
2. Fixed bed type or manufacturing type milling machines.
3. Planer type milling machines.
4. Production milling machines.
5. Special purpose machines.

1. Column and knee type Milling Machines

These machines are all general purpose machines and have a single spindle only. They derive their name “column and knee” type from the fact that the work table is supported on a knee like casting, which can slide in vertical direction a long a vertical column. These machines depending up on the spindle position and table movements are further classified as follows:

- a) Hand Milling Machine.
- b) Plain or Horizontal Milling Machine.
- c) Vertical Milling Machine.

MACHINE TOOLS

- d) Universal Milling Machine.
- e) Omniversal Milling Machine.

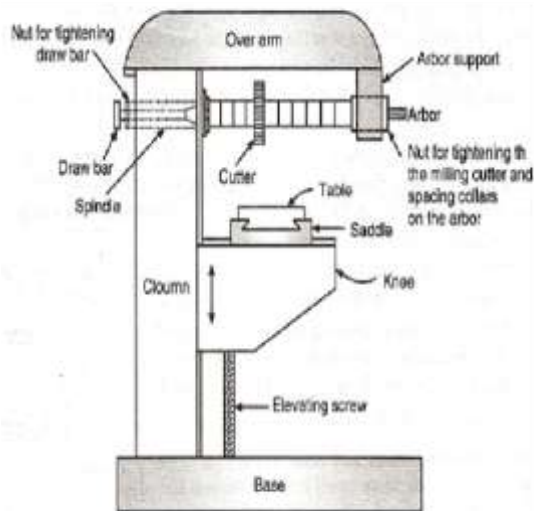

III B.Tech I Sem (Mech)-R17

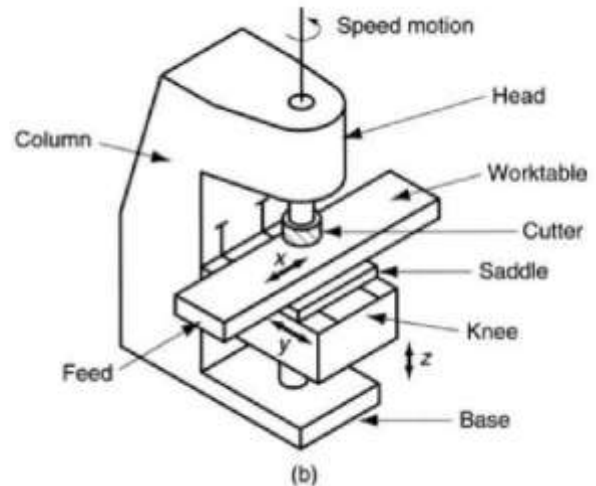

Fig. (b) vertical knee-and-column milling machine

2. Fixed bed type or manufacturing type Milling Machines:

These machines, in comparison to the column and knee type, are more sturdy and rigid, heavier in weight and larger in size. They are not suitable for tool room work. Most of these machines are either automatic or semi-automatic in operation. They may carry single or multiple spindles. The common operations performed on these machines are slot cutting, grooving, gang milling and facing. They facilitate machining of many jobs together, called multi-piece milling. Their further classification is as follows:

- a) Plain type (having single horizontal spindle)
- b) Duplex head (having double horizontal spindles)
- c) Triplex head (having two horizontal and one vertical spindle)
- d) Rise and fall type (for profile milling)

3. Planer type Milling Machines:

They are used for heavy work. Up to a maximum of four tool heads can be mounted over it, which can be adjusted vertically and transverse directions. It has robust and massive construction like a planer.

These are also manufacturing machines, but differ from the above machines in that they do not have fixed bed. They include the following machines.

- a) Rotary table or Continuous type.
- b) Drum type.
- c) Tracer controlled.

5. Special purpose machines:

- a) Thread Milling Machine
- b) Profile Milling Machine
- c) Gear Milling or Gear hobbling Machine
- d) Cam Milling Machine
- e) Planetary type Milling Machine
- f) Double end Milling Machine
- g) Skin Milling Machine and
- h) Spar Milling Machine.

a) Hand Milling Machine:

It is the simplest of all the milling machines and smallest in size. All the operations, except the rotation of arbor, are performed by hand. The table carrying the work over it is moved by hand to feed the work. This machine is especially useful in producing small components like hexagonal or square heads on bolts, cutting slots on screw heads, cutting key ways etc.

b) Plain or Horizontal Milling Machine:

The vertical column serves as a housing for electricals, the main drive, spindle bearing etc. The knee acts as a support for the saddle, work table and other accessories like indexing head etc. Over arm provides support for the yoke which in turn supports the free end of the arbor. The arbor carrying the cutter rotates about a horizontal axis. The table can be given straight motions in three directions, longitudinal, cross and vertical (up and down) but can't be swivelled. For giving vertical movement to the table the knee itself, together with the whole unit above it, slide up and down along the ways

provided in front of the column. For giving cross movement to the table the saddle is moved towards or away from the column along with the whole unit above it. A brace is employed to provide additional support and rigidity to the arbor, when a long arbor is used. Both hand and power feeds can be used for the work.

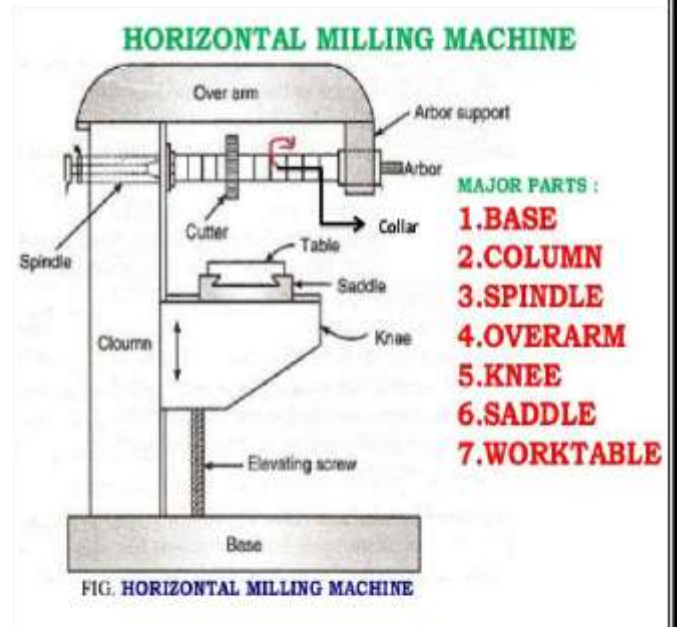

c) Vertical Milling Machine:

It derives its name from the vertical position of the spindle. This machine is available in both types, the fixed bed type as well as column and knee type.

It carries a vertical column on a heavy base. The over arm in this machine is made integral with the column and carries a housing at its front. This housing called head can be fixed type or swiveling type. In fixed type, the spindle always remains vertical and can be adjusted up and down. In swiveling type, the head can be swiveled to any desired angle to machine the inclined surfaces.

The knee carries an enclosed screw jack, by means of which it is moved up and down along the parallel vertical guide ways provided on the front side of the column.

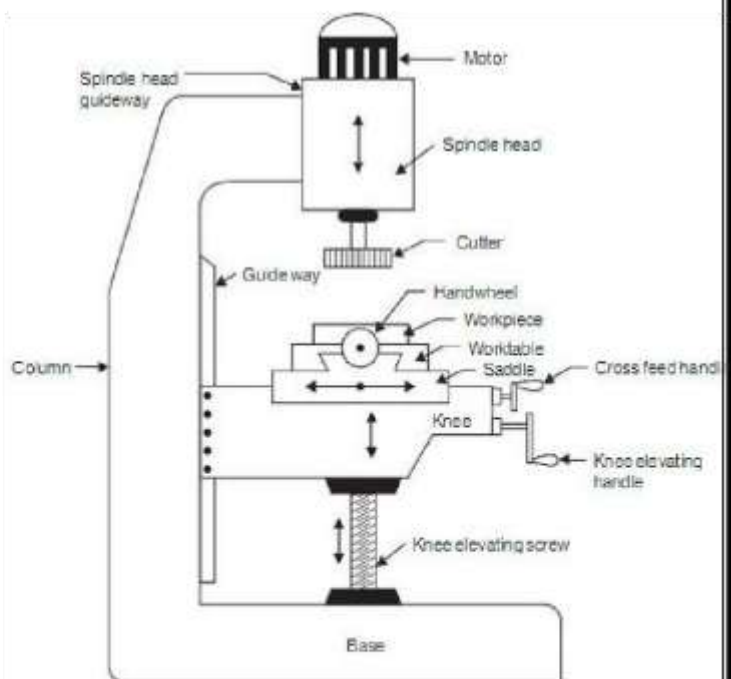

Fig. 4.10 Vertical milling machine

The saddle is mounted on the knee and can be moved, along the horizontal guide ways provided on the knee, towards or away from the column. This enables the table to move in cross-direction. The table is mounted on guide ways, provided on the saddle, which are in a direction normal to the direction of the guide ways on the knee. By means of the lead-screw, provided under the table, the table can be moved in the longitudinal direction. Thus the work gets up and down movement by the knee, cross movement by saddle and longitudinal movement by the table. Power feeds can be used to both the saddle and the table. Mostly face milling cutters and shell-end type cutters are used on these machines.

d) Universal Milling Machine:

It is the most versatile of all the milling machines and after lathe it is the most useful machine tool as it is capable of performing most of the machining operations. With its application the use of a large number of other machine tools can be avoided. It differs from the plain milling machine only in that, the tool can be given one more additional movement. Its table can be swivelled on the saddle in a horizontal plane. For this circular guide ways are provided on the saddle along which it can be swivelled. A graduated circular base is incorporated under the table, with a datum-mark on the saddle, to read directly the angle through which the table has been swiveled. This special feature enables the work to be set at an angle with the cutter for milling helical and spiral flutes and grooves. Its over arm can be pushed back or moved and a vertical milling head can be fitted in place of the arbor to use it as a vertical milling machine.

e) Omniversal Milling Machine: This is a modified form of plain milling machine and is provided with two spindles, of which one is horizontal, as in plain milling and the other is carried by a universal swiveling head and can be fixed in vertical position or can be set any desired angle up to 90° on both sides of vertical i.e. in a plane parallel to the front face of the column, and up to 45° in a plane perpendicular to the former direction i.e. towards or away from the column. Another special feature of this machine is that it carries, in addition to all the possible adjustments provided in a universal milling machine, two more adjustments. These adjustments are of the knee which can be swiveled about a horizontal axis to tilt the table and can be moved horizontally also. These special features make it a very useful machine tool for tool room work as it facilitates various operations to be carried out in different planes and at different angles in a single setting of the work.

PRINCIPAL PARTS OF COLUMN AND KNEE TYPE MILLING MACHINES

Main parts of all the column and knee type milling machines are similar, the movements of the moving parts differ in them. All these machines essentially consists the following main parts:

- 1. BASE:** It is heavy casting provided at the bottom of the machine. It is accurately machined on both the top and bottom surfaces. It actually acts as a load bearing member for all other parts of the machine. Column of the machine is secured to it carries the screw jack, which supports and moves the knee. It also serves as a reservoir for the coolant.
- 2. COLUMN:** It a very prominent part of a milling machine and is produced with enough care. Various parts and controls are fitted to this. On the front face of the column are made the vertical parallel ways in which the knee slides up and down. At its rear side, it carries the enclosed motor drive. A cover is provided on this side, which can be opened to enable accessibility to the drive. Top of the column carries dove-tail horizontal ways for the over arm.

3. KNEE: It is a rigid casting, which is capable of sliding up and down along the vertical ways on the front face of the column. This enables the adjustment of the table height. The adjustment is provided by operating the elevating jack provided below the knee, by means of a hand wheel or application of power feed. Machined horizontal ways are provided on the top surface of the knee for the cross traverse of the saddle and hence the table. For efficient operation of the machine, rigidity of the knee and accuracy of its ways play an important role. On the front face of the knee two bolts are usually provided for securing the braces to it to ensure greater rigidity under heavy loads.

4. SADDLE: it is the intermediate part between the knee and the table and acts as a support for the table. It can be adjusted cross wise, along the ways provided on the top of the knee, to provide cross feed to the table. At its top, it carries horizontal ways along which table moves during longitudinal traverse.

5. TABLE: It acts as a support for the work. The work is mounted on it either directly or held in the dividing head. It is made of Cast Iron, with its top surface accurately machined and carries longitudinal T-slots to accommodate the clamping bolts for fixing the work. Longitudinal feed is provided to it by means of a hand wheel fitted on one side of the feed screw. Cross feed is provided by moving the saddle and vertical feed by raising or lowering the knee. Both hand feed and power feed can be employed the adjustable stops should be used to trip out the same at the correct movement.

Modern milling machines provide rapid traverse in all the three directions to effect saving in time. In universal milling machines, the table can be swiveled in horizontal plane and the graduations on circular base help in adjusting required swivel.

6. OVER ARM: It is the heavy support provided on the top of both plain and universal milling machines it can slide horizontally, along the ways provided on the top of the column, and adjusted to a desired position in order to provide support to the projecting arbor, by accommodating its free end in yoke. If further support is needed, to have additional rigidity, braces can be employed to connect these when many cutters are used simultaneously.

Milling Methods

Milling is a process of metal cutting by means of a multi-teeth rotating tool, called cutter. The form of each tooth of the cutter is the same as that of single point tool. Each tooth after taking a cut comes in operation again after some interval of time. This allows the tooth to cool down before the next cutting operation is done by it. This minimizes the effect of the heat developed in cutting on the cutting edge. With cylindrical cutters, the following two methods are commonly used for cutting operation.

1. Up or Conventional Milling: In this method of milling, the cutter rotates in a direction opposite to that in which work is fed.

2. Down or Climb Milling: In this method the direction of rotation of the cutter coincides with the direction of work feed.

The relative directions of movements of the cutter and work should be noted at the point of contact between the two. In the conventional milling the chip thickness increases as the cut proceeds and in case of climb milling the chip thickness decreases as the cut proceeds. I.e. the chip thickness is zero at start of the cut and maximum at the end of the cut in conventional milling where as it is a reverse case in climb milling.

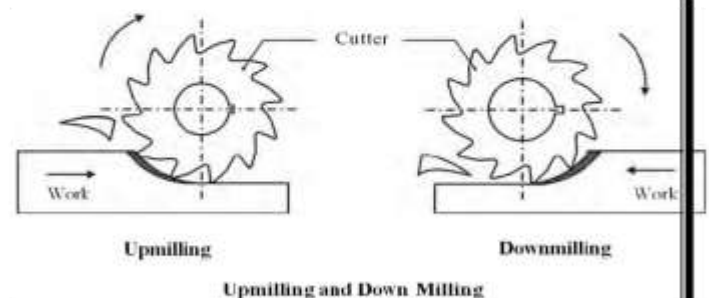

The section of a particular method of the above two, depends upon the nature of work. The conventional milling is commonly used for machining castings and forgings since this method enables the cutter to dig in and start the cut below the hard upper surface. The climb milling is particularly useful for finishing operations and small work, such as slot cutting, milling grooves, slitting etc. It gives a better surface finish if there is no backlash in feeding mechanism of the table and the work is rigidly held.

MILLING CUTTERS

The milling cutters may have either straight tooth i.e. parallel to the axis of rotation or in helical shape. The helix angle may be right hand or left hand and this will decide the direction of rotation of the cutter for performing the cutting operation. A milling cutter may be made of single piece of steel or having the cutting portion welded to a tough shank or having removable cutting teeth (bits) inserted in a solid body. The broad classification of milling cutter is according to the shape of the teeth they carry, such as plain, inserted, formed or saw teeth etc.

Common types of milling cutters are the following:

- | | |
|---|---------------------------|
| 1. Plain Milling Cutters | 2. Side Milling Cutters |
| 3. End Milling Cutters | 4. Face Milling Cutters |
| 5. Metal slitting Cutters (Slitting Saws) | 6. Angle Milling Cutters |
| 7. Formed Milling Cutters | 8. T-slot Milling Cutters |
| 9. Wood ruff-key Milling Cutters | 10. Fly Cutter |

1. PLAIN MILLING CUTTERS: These milling cutters may have the cutting teeth on their periphery and they may be either straight or helical. Their end faces are either ground square with the axis or slightly concave to reduce friction. Thus, no cutting action is provided by the side faces. These cutters are employed for milling flat surfaces parallel to the axis of rotation.

The milling cutters are made to have either fine pitch or coarse pitch. Fine pitch teeth cutters are used for light work and finishing work. The coarse pitch teeth cutters are called heavy duty slab milling cutters. They carry less number of teeth, having a steep helix angle. They are commonly used where very heavy cuts are to be used, since they are capable of removing more material with less power consumption.

2. SIDE MILLING CUTTERS: these cutters, apart from having teeth on the periphery, also have cutting teeth on one side or both sides. They are always provided with central hole for the purpose of mounting them on the arbor. They are also called staddle mills when used in pairs. The main types of side milling cutters are the following.

a) Plain side Milling Cutters: They are made to have cutting teeth on the periphery as well as on both sides. They are normally used for cutting slots or in face milling. These cutters are in different widths from 5mm to 25mm and dia up to 200mm.

b) Half side Milling: These cutters have teeth on the periphery and on one side only. They can be used for face milling. The teeth may be either straight or helical. Also they can be either left hand or right hand. Actual cutting action is performed by the teeth provided on the periphery while side teeth do the finishing and sizing work.

c) Staggered teeth side Milling Cutters: The cutters carry alternate teeth on the periphery only. These alternate teeth are of opposite helix angle, staggered from side to side, just as the teeth of wood saw, and cut alternately on one side and then on the other. They are commonly used for key-way cutting and slot cutting.

d) Interlocking side Milling Cutters: These cutters are similar in design to the side milling cutters but are used as a unit, consisting of two cutters joined together such that their teeth interlock. They can be adjusted to acquire the required width by inserting shims or spacers between them to make good the reduction in width of the cutters due to wear and frequent sharpening of the teeth. These cutters are used for milling wider slots to exact width.

3. END MILLING CUTTERS: These are solid circular cutters which are manufactured in two different varieties; those having shank and others which do not have shank. They carry teeth on the periphery as well as on the end. These teeth may be straight or helical. Helical teeth may be right hand and left hand. End milling cutters are used for milling slots, key ways, grooves and irregular shaped surfaces. Shank type end mills may have either taper shank or straight shank and diameters from 3mm to 50 mm.

4. FACE MILLING CUTTERS: These cutters are made in two common forms. The smaller type is known as shell-type-face milling cutter. It carries teeth on periphery as well as on end face. Maximum cutting is done by the teeth on the periphery and those on the end face perform finishing operation. The larger type of cutter, called the **built up face** milling cutter, consists of a steel body, along the periphery of which are inserted cutting teeth. The shell type face milling cutters are used for small work where as built up face milling for larger surfaces. The shell type cutter is usually held in a stub arbor and larger type can be mounted directly on the spindle.

5. METAL SLITTING CUTTERS: These cutters are also called metal slitting saws. They are used for cutting thin slots or parting off. They are very thin. They are in two varieties.

a) Plain Slitting Saws: They are plain milling cutters, which are very thin. Their teeth are provided with some side relief in order to prevent rubbing. They are made in different widths 1mm to 5mm.

b) Staggered teeth Milling Cutter (Saw): These saws are used for comparatively heavier work. They have their teeth staggered alternately and have side teeth also. These saws are in different widths, ranging between 4mm and 10mm.

6. ANGLE MILLING CUTTERS: These cutters carry sharp angular teeth which are neither parallel nor normal to their axes. Their specific use is in milling V-grooves, notches, dovetail slots, reamer teeth and other angular surfaces. The following two types of angular cutters are in common use:

a) Single Angle Cutter: these cutters may have their teeth either only on the angular face or on both, the angular face and side, which enables milling of both flank of the included angular groove simultaneously. Their teeth may have an included angle of 45° or 60° .

b) Double angle cutters: These cutters differ from the single angle cutters in that they have two angular faces which join together to form V-shaped teeth. The included angle of this 'V' is either 45° , 60° , or 90° , though it is not necessary that the angle of both the faces should be equal.

7. FORM MILLING CUTTERS: These are also known as form relieved milling cutters or radius cutters. This category includes large variety of milling cutters used for producing different shaped contours. Their teeth are provided with a certain angle of relief, so that their form and size are retained even after resharpener. The common types of form relieved cutters are:

- a) Corner rounding cutters: For milling edges and corners of the jobs
- b) Concave and convex cutters: Concave cutter for milling convex surface and convex cutter for milling concave surface
- c) Gear cutters: For milling gear teeth
- d) Tap and reamer fluting cutters: For milling flutes on reamers and taps
- e) Gear hobs: For cutting teeth of worm wheels, helical and spur gears
- f) Thread milling cutters: For milling different types of threads.

8. WOOD RUFF-KEY MILLING CUTTER: It is a small type of end milling cutter, up to 50mm dia. are to have solid shank, to be fitted in the machine spindle, where as larger sizes are provided with a hole for mounting the same on an arbor. Smaller sizes have straight teeth on the periphery with the sides having little clearance. Larger sizes are usually made to have staggered teeth both on the periphery as well as the sides.

9. T-SLOT MILLING CUTTER: It is a single operation cutter, which is used only for cutting T-slots. In similar sizes it is made to have the shank integral with the cutter. Large size cutters are mounted on a separate shank. In operation, the narrow groove at the top is first milled by means of a slotting cutter or end mill cutter. The T-slot milling cutter is then used for milling the wider groove.

10. FLY CUTTER: It is a single point tool, mounted on a cylindrical body, held in a stub arbor or held in a bar. Screws are used for tightly holding the tool in the holders. Cutting edge of the tool can be ground to any desired shape and is capable of producing a very accurate surface.

MATERIALS FOR MILLING CUTTERS

Materials used for manufacturing the milling cutters are the same as for lathe tools.

The common materials used are:

1. High Carbon Steel
2. High Speed Steel
3. Stellite
4. Cemented Carbides
5. Ceramics

High carbon steel is used for small scale production.

High speed steel is extensively used for solid type cutters.

Stellite is used for milling cutters for machining hard metals, forgings, castings etc.

Cemented Carbides are used in the form of bits for milling cutters when high speeds are used.

Ceramics are used for milling bronze and cast Iron. Twice the speed of Carbides.

ANGLES OF A PLAIN MILLING CUTTER:

A milling cutter can be considered as a built up unit of a number of single point cutting tools, such that each tooth of the cutter is a single point cutting tool. The relief angle α is the angle between the plain P_1 , which is normal to the axial plane PP at a point on the cutting edge, and the tangent to the relieved land of the outer tooth. This angle is measured in a plane perpendicular to the axis of the cutter. Higher the value of this angle, lessor will be the friction and hence less wear on the land.

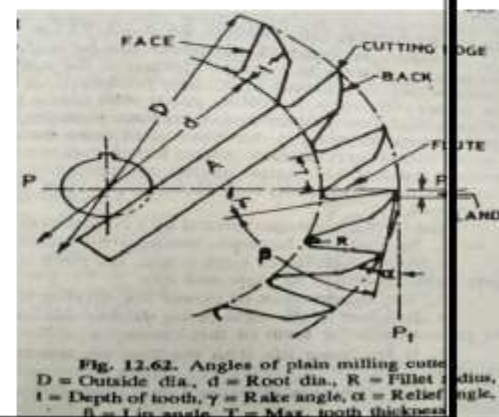

A larger relief angle will increase the tool life between two grinds and ensure better surface finish, but at the same time, due to consequent reduction in the lip angle (β), it will make the tooth weak. Normally relief angle ranges between 10° to 30° .

The rake angle (γ) is the angle between the axial plane PP and the face of the cutter tooth, measure in a plane normal to the cutting edge. Rake angle facilitates free cutting by the tool by allowing the chips to flow smoothly. This ensures the less consumption of power, better surface finish, less wear on the tool face and consequently a greater life of the tool between two grinds. However, it should not be increased beyond 20° otherwise, the resulting smaller lip angle will again weaken the tool.

The angle between the face and the land of the cutter tooth is called lip angle (β). Its value depends upon the values of rake and relief angles. Larger lip angle ensures stronger tooth and helps in milling harder metals and when deeper cuts are used.

INDEXING OR DIVIDING HEADS:

It helps in changing the angular position of the component in relation to the cutter. With their use, it is possible to divide the periphery of the work piece in to any number of equal parts. These heads are generally of the following three types.

1. Plain dividing head
2. Universal dividing head
3. Optical dividing head

Out of these, the optical dividing head is the most precision attachment and is therefore, used for very precision indexing work or for checking the indexing accuracy of the other types of dividing heads.

1. PLAIN DIVIDING HEADS: These dividing heads are mainly of two types. The first type carries the indexing plate directly mounted on its spindle and has no use of the worm and worm wheel. It is the simplest of all the dividing heads and is used in direct indexing. The index plate carries 12 or 24 equal spaced slots on its periphery. The job is held between two centers, one on the dividing head spindle and the other on the tail stock. The hand lever is used for locking the spindle in position. In operation, a lug engages the desired slot of the indexing plate. By means of this dividing head 2,3,4,6,8,12 and 24 divisions can be obtained when 24 slots plate is used and 2,3,4,6 and 12 divisions, when a 12 slot plate is used. The plate, tighter with the spindle, can be rotated by means of the handle provided on the left side of the dividing head.

Another useful form of the plain dividing head is the one used in simple indexing. It consists of a cast body, carrying the spindle. On the front end of the spindle are mounted the index

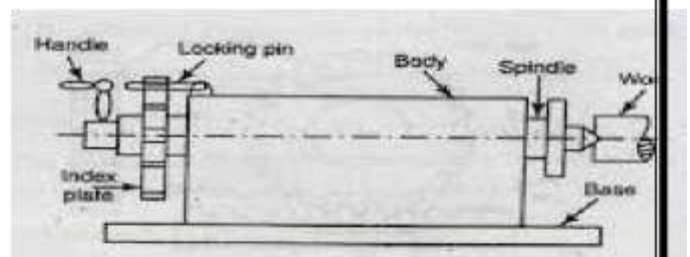

plate, having different hole circles on its face and teeth on its periphery. The plate gets movement through a worm by rotating the handle. The crank, carrying the pin, is mounted on a bolt about which it can be swung to any desired position to bring the pin in front of the desired hole. Usually, plates having 3 circles of 16, 42 and 60 or 24, 30 and 36 holes are provided on these heads. The job is held between the centers.

2. UNIVERSAL DIVIDING HEAD:

This type of dividing head is a very useful device for the purpose of indexing work. It essentially consists of a fairly robust body, enclosed in it is the worm drive, which consists of a worm wheel. The dividing head spindle carries a worm wheel.

The spindle carrying the worm, meshes with the worm wheel, carries a crank at its outer end. The index pin works inside the spring loaded plunger. This plunger can slide radically along a slot provided in the crank in order to adjust the pin position along a desired hole circle on the index plate. The index plate is also mounted on the same spindle as the crank, but on a sleeve such that the worm spindle, and hence the crank can move independent on the index plate. The sector arms provided on the index plate are usually of detachable type and can be set at a desired angle with one another in order to set a definite distance along a desired hole circle. The index plates are available in a set of two or three, with a number of hole circles usually on both sides on them. The spindle carrying the worm wheel is provided with a job carrier (driving device) and a centre at its front end. On the back side of the dividing head is provided a bracket, which carries a slot along its length. One or two studs, according to requirement, can be fitted in this slot and predetermined set of change gears can be mounted on them.

The universal dividing head performs the following operations:

1. It sets the work piece in a desired position in relation to the machining table.
2. After each cut, it rotates the job through a desired angle, thus indexes the periphery of the work.
3. It provides a continuous rotary motion on the during milling of helical grooves.
4. It, in conjunction with a tail stock, acts both as a holding as well as a supporting device for the work during the operation.

USING DIVIDING HEAD

The dividing head provides support to the job, holds it in position and rotates it through a desired angle after each cut is over. The index crank is rotated to provide the rotary motion to the job and the index plate enables this rotation to take place always through a desired angle. When the crank is rotated, the worm rotates which, in turn, rotates the worm wheel. Since this wheel is mounted directly on the spindle, the latter rotates along with the former. The job, being secured to the spindle, by means of a suitable holding device, also rotates as the spindle rotates. The angle, through which the job will rotate, for each revolution of the crank, depends up on the velocity ratio, between the worm and worm wheel. This ratio is usually 40 to 1 i.e. for 40 revolutions of the worm, or of the crank, the job will make one revolution. If the worm is single start, the worm wheel will have 40 teeth along its periphery. However, some dividing heads carry a different velocity ratio of these two and the same should be known before performing the actual indexing operation.

A set of change gears can be incorporated to connect the worm shaft and the spindle. These gears are mounted on the left hand side of the dividing head. The index plates, normally 2 or 3 in number are provided with a number of circles on each face. Each of these circles carries a definite number of holes on them. The standard brown and sharp index plates having the following circles:

- No.1. 15, 16, 17, 18, 19, 20
- No.2. 21, 23, 27, 29, 31, 33
- No.3. 37, 39, 41, 43, 47, 49

Some German made dividing heads, which are commonly supplied with a set of 3 index plates carrying hole circles as follows: (Wider range)

_____	One Side 13, 16, 18, 20, 23
Plate No.1	
_____	Other Side 15, 17, 19, 21, 24
_____	One Side 27, 28, 31, 37, 41, 47
Plate No.2	
_____	Other Side 29, 33, 39, 43, 44, 49
Plate No.3	_____ One Side 18, 19, 20, 23, 29, 33, 39, 43, 49
	_____ Other Side 15, 17, 19, 21, 27, 31, 37, 41, 47

For using the dividing head, first it is to be calculated as to how many full turns, the crank has to rotate through and how many holes on which circle it has to cross further in order to give the required rotation to the work. After that, the sector arms are opened out to accommodate as many holes on that circle, between them, as the crank has to move through for the part of its revolution. Before rotating the crank, the crank pin is withdrawn by pulling the plunger. It rotates independent of the index plate. In differential indexing, where the plate has also to rotate, the same is unlocked.

INDEXING METHODS

Indexing is dividing the job periphery in to a desired number of equal divisions. It is accomplished by a controlled movement of the crank such that the job rotates through a definite angle after each cut is over. The following methods of indexing are commonly used.

1. Direct Indexing
2. Plain or Simple Indexing
3. Compound Indexing
4. Differential Indexing
5. Angular Indexing

Direct Indexing: It is the simplest case of indexing in which a plain dividing head is used. The index plate is directly mounted on the spindle and rotated by hand. It can be used only when the number of divisions to be obtained is such that the number of slots on the periphery of the index plate is a multiple of the number of divisions. The indexing ratio is obtained by:

$$\text{Required ratio} = \frac{N}{n}$$

N = No. of slots on the periphery of index plate
n = No. of divisions required to be obtained

For example, if the circumference of the job has to be divided in to 6 equal divisions and the

index plate has 24 slots, then the required ratio will be = $\frac{24}{6} = \frac{4}{1}$ i.e. the index plate will be required to move through 4 slots after each cut is over.

Alternatively, the plain indexing head can also be used for direct indexing. For this, the worm will have to be kept out of mesh with the worm wheel and the ratio obtained in the same way. For example suppose we have to divide the circumference of the job in to 10 equal divisions we select the 60 holes circles and calculate the movement of the crank pin as

follows. The required movement = $\frac{60}{10} = 6$ divisions on 60 holes circle.

2. Plain or Simple Indexing: This method of indexing is used when the direct method of indexing cannot be used for obtaining the required number of divisions on the work. For example: if the work required to be divided into 22 equal divisions the direct indexing cannot be used, because 22 is not divisible into any of the hole circles on the direct indexing plate. For such cases, simple indexing can easily be used.

For this, either a plain indexing head or a universal dividing head can be used. This method of indexing involves the use of the crank, worm, worm wheel and index plate. As already described, the worm wheel carries 40 teeth and the worm is single start. The worm wheel is indirectly mounted on the spindle.

When the crank pin is pulled outwards and the crank is rotated, the worm will rotate which, in turn will rotate the worm wheel, and hence the spindle and the work. Since the worm has single start thread and the worm wheel 40 teeth, with one turn of the crank (i.e. of the worm) the worm wheel will rotate through one pitch distance i.e. equal to $\frac{1}{40}$ of a revolution. Similarly 2 turns of crank will make the work to rotate through $\frac{2}{40}$ and 3 turns through $\frac{3}{40}$ of a revolution. Thus the crank will have to be rotated through 40 turns in order to

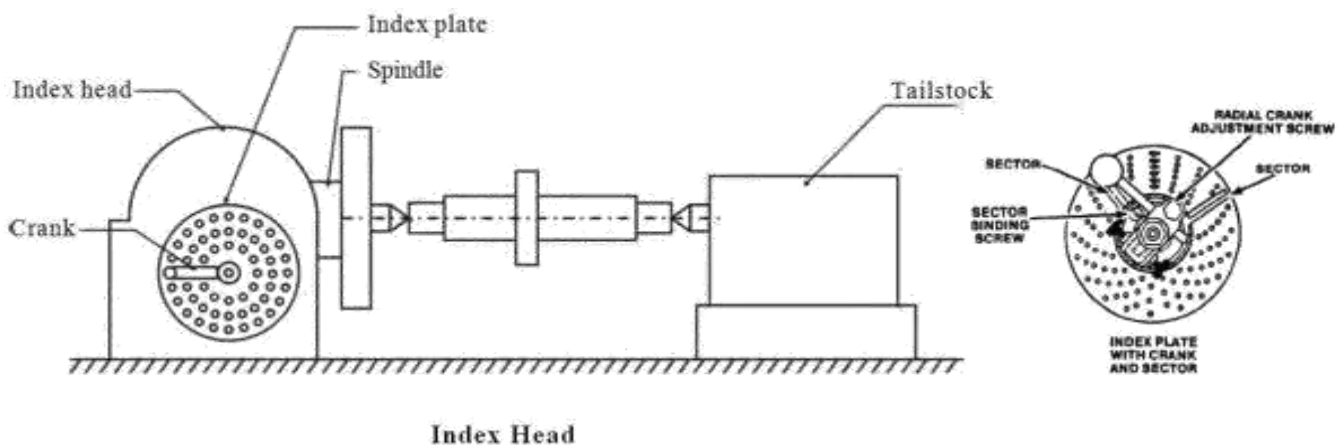

rotate the work through one complete turn. The holes in the index plate serve to sub-divide the rotation of the index crank.

For 2 divisions on the work, the crank will make $\frac{40}{2} = 20$ turns for each division.

For 4 divisions on the work, the crank will make $\frac{40}{4} = 10$ turns

For n divisions on the work, the crank will make $\frac{40}{n}$ turns

Let us consider that the work has to be divided into 23 equal divisions, then the corresponding crank movement will be given by

Crank movement = $\frac{40}{23} = 1 \frac{17}{23}$ turns.

Now, the whole number indicates, the number of full turns the crank has to move through, and fraction represents the part of the turn that the crank has to make in addition to the above, in order to make the work to rotate through one required division i.e. $\frac{17}{23}$ of a revolution.

In the fraction, the numerator denotes the number of holes to be moved and the denominator the number holes on the circle to be used. Thus for the above indexing, for each division on the job, the crank will make one complete revolution and will move further through 17 holes on the 23 holes circle.

To set the spacing on the index plate and avoid error and confusion in counting the holes every time, the sector arms should be used. These arms can be set, such that they will contain between them only as many holes on a particular circle as are required. This spacing can be maintained for as many operations as desired. For giving full turn to the crank, the pin can be withdrawn from the hole and the crank turned. For the remainder, the pin should be moved from one arm to the other and then engaged. After engaging the pin the arms can be moved further to set the spacing for the next operation.

Examples:

1. It is required to divide the periphery of a job in to 60 equal divisions. Find the crank movement?

$$\text{Required movement} = \frac{40}{60} = \frac{2}{3} \times \frac{6}{6} = \frac{12}{18} \text{ i.e. 12 holes on a 18 holes circle.}$$

2. Required 35 divisions on a plate. Find the indexing movement

$$\text{Required movement} = \frac{40}{35} = \frac{8}{7} = 1\frac{1}{7}$$

$$\text{Now } \frac{1}{7} = \frac{1}{7} \times \frac{3}{3} = \frac{3}{21} \text{ Select a 21 holes circle}$$

i.e. 1 full turn and 3 holes on a 21 holes circle.

In case of fractions, multiply the denominator by any such a number, that the result will give you one number or the other on any of the 3 plates. Multiply the numerator also by the same number.

3. Compound Indexing:

This method of indexing is used when the number of divisions required is outside the range that can be obtained by simple indexing. It involves the use of two separate simple indexing movements and is performed in two stages;

1. By turning the crank a definite amount in one direction in the same way as in simple indexing.
2. By turning the index plate and the crank both either in the same or reverse direction, thus adding further movement or subtracting from that obtained in the first stage.

Principle of Compound Indexing:

Let us consider that the crank is turned 3 holes on a 18 holes circle and the index plate and crank both turned 5 holes on 20 holes circle. On account of these two movements the worm will be turned through:

$$\frac{3}{18} + \frac{5}{20} = \frac{5}{12} \text{ Of a revolution.}$$

Since 40 turns of the worm turn the work through 1 revolution.

Therefore $\frac{5}{12}$ turn of the worm, will turn the work through $\frac{5}{12} \times \frac{1}{40}$ revolution

$$\text{i.e.} = \frac{1}{96} \text{ of a revolution.}$$

This will enable 96 divisions on the work.

Similarly let us consider another case, where in the second operation the index plate and crank are rotated in a reverse direction to that adopted in the first operation.

Suppose the crank is turned 5 holes on the 18 holes circle in one direction and then the index plate along with the crank turned 2 holes on 20 holes circle in a direction opposite to the first on account of these two movements the worm will be turned through:

$$\frac{5}{18} - \frac{2}{20} = \frac{64}{360} = \frac{8}{45} \text{ of a revolution}$$

Now the corresponding movement of the work will be $\frac{8}{45} \times \frac{1}{40} = \frac{1}{225}$ of a revolution.

Procedure: In order to obtain the required number of divisions, through compound indexing method proceed as follows:

1. Factorize the number of divisions required.
2. Factorize the standard no. 40
3. Select for trial any two circles on the same plate and on its same side factorize their difference.
4. Factorize the number of holes of one circle.
5. Factorize the number of holes of the other circle.

After obtaining these factors place them as follows:

$$\frac{\text{Factors of divisions required} \times \text{Factors of difference of hole circles}}{\text{Factors 40} \times \text{Factors first circle} \times \text{Factors of second circle}}$$

First Check:

If suitable index circle have selected, then all the factors in the numerator will be cancelled by those in the denominator. That is we will get unity in the numerator. If it does not happen, select another set of circles and make another attempt in the same way as above. Repeat it till unity is obtained in the numerator.

Now, suppose the above expression, after simplification, comes to the form $\frac{1}{x}$, where x may be any number. If a and b denote the numbers of holes on the two circles, then the required indexing movement is given by $\frac{X}{a} - \frac{X}{b}$ or $\frac{X}{b} - \frac{X}{a}$

The positive part of the two indicates the movement of the crank is one direction and the negative part denotes the movement of plate and crank in the opposite direction. It is always advisable to keep the backward motion as smaller of the two.

Second Check:

After finding the above two expressions, check that the algebraic sum of the two movements i.e. of the crank in one direction, and that of the crank and plate in the opposite

direction, should be equal to $\frac{40}{N}$, where N is the number of divisions required.

$$\frac{X}{a} + \frac{X}{b} = \frac{40}{N}$$

Example: Compound indexing for 87 divisions.

Suppose we select circles of 29 and 33 holes.

Putting the relevant factors in the form of the above stated expression and applying the first check we get:

$$\frac{3 \times 29 \times 2 \times 2}{2 \times 2 \times 2 \times 5 \times 29 \times 3 \times 11} = \frac{1}{110}$$

i.e. we get unity in the numerator, indicating the circles selected are correct.

Therefore, the required indexing movement is given by

$$\frac{110}{29} - \frac{110}{33} = 3\frac{23}{29} - 3\frac{11}{33} \quad \text{Or} \quad \frac{110}{33} - \frac{110}{29} = 3\frac{11}{33} - 3\frac{23}{29}$$

Since there are 3 common complete turns in each case they cancel out leaving the required

movement as: $\frac{23}{29} - \frac{11}{33}$ or $\frac{11}{33} - \frac{23}{29}$

Since we keep the forward motion of the crank as larger than the backward motion of the plate and crank path, we adopt the first expression for the required indexing movement.

$$\text{i.e. the movement} = \frac{23}{29} - \frac{11}{33}$$

The work will be indexed through $\frac{1}{87}$ of a revolution each time as the crank is moved forward 23 holes on 29 holes circle and the plate and crank backward 11 holes on 33 holes circle.

$$\frac{23}{29} - \frac{11}{33} = \frac{40}{87} = \frac{40}{N}$$

Now applying the Second Check $\frac{40}{87} = \frac{40}{N}$ confirm that the movements obtained are correct.

4 Differential indexing:

In principle it is not much different from compound indexing. It is also carried out in two stages. First the crank is moved in a certain direction. In the second operation that follows either some movement is added to the above crank movement or subtracted from the same. However, the said loss or gain in the movement is obtained by moving the plate by means of a train of gears, connecting the dividing head spindle to the worm spindle. The said motion is gained by rotating the index plate in the same direction as crank and it is lost by rotating the plate in the opposite direction to that of the crank. During differential indexing the index plate locking pin should be taken out to make the plate free to rotate.

The dividing heads are supplied with standard set of change gears. Change gears supplied with Brown & Sharp dividing heads are the following:

24 (2 No s) 28, 32, 40, 44, 48, 56, 64, 72, 86, 100

In addition to this, some dividing heads are provided with following set of gears

46, 47, 52, 58, 68, 76, 84

German made universal dividing heads are provided with following set of gears

24 (2 No s) 28, 32, 40, 44, 48(2), 56, 64, 72, 86, 96, 100

Both simple and compound gear train is used in differential indexing. In these gear trains, the first driver is always mounted on the main spindle of the dividing head, i.e. the same spindle on which is mounted the worm wheel inside and the job at the other end. The last driven is mounted on the worm spindle, which drives the index plate. The simple train consists of only one driver and one driven, connected together through one or two idle gears.

The compound train consists of two drivers and two driven wheels. The first driven and 2nd driver gears are mounted on a stud, incorporated between the dividing head

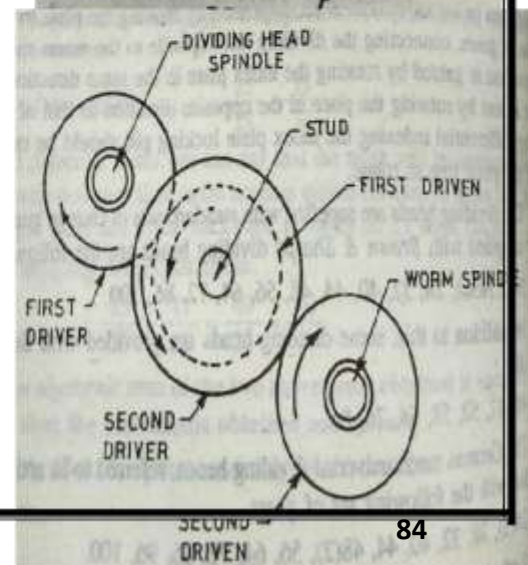
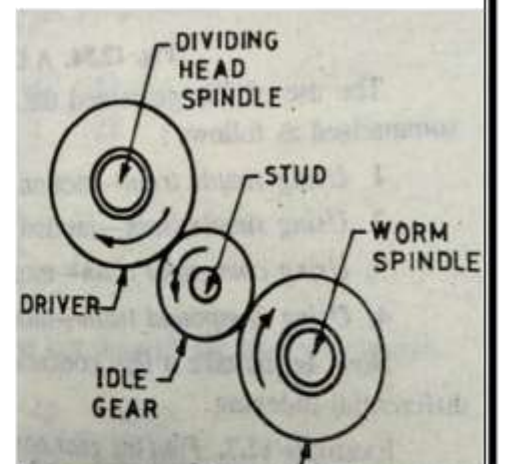

spindle and the worm spindle. Idle gear may or may not be used. If it is used, it should be incorporated between the 2nd driver and 2nd driven. The motion in indexing is so transferred that, when the crank is rotated the worm wheel, and hence the spindle, is rotated in the usual way. This, in turn rotates, the first driver. The motion is transferred to the last driven gear. This through the worm spindle is ultimately transferred to the index plate. the direction of rotation of index plate depends upon the type of gear train employed and the number of idle gears used there in. the index plate is required to be rotated in the same direction as the crank if motion is to be gained and in reverse direction if the same is to be lost.

The use of idle gears and the consequent loss or gain of motion can be summarized as follows:

1. Using simple train----- Motion is gained by using 1 idler.
2. Using simple train----- Motion is lost by using 2 or no idler.
3. Using compound train----- Motion is gained by using no idler.
4. Using compound train-----Motion is lost by using 1 idler.

Example: Find the gear combination and indexing movement necessary for 139 divisions. Let us select a number slightly greater or smaller then the given number, such that the selected number can be easily indexed through simple indexing.

Let us select the new number as 140

Simple indexing for 140 divisions = $\frac{40}{140} = \frac{2}{7} = \frac{6}{21}$
 i.e. 60holes on 21 holes circle.

Now, if the index crank is turned $\frac{6}{21}$ of a revolution 139 times, it will make

$$\frac{6}{21} \times 139 = 39 \frac{15}{21} \text{ Revolutions.}$$

Whereas, for complete one turn of the job it should make 40 complete revolutions. Obviously, the job would not be, thus indexed through exactly 139 equal divisions. The total movement done by the crank is short of the required 40 turns by

$$40 - 39 \frac{15}{21} = \frac{6}{21} \text{ of a revolution.}$$

This fraction is to be gained by the movement of the plate. In order to gain the movement, the plate will have to be turned in the same direction as crank. Also, in order than the divisions are equal, this movement is to be gained gradually, such that certain amount of it is added equally to the crank movement in all the 139 movements of the latter, so as to make it complete 40 turns at the end of these movements. This will be done by using suitable gear train.

Now, the gear ratio = $\frac{6}{21} = \frac{2 \times 3}{3 \times 7} = \frac{32 \times 24}{48 \times 56} = \frac{\text{drivers}}{\text{driven}}$

i.e. First driver 32 teeth, First follower 48 teeth.

Second driver 24 teeth, Second follower 56 teeth.

5. Angular Indexing:

We have seen that 40 turns of the crank make the work rotate through one complete turn. That is 40 turns of the crank make the work to rotate through 360° . Therefore for each one turn of the crank the work will rotate through $\frac{360}{40} = 9^{\circ}$

Now let us consider 18 holes circle.

If the crank is moved through 18 holes on 18 holes circles, i.e. one turn, it will make the work to turn through 9° . If it is moved 9 holes i.e. half turn on this circle, the work will rotate

through half the above angle i.e. $\frac{9}{2} = 4 \frac{1}{2}^{\circ}$

Again it is moved 2 holes on this circle i.e. $\frac{2}{18}$ or $\frac{1}{9}$ of a turn,

The work will rotate through $\frac{9}{9} = 1^0$

1 turn of the crank will rotate the work through

$9^0 \frac{1}{9}$ turn through 1^0

$\frac{2}{9}$ turn through 2^0

$\frac{3}{9}$ turn through 3^0 and so on

Angle required

Or we can say that crank movement = $\frac{\text{Angle required}}{9}$

Now the simple indexing method can be used for indexing when full, half, one third and two third degrees are involved

Example: 1. Index for 3^0-30^1

Crank movement $\frac{3^0 \frac{1}{2}}{9} = \frac{7}{18}$ i.e. 7 holes on 18 holes circle.

2. Index for 31^0-20^1

Crank movement $\frac{31^0 \frac{1}{3}}{9} = \frac{94}{3} \times \frac{1}{9} = \frac{94}{27} = 3 \frac{13}{27}$

i.e. 3 full turns and 13 holes on 27 hole circle.

3. Index for 60^0

Crank movement = $\frac{60}{9} = 6 \frac{6}{9}$ Now $\frac{6}{9} \times \frac{2}{2} = \frac{12}{18}$

Required movement = 6 full turns + 12 holes on 18 holes circle.

BROACHING MACHINES

Broaching is a machining operation in which a tool, having a series of cutting teeth, called broach, is either pulled or pushed by the broaching machine past the surface of a work piece. In doing so, each tooth of the tool takes a small cut through the metal surface. The surface to be cut may be external or internal. When the operation is performed on internal surface it is called **Internal or hole Broaching** and in case of external surface **External or surface Broaching**. Most of the cutting is done by the first and intermediate teeth, whereas the last few teeth finish the surface to the required size.

Types of Broaches: There is large variety of broaches and they are classified.

1. According to the method of operation: Push, Pull or Stationary.
2. According to the kind of operations they perform: Internal and external.
3. According to their construction: Solid, built up, rotor cut, inserted tooth, over lapping tooth, progressive etc.
4. According their use: Single purpose or Combination.
5. According to the functions: Key way, spline, burnishing, roughing, sizing, serration, rifling, surface, spiral etc.

Push broaches are shorter in length than the pull broaches, of the same cross-section in order to ensure adequate stiffness to resist bending. Push broacher is used where a shorter length is to be broached and less material is to be removed. Where a considerable amount of metal is to be removed and a longer surface is to be broached a pull type broach, which carries more number of teeth and is longer, and hence removes more material is preferred. Internal broaches are generally made of solid construction, but where chances of wear are

more and high accuracy is desired a shell type construction is always preferred, which consists of several replaceable shells mounted on a bar. They are known as built-up broaches. External or surface broaches are generally of built-up type having replaceable sections or teeth. The broaches used to produce single surface such as a round hole, are known as single purpose. Against this, many broaches, called combination broaches are designed to take two types of cuts simultaneously and produce two different surfaces or perform two different operations such as sizing and burnishing a hole or sizing a hole and cutting splines in it. Both the operations are done in a single pass of the tool. A burnishing broach is used for producing a highly finished and glazed surface. It is the tool (broach) which moves, while the work is stationary, but in certain cases the broach remains stationary, where as work pieces are moved past it as in continuous broaching machine. A broach made in single piece is known as solid broach.

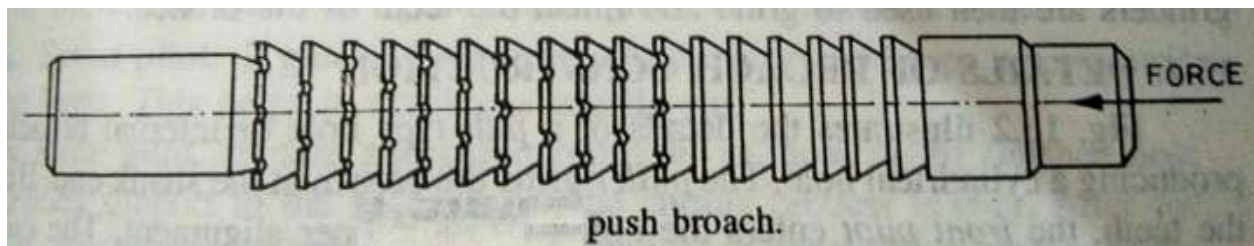

The internal broaches which are normally of solid type are commonly used for enlarging and sizing an existing hole and/or providing specific shapes to the existing holes. These holes in the components exist due to earlier operations on them, such as drilling, casting, forging, punching etc. Rotor cut broaches are used for heavy stock removal in castings and forgings.

Tool materials and Heat treatment:

For light work broaches made of high carbon steel are used. High speed steel is the most commonly used material for the manufacture of broaches and they give satisfactory performance in mass-production, and heavy duty work. They give fine surface finish and have long life. Broaches having their teeth tipped with sintered carbides used for hard materials and abrasive materials. Their use is mostly confined to mass production work in surface broaching.

Proper heat treatment and subsequent grinding are two very important aspects in manufacturing a broach. Long broaches are heated in vertical type of electric furnace, so that there is a uniform distribution of heat throughout the entire length of the tool and the distortion is minimum. This is followed by cooling in air under pressure. The broach is hung vertically during air cooling also in order to avoid war page. Short broaches are heat treated in horizontal furnaces. Specially designed grinders are used to grind and finish the teeth of the broach.

Broach Construction: The front pilot enters the hole to keep proper alignment. The cutting teeth follows the front pilot, gradually increase in size. The first set of cutting teeth, called roughing teeth, does most of the cutting. They are followed by semi-finished teeth, which remove comparatively less stock. The variation in their sizes will be smaller than the roughing teeth. They bring the size of the hole to the required size. The finishing teeth which follow after semi finish teeth do not practically remove any stock but they smooth finish the hole. When the first finishing teeth are worn out, those behind them start doing the sizing operation. The rear pilot supports the broach and keeps it aligned after the cut is over.

PRINCIPLE OF BROACHING:

The operation of broaching involves the use of a multi tooth cutter, called broach. The teeth of the broach are so designed that the height of the cutting edge of the following cutting tooth is slightly more, equal to the feed per tooth, than that of the preceding tooth. Thus when the broach is fed in a straight line, either, over an external surface or through an internal surface, the metal is cut in several successive layers by successive teeth of the broach. The thickness of each layer is same and is known as feed per tooth. The sum of thickness of all the layers taken together is called the depth of cut.

During the operation either the broaching fed past the stationary work piece or the work piece past a stationary broach, the former practice being more common. The surface produced carries an inverse profile to that of the broach teeth. A specific point regarding broaching is that out of all the basic machining processes, it is the only process in which the feed is in built in the tool (broach). This feed is equal to the chip the thickness.

A push type broach is fed past the stationary work on a horizontal broaching machine, to machine an external surface on the work piece. A pull type broach is fed in to the hallow work piece on a vertical pull-down type machine, to machine an internal surface of the work piece. In this case also, the work piece will remain stationary. Both the operations are performed in a single linear stroke of the broach. After end of the stroke in both the above operations, the broach is retraced to the original starting position, the finished part is replaced by a new work piece and the operation repeated as usual.

TYPES OF BROACHING MACHINES:

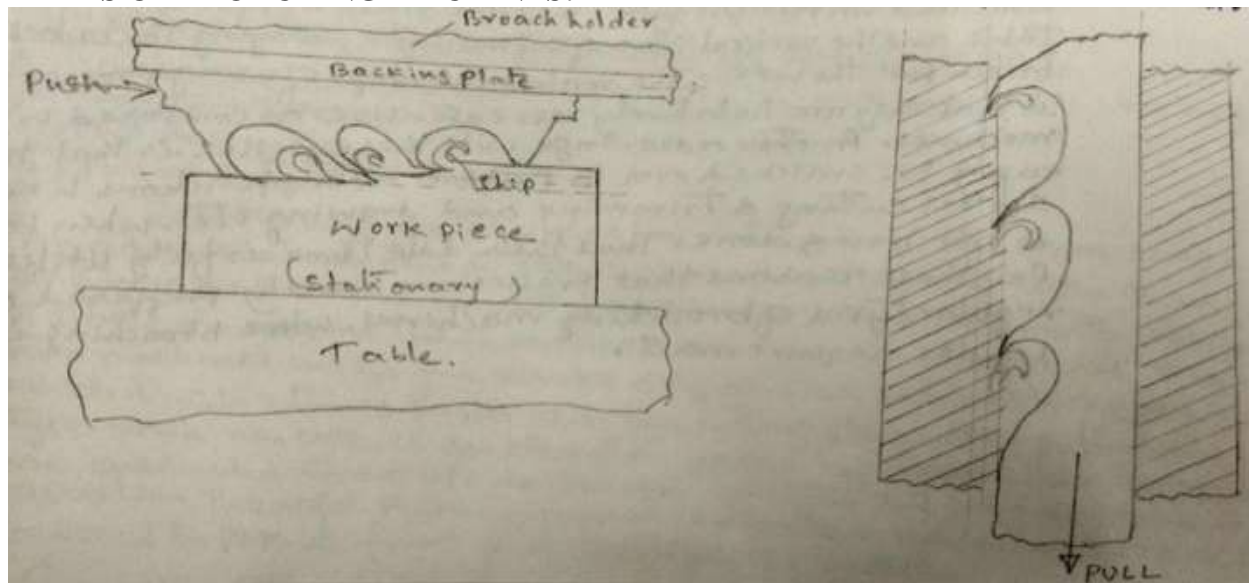

There are a number of different designs of broaching machines available in different sizes and capacities. A few of them like **arbor press** are manually operated and the rest all are operated by power. Manually operated machines are used normally where only a few pieces are required to be broached and the components are small in size. Where broaching is done on mass scale, a power driven machine is used.

The common types of broaching machines can be classified as follows:

1. According to the power employed---Manually operated or Power driven.
2. According to the direction of broach movement in cutting---Horizontal or Vertical
3. According to the method of cutting---Pull, Push or Continuous.

4. According to the condition of movement of the tool relative to the work---Moving or Stationary broach.
5. According to the type of drive---Mechanical or Hydraulic drive.
6. According to number of pull heads---Single or Multiple pull head.

Broaching Press: A small number of jobs can be easily broached on a manually operated arbor press. This is simplest and lightest of all the presses used in broaching work and is manually operated.

Modern power presses, used for broaching on mass scale, usually carry a hydraulic drive. Push type broaches are commonly used on these machines. Both internal as well as external broaching can be done, but internal broaching is more commonly performed on these machines. These machines are made in various different sizes, ranging in capacity from 250kg to 35 tons pressure. These machines are generally available in vertical type. The work piece is placed on the machine table and the vertical ram of the machine, carrying the broach, pushes the broach past the work. The main advantage of using presses for broaching is that they are relatively less expensive as compared to other broaching machines. Another advantage with these presses is that, they can easily be switched over to perform other operations like bending, swarf cutting or trimming and drawing etc, when broaching is not being done. Thus their idle time is fully utilized. It is for these reasons that presses are mostly preferred over other regular types of broaching machines, where broaching is not a regular requirement.

All the modern horizontal pull type broaching machines carry a hydraulic drive for reasons of getting the required power and efficient drive. A pressure gauge always fitted which readily indicates the pull being applied on the tool. These machines are used both for internal as well as external broaching. Those used for hole or internal broaching carry a bed quite similar to that of a lathe and the broach moves like the tail stock on the bed ways. The other class which is used for external or surface broaching, carries the guide ways on a vertical surface, normal to the bed, along which the broach moves. Fixtures are invariably used on these machines. In addition to this, the cutting pressure or to say the pull, exerted on the broach further helps in clamping the work in position. The broach is pulled by a horizontal ram, which is driven by a hydraulic piston and cylinder mechanism incorporated in the body of the machine. The mouth or front part of the ram carries a hole to receive the shank of the broach puller. The shank of the broach is passed through initial opening of the job and connected to the broach puller or pulling head. The rear end of the broach is usually held in a supporting slide, which travels along with the broach during the operation, just like a travelling steady on a lathe. These machines are manufactured in both fully automatic and semi-automatic types. In both the type's automatic stops and limit switches are provided to control the length of stroke of the ram.

Vertical Pull Type Broaching Machine: Vertical broaching machines, using the method of pull-broaching, are of two types:

1. Pull - Down Type.
2. Pull - Up Type.

Both these types are used for internal or hole broaching, an additional advantage with these machines is that more than one broache can be mounted and made to operate simultaneously. A single ram sometimes carries as many as four broaches. Single ram machines cut in one stroke only and the return stroke is idle, which is 2 to 3 times faster than the cutting stroke.

The Pull-Down type machine carries an elevator at the top from which the broaches are suspended in an upside position, the tail being gripped in the elevator. The work piece is mounted over the table and broach lowered to pass its front pilot through the work.

This pilot is gripped by the pulling head attached to the top of the ram, which is enclosed in the bed. The ram pulls the broach down through the work piece to produce the desired hole. After the cut is over the work piece is removed and the broach pushed up by the ram, so that the elevator again grips the rear end of the broach to take it back to the starting position. The work piece is removed and a fresh work piece loaded to start the next operation.

In pull-up type machine the ram is provided at the top, which carries the pulling heads at its bottom. The elevators are provided inside the bed to hold the broach in vertical position. The work piece is clamped to the underside of the table and the elevators raised to pass the front pilots of the broaches through the work piece and the table where they are gripped by the pulling head. The ram, then, starts its upward or cutting stroke and pulls-up broach through the work piece. After the end of the stroke the work piece falls down and is removed and the ram lowered. The rear ends of the broaches are again gripped by the elevators and the ram is brought down to the starting position.

Duplex-Head Broaching Machines: these machines carry two rams instead of one. They are made in both horizontal type as well as vertical type. These machines give very fast rate of production as they provide a sort of continuous cutting in the sense that when one broach is providing the cutting action the second one is returning to the starting position and vice-versa. These machines use push method of broaching and are commonly used for external or surface broaching. Something happens in case of loading and unloading of the jobs that while one fixture is being unloaded and reloaded with fresh job the other is holding the other job in operation and vice-versa.

Continuous Broaching Machines: these machines are manufactured in both horizontal as well as vertical type. Horizontal machine mainly differs from other types in that the broach remains stationary while the work pieces move continuously past it to perform the cutting. The horizontal machine consists of two sprockets, one on each side of the machine, on which continuously travels an endless chain. A series of fixtures are mounted on this chain to travel along with it. The broaches are rigidly held on the machine in horizontal position over the chain. Work pieces are loaded on the fixtures on one side of the machine and unloaded on the other side. The speed at which the parts can be broached depends upon how fast the loading of work pieces is done. The vertical type carries a number of platens on a continuous chain. Broach holders are mounted on these platens to carry the broach sections. The work is clamped on the horizontal table of the machine and the broach sections moved past the work by moving the chain.

Another useful type of continuous broaching machine is the **Rotary table Horizontal Continuous Broaching** machine. In this machine a rotary type of table continuously rotates about axis. The fixtures are mounted on this table. The broach is held rigidly on the broach holder above the table. The body of the broach also carries a curvature similar to that of the table. Work pieces are loaded in the fixtures. As the table rotates at a slow speed, the work pieces are fed past the stationary broach and the finished pieces unloaded, followed by loading the fixtures with fresh work pieces. Thus the cycle of loading, broaching, unloading and reloading continues without any break. These machines are very useful in mass production of identical broached components.

Machine Size: The size of the broaching machine is the length of stroke of ram in mm and the pressure applied on the broach in kgs or tons. The other main specifications of the machine are:

1. Range of speeds and feeds.
2. Type of drive.
3. Power rating of electrical motors.

1. Internal or Hole Broaching: In this, normally the work remains stationary and the broach is either pushed or pulled through the same to produce a hole of desired shape and size.

2. External or Surface Broaching: In this either the work or the broach is moved past the other to produce a groove or surface of desired shape and size on the external surface of the work.

3. Pull Broaching: Mostly adopted for internal broaching. In this, the work remains stationary and the broach is pulled through the same to produce the hole of desired shape and size.

4. Push Broaching: Adopted mostly for internal broaching of relatively lighter jobs. The work piece remains stationary and the broach is pushed through the same. However, it can be used for external broaching also.

5. Continuous Broaching: It is a method suitable and largely adopted for broaching of identical components on large scale. In this method, the broach remains stationary, while the work pieces move continuously past the same along a horizontal or circular path.

Broaching Speeds: Broaching operation uses lower cutting speeds. Selection of proper speed for broaching a particular component will be decided by the following factors:

1. Hardness of work piece material.
2. Length of broaching.
3. Type of material to be broached.
4. Rigidity of the component to be broached.
5. Economic considerations for the operation.

Broaching speeds for some common materials are

Carbon Steel --- 3 to 8m/min

Cast Iron --- 6 to 30 m/min

Copper Alloys --- 8 to 10 m/min

Free Machining Steel --- 10 to 12 m/min

Machining Time

In broaching operation the machining time depends on effective length of broach i.e. the length of tooth system of the broach. It is given by the following relation.

$$\begin{aligned} \text{Machining Time} &= \frac{\text{Effective length of broach in meters}}{\text{Cutting speed in m/min}} \\ &= \frac{\text{Effective length in mm}}{1000 \times \text{cutting speed in m/min}} \end{aligned}$$

Broaching versus other Machining operations: Merits

1. Broaching is faster than other machining operations.
2. It enables a higher rate of production, more accuracy, and better finish than other operations.

3. Since each tooth of broach takes a small cut that too only once in one operation, it has longer life than other cutting tools.
4. Owing to the above reason, the tool cost per work piece is low.
5. A single tool (broach) performs both roughing and finishing operations.
6. Better surface finish is obtained because different teeth perform different operation.
7. Cutting fluid can be applied more easily and effectively than other operations.
8. Because of simplicity of machining cycle, it does not required highly skilled operator.
9. Interchangeable components can be produced at a much faster rate by broaching than any other operation.
10. A specific advantage in broaching is that the cutting force of the broach serves to clamp the work piece and hold it firmly in position.

1. It is a single purpose tool and can produce only one type of surface.
2. The initial cost of the tool is very high compared to other tools.
3. It is unsuitable for small quantity and are of variable sizes.
4. All the jobs in broaching will need fixtures and this will add to the cost.
5. The broaching machine is costly of all machine tools its existence will not be justified unless production required is very high.
6. Tool sharpening is difficult and expensive, needs separate sharpening machine.
7. All types of surfaces can't be machined through broaching.
8. Very light and delicate jobs cannot be broached easily, as they can't with stand the cutting force.
9. Surfaces which lie in separate planes can't be machined in single setting.
10. Blind holes cannot be easily produced through broaching.

Broaching applications:

A wide variety of shapes, internal, external, regular, irregular, including complex contours can be produced through broaching. Several shapes which are difficult to be machined on the other machine tools can be easily machined through broaching.

Broaching applications include the machining of bearing caps, bearing bodies, cylinder blocks, connecting rods, cylinder heads, crank cases, rotors, toothed sprockets for chain drives, gears, turbine blades, sleeves, bushings and air craft engine parts etc.

GRINDING MACHINE

Grinding is a process of removing material by the abrasive action of a revolving wheel on the surface of a work piece, in order to bring it to the required shape and size. Grinding is similar to other machining operations since the material is removed in the form of very small chips, similar to those obtained in other machining operations. The wheel used for performing the grinding operation is known as "Grinding Wheel". It consists of sharp crystals, called abrasives, held together by a binding material or bond .It may be a single piece type or several segments joined together. In most of the cases, it is a finishing operation and a very small amount of material is removed from the surface during the operation

ABRASIVES: It is the material of the grinding wheel, which does cutting action. These are extremely hard materials, consisting of very small particles, called grains, which carry a number of sharp cutting edges and corners. They are two types. 1). Natural 2).

Artificial

Natural Abrasives: They are obtained directly from mines. The common natural abrasives are sand stone, emery, corundum, Quartz and diamond.

All the natural abrasives, except diamond are now obsolete. Sand stone is used only for sharpening wood working tools. All other natural abrasives are almost replaced by artificial abrasives. Diamond, still retains its place even in modern grinding processes. It is largely used for dressing grinding wheels and for grinding hard materials.

Artificial Abrasives: They are manufactured under controlled conditions in closed electric furnaces to avoid impurities and to achieve necessary temperature for the chemical reaction to take place. The main artificial abrasives are:

1. Silicon Carbide (Sic): It is made from Silicon dioxide, coke, sawdust and salt. These constituents are mixed together and piled up around carbon electrical conductor of a resistance type electric furnace. A heavy current is switched on and temperature of about 2600°C generated. The mass, under the action of intense heat, fuses. The outer shell is removed and the Silicon Carbide Crystals are broken in to grains.

2. Aluminum Oxide: This abrasive is very hard and tough grains having sharp cutting edges. It is obtained by fusing impure Aluminum Oxide (Bauxite) in an electric arc furnace. Dry bauxite is mixed with ground coke and Iron chips. This mixture is heated in the furnace with a heavy current. It is then crushed and the powdered grains are formed are screened through standard meshes. These grains are not as hard as Silicon Carbide but less brittle preferred for grinding metals of high tensile strength like hardened tool steel components.

3. Artificial Diamonds: The diamonds produced through artificial means are quite comparable to the natural diamonds in their grinding characteristics and give normally better results than the natural diamonds.

Advantages and uses of artificial abrasives

The manufactured or artificial abrasives superseded the natural abrasives for the following reasons:

1. The controlled conditions in the electric furnace enable uniformity in the product.
2. The quantity of production and supply can easily be varied according to the demands.
3. They have largely abolished the dependence on natural means to meet the growing demand in the modern manufacturing processes.

The selection of a particular abrasive is governed by many factors, like hardness, toughness and other properties of work material.

BOND MATERIALS:

In order to give an effective and continuous cutting action, it is necessary that the grains of abrasive material should be held firmly together to form a series of cutting edges. The material used for holding them is known as bond. The principal bonds are:

1. Vitrified
2. Silicate
3. Oxychloride
4. Resinoid
5. Shellac
6. Rubber

1. Vitrified bond: It is a clay bond, reddish brown color. The base material is “Felspar” which is fusible clay. Proper proportions of Felspar, refractories and flux mixed thoroughly with abrasive grains to form a paste. The paste is placed in moulds to get the shape of a wheel

and air dried. The wheels become enough hard are fed in to kiln at 1260°C and allowed to remain there for few days. This process is known as fusing and it provides uniform distribution of bond through and the wheel. After this, the wheels are trimmed to the required size. For obtaining very hard and close grained wheels, the paste after being place in the moulds, is pressed under hydraulic pressure.

Advantages:

1. It is made porous and enables quicker metal removes.
2. It is not affected by water, oil, acids, temperature or climatic conditions.
3. The bond itself is very hard and acts as an abrasive.
4. On account of excessive heat in the kiln the impurities are burnt and only bond and abrasive left.
5. The structure of the wheel is uniform due to wet mixing of different constituents.

Disadvantages:

1. The process of manufacture is very slow.
2. Cracks may develop in large size wheels during fusing.
3. Wheels over 750mm dia can't be easily produced.
4. Proper control during fusing becomes difficult.
5. High temperature in kiln tends to make the abrasive grains weak.

2. Silicate bond: Its base material is Silicate of soda. The process of mixing, moulding, packing or ramming, drying etc are done in the same way as vitrified bond, but the oven carries a temperature of about 260°C only. The application of lower temperature results in high tensile strength. As usual, the paste mixture after moulding is subjected to hydraulic pressure if hard and close grained wheels are needed. They are light grey in color. These wheels are used where a cool cutting action with less wear is needed as in grinding the edges of the heat treated steel cutting tools. The cool cutting action is due to the bond releases the abrasive grains more quickly than vitrified bond.

1. It is more rapid process than vitrified bond.
2. Because of the moderate temperature in kiln, there is no tendency to weaken the grains.
3. Fusing is better controlled, results in more reliable bond.
4. When wet grinding is performed, the soda acts as a lubricant.
5. Large wheels up to 1500mm dia can be easily produced.
6. The cutting action of the wheel is smoother and cooler.
7. Because of low fusing temperature the wheel can be moulded on Iron backs, which is not possible in case of vitrified bond.

1. Extra hard wheels cannot be produced with this bond.
2. Harder grades of this bond do not provide a free cutting action.

3. Oxchloride bond: It is a mixture of Oxide and Chloride of Magnesium and setting takes place in cold state. The process of wheel manufacture is similar to the above two, but no heating and subsequent cooling is required on account of the cold setting property. Ageing is necessary so that the bonded wheel gets adequate hardness. This bond provided a cool cutting action, but grinding is usually done dry as it is very susceptible to the action of conventional coolants and therefore, the full use of the cutting capability of the wheel cannot be taken.

4. Resinoid bond: It is a synthetic organic compound, which is enough strong and flexible. It provides a sharp cutting action and enables a high rate of stock removal at high speeds. Mainly used for cutting bar stocks, fine grinding of cams, precision grinding of rolls etc.

These wheels are manufactured from a mixture of abrasive grains, synthetic resins and some compounds. This mixture is filled in moulds and then fed in to the furnace for heating. A constant temperature of about 2000 °C is maintained in the furnace. Due to heat, the resin sets and binds the abrasive grains together. The shape and size of the bonded wheels will depend upon the shape and size of the mould.

5. Shellac bond: These wheels are produced by mixing the bond and the abrasive grain in a steam heated mixer, followed by moulding under pressure in steam heated moulds. These wheels are cool cutting and are vastly used on hardened tool steel and thin sections. They also help in producing high surface finish, as is normally required on components like cam shafts. They can run safely in water but use of oil or caustic soda should be avoided.

6. Rubber bond: It is composed of fairly hard vulcanized rubber. The common manufacturing process consists of passing of rubber and sulphur through the mixing rolls and adding the abrasive grains slowly as the above two constituents pass through the rolls. Adding of abrasive grains continues till the required proportion is achieved. The mixture is then passed through another set of rolls to obtain the required thickness. The wheels are then cut and placed in preheated moulds and vulcanized under pressure. These wheels are quite strong, close grained and can be made in very thin sections. They are mainly used where a very high class surface finish with close dimensional accuracy is required. During the operation water can be safely used as a coolant, but caustic soda and oil should not be used as caustic soda will disintegrate the bond and the oil will soften it.

Symbols used for representing the type of bond.

Vitrified	_____	V
Silicate	_____	S
Oxychloride	_____	O
Resinoid	_____	B
Shellac	_____	E
Rubber	_____	R

SELECTION OF GRINDING WHEELS

Selection of proper grinding wheel is a vital necessity to obtain the best results in grinding work. A wheel may be required to perform various different functions like quick removal of stock material, give a high grade surface finish, maintain close dimensional tolerances and a single wheel will fail to meet all the requirements. It is necessary therefore, that proper grain size, bond, grade, strength, shape and size of the wheel should be selected to meet the specific requirements of a job. The factors upon which the above selection will depend are as follows:

1. Properties of the material to be machined i.e. its hardness, toughness, strength etc.
2. Quality of surface finish required.
3. Grinding allowance provided on the work piece i.e. the amount of the stock material to be removed.
4. Dimensional accuracy required.
5. Method of grinding i.e. wet or dry.
6. Rigidity, size and type of machine.
7. Relative sizes of wheel and job.

8. Type of grinding to be done.
9. Speed and feed of the wheel.

TYPES OF GRINDING MACHINES

Different types of grinding machines have been designed and are being used. Some of these are for roughing work, some for precision work and some for special purpose i.e. to perform a specific type of operation only. There are many varieties of grinding machines; the most commonly used types can be classified as:

1. Roughing or non precision grinders.
2. Precision grinders.

1. Roughing or non Precision grinders: The main purpose of these grinders is to remove more stock than can be removed by other types of grinders. The quality of surface finish is of secondary importance are as follows:

1. Bench, pedestal or floor grinders.
2. Swing frame grinders.
3. Portable and flexible shaft grinders.
4. Belt grinders.

1. Bench, pedestal or floor grinders:

These grinders are commonly used for grinding various materials and cutting tools in tool rooms, foundries and general repair shops etc. They carry horizontal spindle, having grinding wheels mounted on both ends. It can be suitably bolted on a bench.

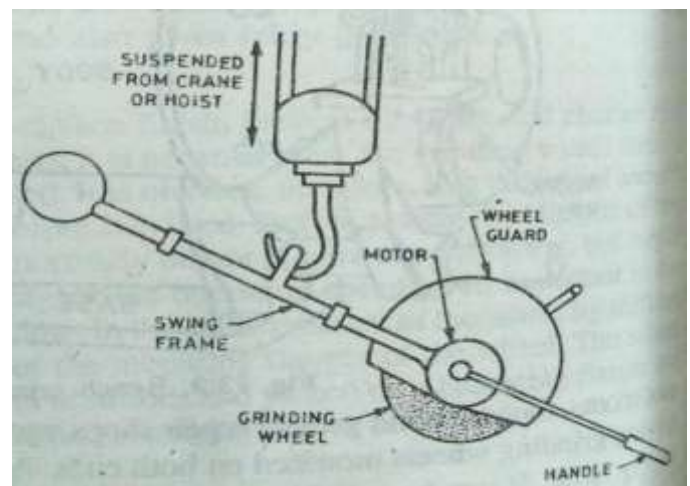

The floor stand or pedestal grinder is bench grinder of above type mounted on a steel stand or pedestal of suitable height. The horizontal spindle carrying the grinding wheels is normally an extension on both sides of the armature shaft of the motor. These grinders can also be used for polishing by replacing the grinding wheels by polishing wheels.

2. Swing frame grinders: It consists of a 2 to 4 meters long horizontal frame, freely suspended at its centre. The frame carries a grinding wheel at its one end and motor at the other. The motor drives the grinding wheel by means of a belt. In operation, the motor is started to revolve the wheel and the frame swung by the operator about its point of suspension (centre point) to cover up the desired grinding area.

3. Portable and flexible shaft grinders: These grinders resemble very much with the portable electric drills, both in construction, as well as operation, with only difference that the spindle carrying the drill chuck is replaced by a spindle on which a small grinding wheel is mounted. A safety guard is also provided over the wheel. These grinders are vastly used in finishing casting, forgings, welded joints in structural work, removing burrs and sharp edges.

Flexible shaft grinders consist of a flexible shaft driven by an electric motor. The shaft carries a chuck or collet at its end to receive small grinding tools, mounted wheels and points and small grinding discs. The electric motor is mounted on a fixed stand.

4. Belt grinders: These machines are designed to use an endless abrasive belt for grinding instead of a regular type of grinding wheel. The belt runs round the pulleys or rollers and the work is fed against the revolving the abrasive coated belt. One of the rollers (driver) revolves at high speed. A heavy metal plate called platen is so incorporated that the smooth under side of the belt runs in contact with the same. This platen may carry the shape conforming to the shape of an object or may be flat as required. The work piece is fed manually on to the open abrasive side of the belt and pressed against the platen to perform the grinding operation.

With proper selection of proper grade and grit size, this process can be used both for rough and finish grinding. Machines are available in different varieties like wet-belt, dry-belt, combination machines etc.

CYLINDRICAL GRINDERS

The principle of cylindrical grinding involves holding the work piece rigidly on centers in a chuck or in a suitable holding fixture, rotating it about its axis and feeding a fast revolving grinding wheel against the work. If the work surface to be ground is longer than the face width of the grinding wheel, the work is traversed past the wheel or the wheel past the

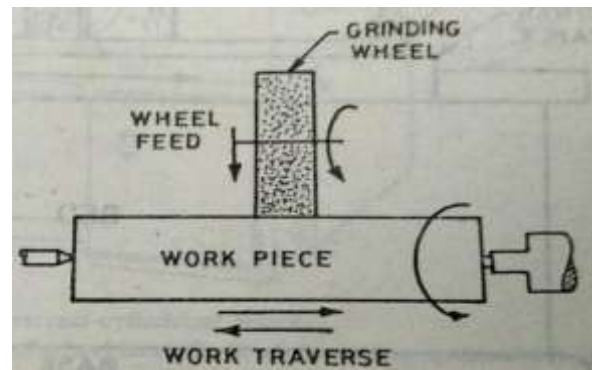

work. Traversing of wheel or work is done either by hydraulic or mechanical power or by hand. Feed is given to the work or the wheel at the end of each traversing movement. In case the width of wheel face is more or equal to the length of the work surface to be ground, the wheel may be fed in with no traversing movement of it or that of the work. This is known as “**Plunge Grinding**”. The simplest and commonly used type of cylindrical grinder is a tool post grinder used on lathes. When wheels of large diameters are used, they can be mounted directly on the motor shaft. For mounting small wheels an auxiliary shaft is provided, which runs at a relatively much higher speed than the motor. Both external and internal cylindrical grinding can be done on lathe by this equipment.

Cylindrical grinding machines are mainly of the following three types:

1. Plain Cylindrical Grinders.
2. Universal Cylindrical Grinders.
3. Centre less Grinders.

1. PLAIN CYLINDRICAL GRINDERS: On these grinders, the work piece is usually held between two centers. One of these centers is in the head stock and the other in the tail stock. In operation, the rotating work is traversed across the face of the rotating grinding wheel. At the end of each traverse, the wheel is fed in to the work by an amount equal to the depth of cut. While mounting the work between centers, the head stock centre is not disturbed. It is the tail stock centre which is moved in or out, manually or hydraulically, to insert and hold the work. Tail stock and head stock both can be moved along the table to suit the work. The table is usually made in two parts. The upper table carries the tail stock, head stock and the work piece and can be swiveled in horizontal plane, to a maximum of 10^0 on either side along the circular ways provided on the lower table. This enables the grinding of tapered surfaces. The lower table is mounted over horizontal guide ways to provide longitudinal traverse to the upper table, and hence the work. The table movements can be both by hand as well as power. Hydraulic table drives are usually preferred.

The wheel head is usually mounted on horizontal cross ways on the bed and travels along these to feed the wheel to the work. This movement is known as in feed. The wheel and work are so adjusted that the grinding force is directed downwards to ensure proper stability.

UNIVERSAL CYLINDRICAL GRINDERS: A universal cylindrical grinder carries all the parts and movements of a plain cylindrical and in addition, carries the following advantageous features:

1. The head stock can be made to carry alive or dead spindle, as desired, the former (live centre) being needed, when the work is held in a chuck.

2. The head stock can itself be swiveled in a horizontal plane.
3. Its wheel head can be raised or lowered and can also be swiveled to $\pm 90^0$ to grind tapered surface having large taper angles.

All these factors contribute towards the greater versatility of these grinders. All the modern universal type cylindrical grinders carry hydraulic drive for wheel head approach and feed, table traverse and elimination of back lash in the feed screw nut. Most of the modern universal grinders are provided with necessary extra equipment like work rest to support slender work, wheel truing device, arbor for balancing the wheel, internal grinding spindle and three jaw self centering chuck etc.

3. CENTRELESS GRINDERS: These grinders are also a type of cylindrical grinders only, but the principle of centre less grinding differs from centre type grinding in that the work, instead of being mounted between centers, is supported by a combination of a grinding wheel, a regulating wheel and a work rest blade. The relative movements of the work piece and two wheels, the principle of centre less grinding is used for both the external as well as internal grinding. Many hollow cylindrical and tapered work pieces, like bushes, pistons, valves tubes and balls etc, which either do not or cannot have centers, are best ground on centre less grinders.

It carries a heavy base and two wheel heads, one carrying the grinding wheel (larger one) and the other regulating wheel (smaller one). The work piece rests on the blade of the work rest between these two wheels. Each head carries a separate wheel truing mechanism for the wheel it carries. Housing is provided on one side of the machine body to house the main driving motor. There are two control panels on the front. The left hand panel carries controls for speed adjustments of the two truing mechanisms and the in feed grinding mechanism. The right hand panel carries controls for hydraulic mechanism speed adjustment of regulating wheel, automatic working cycle switch, start and stop switches etc.

In operation, grinding operation is performed by the grinding wheel only while the function of the regulating wheel is to provide the required support to the work piece while it is pushed away by the cutting pressure of the grinding wheel. At the same time, required support from bottom is provided by the work rest as the work piece, while rotating rests on the blade of the work rest. The regulating wheel essentially carries rubber bond and helps in the rotation of the work piece due to friction. The directions of rotation of the two wheels are the same. The common methods used feeding the work is:

1. Through feed
2. In feed
3. End feed

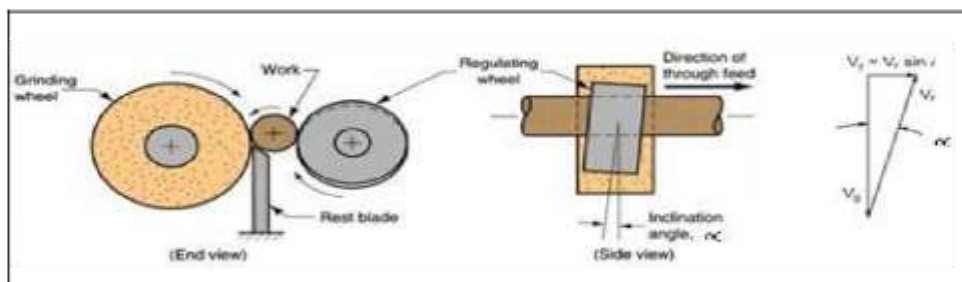

1. Through feed Grinding: In this method of centre less grinding, the work piece is supported and revolved as described above but is simultaneously given an axial movement also by

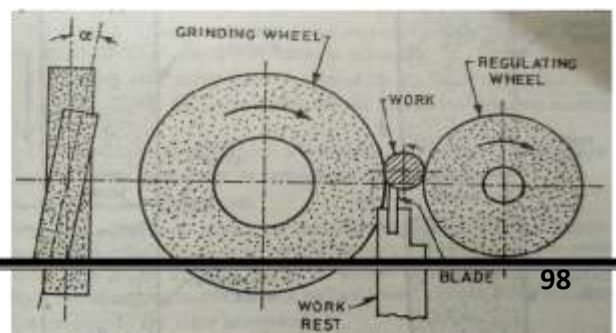

the regulating wheel and guides so as to pass between the wheels. For this, the axis of the regulating wheel is inclined at 2° to 10° with the vertical. The amount of the stock to be removed determines as to how many times a work piece has to pass between the wheels. This method is used for straight cylindrical objects.

The actual feed (f) can be determined by the following relationship:

$$f = \pi d n \sin \alpha$$

Where f = feed in mm/min

d = dia. of regulating wheel in mm

n = Revolutions/min

α = Angle of inclination of regulating wheel

2. In feed Grinding: Both regulating wheel and grinding wheel are more in width than the work length to be ground. Axis of the regulating wheel is inclined about half a degree from the horizontal. This method is used for grinding shouldered or formed components.

Before the operation, the regulating wheel is drawn away to accommodate the work piece. After placing the work piece on the blade of the work rest, the regulating wheel is again pushed in to press against the work. In this operation, the work rest does not carry guides. Instead, it is made to have an end stop at the rear end.

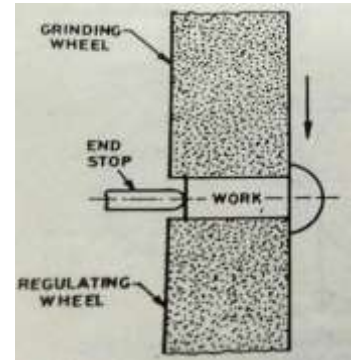

4. **End feed Grinding:** This method, in a way, a sort of form grinding. It is because both the wheels i.e. the grinding wheel and regulating wheel, are dressed to contain the required shape or form. The work is fed longitudinally from the side of the wheels. As it advances between the revolving wheels, its surface is ground till its farther end touches the end stop. This method can be used for grinding of both spherical and tapered surfaces, but it suits best to the grinding of short tapered surfaces.

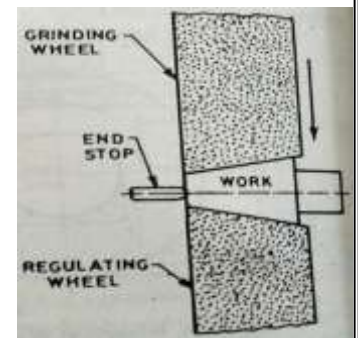

Advantages of centre less Grinding:

1. Need for centering and use of fixtures etc is totally avoided.
2. It can be applied equally to both external and internal grinding.
3. Once a set up has been made, it is a faster method than centre type grinding
4. In feed method also no chucking of work is needed and idle time is negligible.
5. Since there is no end thrust, there is no any spring action or distortions in long work pieces.
6. The work is rigidity supported during the operation, heavy cuts can be taken, rapid & economical.
7. Making and making of centre holes totally eliminated and smaller grinding allowance, less time.
8. Large grinding wheels are used and errors due to wheel wear are reduced.
9. Very little maintenance is needed for the machine.
10. Very high skilled operators are not needed.
11. Direct adjustment for sizes can be made, resulting in high accuracy.
12. A fairly wide range of components can be ground.

SURFACE GRINDERS:

Surface grinders do almost the same operation as the planers, shapers or milling machines, but with more precision. Primarily they are intended to machine flat surfaces, although irregular, curved or tapered surfaces can also be ground on them. The common classification of surface grinders can be made as follows:

1. According to the table movement:
 - a) Reciprocating Table Type.
 - b) Rotary Table Type
2. According to the direction of wheel spindles:
 - a) Vertical Spindle Type.
 - b) Horizontal Spindle Type.
3. Special type and single purpose machines.
 - a) Face Grinders.
 - b) Way Grinders.
 - c) Wet Belt Grinders.

Reciprocating table type Surface Grinders:

A reciprocating table type surface grinder may have a horizontal spindle of the grinding wheel, or a vertical spindle of the same. The horizontal spindle carries a straight wheel and the vertical spindle a cup type wheel. Hydraulic drives are commonly used in all such grinders. Cutting is done on the periphery of the straight wheel, in case of horizontal type and on the revolving edge of the cup wheel on vertical spindle machines. The horizontal spindles are widely used in tool rooms. The work piece is held on a magnetic chuck on these machines. They are vastly used for grinding flat surfaces. The machine size is designated by the dimensions of the working area of the table.

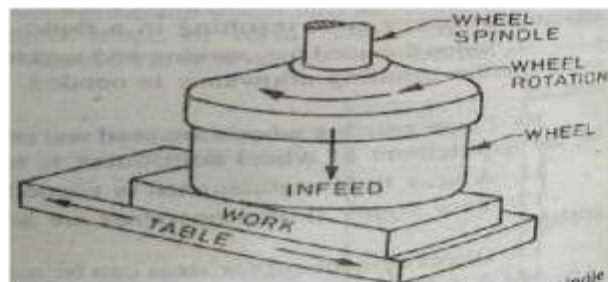
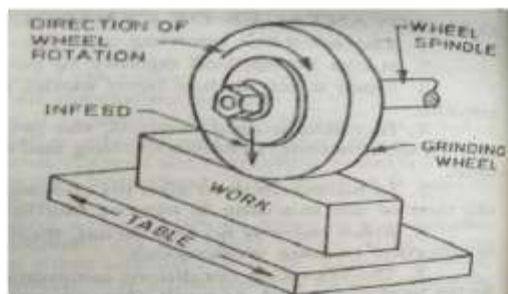

The longitudinal feed to the work is given by reciprocating the table. Forgive cross feed, there are two methods. One is to mount the table on a saddle and give the cross feed by moving the saddle. Alternatively, the cross feed can be given by moving the wheel head in and out. In feed is provided by lowering the wheel head along the column.

In case of vertical spindle reciprocating table grinders the table along with work piece, reciprocates under the wheel. The wheel covers all or a major portion of the width of the job. Cross feed to the work can be given by moving the saddle. A manual or power feed can be used to feed the wheel head vertically. An individual motor drive is provided to rotate the wheel.

Rotary table Surface Grinders:

Rotary table surface grinders are also made in two types. i.e. either having horizontal wheel spindle or a vertical wheel spindle. A circular shaped magnetic chuck is mounted on the circular table to hold the jobs. The work pieces are normally arranged in a circle, concentric with the round chuck. If it is a single piece, it

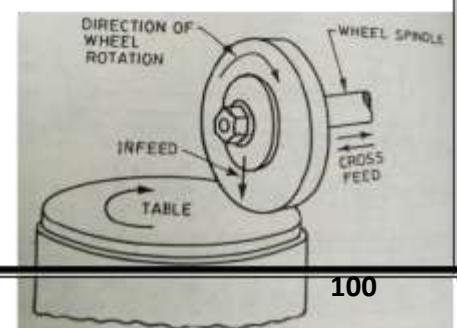

can be mounted centrally on the chuck. The table is made to rotate under the revolving wheel, both rotating in opposite directions.

The vertical feed to the wheel is given by moving the wheel head along a column and the cross feed by the horizontal movement of the wheel spindle. A straight wheel is used on these machines, which cuts on its periphery. Some machines carry the provision to raise or lower the table also and also to incline the same.

A cup wheel has to be used on these machines. Vertical feed to the wheel is given by moving the wheel head. The work pieces are mounted on the round chuck in same way as in the horizontal spindle type. The table rotates in a direction opposite to that of the wheel and brings the work pieces one after the other under the rotating wheel. The table is mounted on a slide, so as to give cross feed. Some rotary table surface grinders are provided with two tables instead of one, so that, while the work pieces are being ground on one table, the other table can be used for loading the fresh batch of work pieces.

OTHER TYPES OF SURFACE GRINDERS

1. Face Grinder: It is similar in operation to a horizontal spindle reciprocating table surface grinder, but differs in that a vertical flat surface is ground instead of a horizontal one. The cutting is done on the face of the wheel and not on the periphery. Cup ring or segmental type wheels are used, which are mounted on a horizontal spindle and fed on to the vertical surface of the work piece, mounted on the reciprocating table. This type of the machine is used for large and heavy work pieces.

2. Way Grinder: It is a single purpose machine used for grinding the bed ways of different machines. It is a very large and heavy duty machine carrying a vertical spindle. Cup, ring or segmental type wheels are used on this machine. The wheel spindle can be tilted to a desired angle to grind inclined the work past the rotating wheel.

3. Wet Belt Grinders: These machines carry a vertical platen, which supports an endless abrasive belt revolving in a vertical direction. The table moves to feed the work against the belt and the table oscillates across the belt to effect desired grinding. The abrasive used on the belt carries the resinoid bond. This type of machine is specially used in grinding low fusion point materials as a large amount of heat generated is absorbed by the coolant, which is used in ample quantity.

TOOL AND CUTTER GRINDING MACHINES

These machines are primarily intended for tool room work for grinding cylindrical and tapered multi tooth cutting tools, like milling cutters, hobs, drills, reamers, taps, broaches, gear shaper cutters etc.

They are also capable of doing light cylindrical, surface and internal grinding operations. They are made in various different designs. The most versatile and widely used form is a universal tool and cutter grinder.

It carries a work head and tail stock on an upper table, which is mounted on a lower table on which the upper table can be swiveled to grind the tapered tools. The saddle travels in cross direction. The saddle and table travels are controlled by hand. The wheel head is rigidly mounted on an elevating column and consists of a housing carrying a wheel spindle, which runs in two bearings. Both ends of the spindle are tapered to receive the clamping sleeves, carrying the grinding wheels. The wheel heads can be swiveled about a vertical axis together with the column and its driving motor. These grinders largely owe their high versatility to the large number of attachments they carry. A few main of these are:

1. Universal work head.

2. Wheel dressing device.
3. External cylindrical grinding attachment.
4. Swiveling vice.
5. Internal grinding attachment.
6. Core drill grinding attachment.
7. Tap grinding attachment.
8. Face milling cutter grinding attachment.
9. Long reamer grinding attachment.
10. Form cutters grinding attachment.
11. Universal tooth rest.
12. . Gear shaper cutters grinding attachment.
13. Hob grinding attachment.
14. Twist drill grinding attachment.

Other tool grinders include the profile or contour grinder and moonset tool and cutter grinder. The former is used to reproduce a template form on a flat or round cutter. The latter is mainly used in grinding spiral fluted cutters and twist drills. Carbide tool grinder is used for grinding various angles on single point tools, mainly carbide tipped tools.

SPECIAL TYPES OF GRINDING MACHINES:

These machines are designed to do some specialized operations. Some common types of these machines are the following:

1. Roll Grinders.
2. Cam shaft Grinders.
3. Disc Grinders.
4. Crank shaft Grinders.
5. Piston Grinders.
6. Thread Grinders.
7. Tool post Grinders.

1. Roll Grinders: These are very heavy duty types of plain cylindrical grinders. They carry all the features of plain cylindrical grinder, but are made relatively heavier and more rigid. Normally roll grinders do not carry any provision for grinding the tapered work, but some carry, a set over type tail stock, similar to that used on a lathe, in order to deal with such type of work. The main use of these grinders is in grinding various types of heavy cylinders, like hydraulic rams, turbine shafts and rolls used in various industries like paper mills, steel mills, textile mills, printing presses, rubber industries and flour mills etc.

The specific equipment of these machines includes the journal rests and a cambering device. The journal rests are used to receive the previously turned journals of the rolls and support the rotating rolls on them during the operation. The cambering device is a special attachment used for crowning or cambering the rolls at the centre. The term crowning has similar meaning here also as applied to the pulleys. It means, increasing the size of the roll at its centre as compared to the dimensions at the ends. A reverse of it is called cambering. Rolls used in cold working of metals are crowned, as they are likely to be subjected to heavy forces. Against this, the rolls which work on hot metal are cambered as they are likely to expand more at the centre than the ends during hot working. The above features in the rolls neutralize the bad effects of cold and hot working and enables the products to have a uniform thickness. A common type of cambering and crowing attachment involves the use of a cam

which works in conjunction with the table traverse to direct the grinding wheel in or out to produce the desired curvature at the centre.

2. Cam Shaft Grinders: It is a special type of cylindrical grinder. In this, the work piece is mounted between the centers. A separate base is provided, which carries the tail stock and head stock and the complete unit can oscillate about a centre below the work piece. A template, which is a small facsimile of the cam shaft, is mounted on the head stock. It rotates along with the cam shaft to be ground and actuates a hardened steel roller, which makes the whole unit to oscillate in and out to produce the desired shape. The work revolves very slowly. All such machines are made automatic.

3. Disc Grinders: The operation of disc grinding is used for large scale grinding of flat surfaces. A surface grinder does the same work, with more close dimensional tolerances, but a disc grinder does it more rapidly. The abrasive discs used in disc grinding are fairly large in size and less in thickness as compared to the standard grinding wheels. As such they are backed by steel plates to withstand the grinding pressure. The main reason for faster grinding is that the discs present more abrasive area to the work than the wheels.

The main types of disc grinders are the single and double spindle. Single spindle grinders are used for off-hand grinding and double spindle for grinding both sides of the work simultaneously. The size of the machine is designated by the diameter of the disc it uses. Some machines carry horizontal spindles and some others vertical spindles.

4. Crank Shaft Grinder: These machines are basically cylindrical grinders, involving the principle of plunge cut grinding, for grinding of crank shafts for different types of automobiles and air craft engines, compressors etc. With large scale increase in the use of automobiles, engines, pumps etc. the use of these machines has also considerably increased in the country.

Main parts of a crank shaft grinder:

The machine consists of the following principal units:

1. Bed
2. Table
3. Hydraulic system
4. wheel head
5. wheel head spindle cross feed and axial movement mechanisms
6. table hand traverse mechanisms
7. head stock
8. tail stock
9. coolant system and
10. Electricals

5. Piston Grinders: A majority of pistons used in I.C. Engines are not of true cylindrical shape. Most of these pistons carry slightly elliptical outer surface. At times, the outer surface may be slightly tapered also. The grinders used in grinding of these pistons, therefore, carry suitable mechanism to automatically regulate and synchronize the inward and out ward movements of the revolving piston and the cutter feed in such a way that the required type of outer surface is ground on the piston together with taper, if desired.

6. Thread Grinders: Thread grinding is basically, a generating process, in which the desired thread profile is generated on a solid cylindrical object through grinding. The machines used

in this process operate on the principle of cylindrical grinders. These machines carry a lead screw which is connected to the head stock, in the same way as in a centre lathe, in order to establish a definite ratio between the speed of rotation of the work and the longitudinal traverse of the grinding wheel. Thus the grinding wheel, which is given the shape of thread profile on its face, follows the desired helix path similar to a single point thread cutting tool on a lathe. The helix angle is provided to the grinding wheel by tilting its spindle to the required angle.

If the thread length is small, a better and quicker alternative to the above method is plunge cut grinding. In this, the cylindrical grinding wheel chosen should have its face wider than the length of the threads. The desired thread profile is provided on its periphery and, after mounting, the spindle is tilted to contain the required helix angle. The work piece is revolved as usual and the shape of revolving grinding wheel is fed straight across the work axis. There is no need for longitudinal traverse of wheel spindle in this case, because the entire thread length is covered by the wheel face.

8. **Tool Post Grinder:** It consists of a bracket, which is mounted on the cross-slide, a grinding wheel and a separate motor. The grinding wheel is driven by a separate motor. The job is held in a chuck or between the centers and the rotating grinding wheel is fed against the job. The attachments may be for external or internal grinding. Some tool post grinders carry provisions such that the same attachments with a little change can be used for internal as well as external grinding.

UNIT-5**MODERN MACHINING PROCESS****INTRODUCTION**

Unconventional manufacturing processes is defined as a group of processes that remove excess material by various techniques involving mechanical, thermal, electrical or chemical energy or combinations of these energies but do not use a sharp cutting tools as it needs to be used for traditional manufacturing processes.

Extremely hard and brittle materials are difficult to machine by traditional machining processes such as turning, drilling, shaping and milling. Nontraditional machining processes, also called advanced manufacturing processes, are employed where traditional machining processes are not feasible, satisfactory or economical due to special reasons as outlined below.

Very hard fragile materials difficult to clamp for traditional machining

When the work piece is too flexible or slender

When the shape of the part is too complex

Manufacturing processes can be broadly divided into two groups)

- a) Primary manufacturing processes: Provide basic shape and size
- b) Secondary manufacturing processes: Provide final shape and size with tighter control on dimension, surface characteristics

Material Removal Processes Once Again Can Be Divided Into Two Groups

1. Conventional Machining Processes
2. Non-Traditional Manufacturing Processes or Unconventional Machining processes

Conventional Machining Processes mostly remove material in the form of chips by applying forces on the work material with a wedge shaped cutting tool that is harder than the work material under machining condition.

CHARACTERISTICS OF CONVENTIONAL MACHINING ARE:

- Generally macroscopic chip formation by shear deformation
- Material removal takes place due to application of cutting forces – energy domain can be Classified as mechanical
- Cutting tool is harder than work piece at room temperature as well as under machining Conditions

Non-conventional manufacturing processes is defined as a group of processes that remove excess material by various techniques involving mechanical, thermal, electrical or chemical energy or combinations of these energies but do not use a sharp cutting tools as it needs to be used for traditional manufacturing processes.

Material removal may occur with chip formation or even no chip formation may take place. For example in AJM, chips are of microscopic size and in case of Electrochemical machining material removal occurs due to electrochemical dissolution at atomic level.

NEED FOR UNCONVENTIONAL MACHINING PROCESSES

- Extremely hard and brittle materials or Difficult to machine material are difficult to Machine by traditional machining processes.
- When the work piece is too flexible or slender to support the cutting orgrinding Forces when the shape of the part is too complex.

CLASSIFICATION OF UCM PROCESSES:

1. Mechanical Processes

Abrasive Jet Machining (AJM)
Abrasive Water Jet Machining (AWJM)
Water Jet Machining (WJM)
Ultrasonic Machining (USM)

2. Electrochemical Processes

Electrochemical Machining (ECM)
Electro Chemical Grinding (ECG)
Electro Jet Drilling (EJD)

3. Electro-Thermal Processes

Electro-discharge machining (EDM)
Laser Jet Machining (LJM) Electron
Beam Machining (EBM)

4. Chemical Processes

Chemical Milling (CHM)
Photochemical Milling (PCM)

**BRIEF OVERVIEW****1. ULTRA SONIC MACHINING**

USM is a mechanical material removal process in which the material is removed by repetitive impact of abrasive particles carried in liquid medium on to the work surface, by a shaped tool, vibrating at ultrasonic frequency.

2. ABRASIVE JET MACHINING

It is the material removal process where the material is removed or machined by the impact erosion of the high velocity stream of air or gas and abrasive mixture, which is focused on to the work piece.

3. LASER BEAM MACHINING

Laser-beam machining is a thermal material-removal process that utilizes a high- Energy, Coherent light beam to melt and vaporize particles on the surface of metallic and non-Metallic work pieces. Lasers can be used to cut, drill, weld and mark. LBM is particularly suitable for making accurately placed holes

4. ELECTRON BEAM MACHINING

It is the thermo-electrical material removal process on which the material is removed by the high velocity electron beam emitted from the tungsten filament made to impinge on the work surface, where kinetic energy of the beam is transferred to the work piece material, producing intense heat, which makes the material to melt or vaporize it locally.

5. ELECTRO CHEMICAL MACHINING

It is the controlled removal of metals by the anodic dissolution in an electrolytic medium, where the work piece (anode) and the tool (cathode) are connected to the electrolytic circuit, which is kept, immersed in the electrolytic medium

6.ELECTRO CHEMICAL GRINDING

ECG is the material removal process in which the material is removed by the combination of Electro- Chemical decomposition as in ECM process and abrasive due to grinding.

7.PLASMA ARC MACHINING

Plasma is defined as the gas, which has been heated to a sufficiently high temperature to Become ionized.

8.WATER JET MACHINING

Water jet cutting can reduce the costs and speed up the processes by eliminating or reducing expensive secondary machining process. Since no heat is applied on the materials, cut edges are clean with minimal burr. Problems such as cracked edge defects, crystallization, hardening, reduced wealdability and machinability are reduced in this process.

9. ELECTRICAL DISCHARGE MACHINING

EDM is the controlled erosion of electrically conductive materials by the Initiation of rapid and repetitive spark discharge between the electrode tool to the cathode and work to anode separated by a small gap kept in the path of dielectric medium. This Process also called spark erosion.



Comparison between conventional machining and non conventional machining process.

Conventional machining process	Non conventional machining process
1. Direct contact between tool and work piece.	1. Tools are non-conventional technique like Laser beam, electric arc etc.
2. Cutting tool is harder than work piece.	2. Tool may not be harder and it may not be physical presence.
3. Tool life is less due to high wear.	3. Tool life is more.
4. Generally Macroscopic chip formation.	4. Material removal occurs with or without chip formation.
5. Material removal takes place due to application of cutting force.	5. It uses different energy like electrical, Thermo-Chemical etc. to provide machining.
6. Suitable for all material.	6. Not suitable for all material.
7. It cannot be used to make prototype parts very effectively.	7. It can be used to produce prototype parts very effectively.

1. EDM (ELECTRO DISCHARGE MACHINING PROCESS)

Electrical discharge machining (EDM) is one of the most widely used non-traditional machining processes. The main attraction of EDM over traditional machining processes such as metal cutting using different tools and grinding is that this technique utilizes thermoelectric process to erode undesired materials from the work piece by a series of discrete electrical sparks between the work piece and the electrode. A picture of EDM machine in operation

The traditional machining processes rely on harder tool or abrasive material to remove the softer material whereas non-traditional machining processes such as EDM uses electrical spark or thermal energy to erode unwanted material in order to create desired shape. So, the hardness of the material is no longer a dominating factor for EDM process. A schematic of an EDM process is shown in Figure where the tool and the work piece are Immersed in a dielectric fluid.

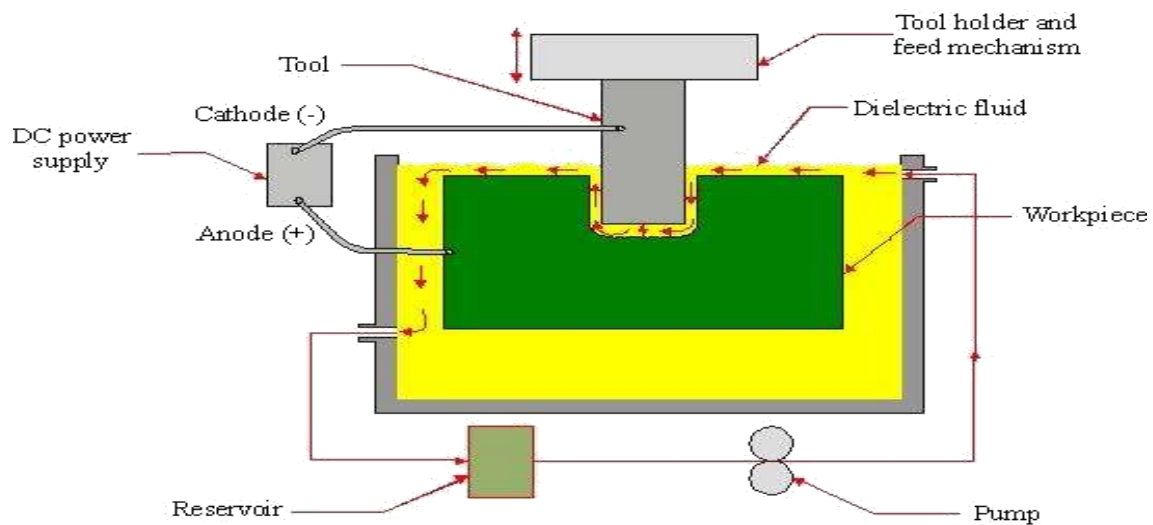

EDM removes material by discharging an electrical current, normally stored in a capacitor bank, across a small gap between the tool (cathode) and the work piece (anode) typically in order

Application of EDM

The EDM process has the ability to machine hard, difficult-to-machine materials. Parts with complex, precise and irregular shapes for forging, press tools, extrusion dies, difficult internal shapes for aerospace and medical applications can be made by EDM process. Some of the shapes made by EDM process are shown in Figure.



Figure: Difficult internal parts made by EDM process

Working principle of EDM

As shown in Figure at the beginning of EDM operation, a high voltage is applied across the narrow gap between the electrode and the work piece. This high voltage induces an electric field in the insulating dielectric that is present in narrow gap between electrode and workpiece. This cause conducting particles suspended in the dielectric to concentrate at the points of strongest electrical field. When the potential difference between the electrode and the workpiece is sufficiently high, the dielectric breaks down and a transient spark discharges through the dielectric fluid, removing small amount of material from the workpiece surface. The volume of the material removed per spark discharge is typically in the range of 10⁻⁶ to 10⁻⁶ mm³.

The material removal rate, MRR, in EDM is calculated by the

following formula: $MRR = 40 I / T_m^{1.23}$ (cm³/min)

Where, I is the current amp, T_m is the melting temperature of workpiece in °C

Advantages of EDM

- By this process, materials of any hardness can be machined;
- No burrs are left in machined surface;
- One of the main advantages of this process is that thin and fragile/brittle components can be machined without distortion;
- Complex internal shapes can be machined

Limitations of EDM

- This process can only be employed in electrically conductive materials;
- Material removal rate is low and the process overall is slow compared to conventional machining processes;
- Unwanted erosion and over cutting of material can occur;
- Rough surface finish when at high rates of material removal.

Dielectric fluids:

Dielectric fluids used in EDM process are hydrocarbon oils, kerosene and deionised water. The functions of the dielectric fluid are to:

- Act as an insulator between the tool and the workpiece.
- Act as coolant.
- Act as a flushing medium for the removal of the chips.

The electrodes for EDM process usually are made of graphite, brass, copper and copper-tungsten alloys.

Design considerations for EDM process are as follows:

Deep slots and narrow openings should be avoided.

- The surface smoothness value should not be specified too fine.
- Rough cut should be done by other machining process. Only finishing operation should be done in this process as MRR for this process is low.

WIRE CUT ELECTRICAL DISCHARGE MACHINING (WCEDM)

EDM, primarily, exists commercially in the form of die-sinking machines and wire- process, a slowly moving wire travels along a prescribed path and removes material from the workpiece. Wire EDM uses electro-thermal mechanisms to cut electrically conductive materials. The material is removed by a series of discrete discharges between the wire electrode and the workpiece in the presence of dielectric fluid, which creates a path for each discharge as the fluid becomes ionized in the gap. The area where discharge takes place is heated to extremely high temperature, so that the surface is melted and removed. The removed particles are flushed away by the flowing dielectric fluids.

The wire EDM process can cut intricate components for the electric and aerospace industries. This non-traditional machining process is widely used to pattern tool steel for die manufacturing cutting machines (Wire EDM). The concept of wire EDM is shown in Figure . In this



Figure: Wire erosion of an extrusion die

The wires for wire EDM is made of brass, copper, tungsten, molybdenum. Zinc or brass coated wires are also used extensively in this process. The wire used in this process should posse's high tensile strength and good electrical conductivity. Wire EDM can also employ to cut cylindrical objects with high precision. The sparked



eroded extrusion dies are presented in Figure.

This process is usually used in conjunction with CNC and will only work when a part is to be cut completely through. The melting temperature of the parts to be machined is an important parameter for this process rather than strength or hardness. The surface quality and MRR of the machined surface by wire EDM will depend on different machining parameters such as applied peak current, and wire materials.

The wires for wire EDM is made of brass, copper, tungsten, molybdenum. Zinc or brass coated wires are also used extensively in this process. The wire used in this process should possess high tensile strength and good electrical conductivity. Wire EDM can also employ to cut cylindrical objects with high precision. The sparked eroded extrusion



dies are presented in Figure 5.

Figure: Sparked eroded extrusion dies

This process is usually used in conjunction with CNC and will only work when a part is to be cut completely through. The melting temperature of the parts to be machined is an important parameter for this process rather than strength or hardness. The surface quality and MRR of the machined surface by wire EDM will depend on different machining parameters such as applied peak current, and wire materials.

ABRASIVE JET MACHINING (AJM)

In Abrasive Jet Machining (AJM), abrasive particles are made to impinge on the work material at a high velocity. The high velocity abrasive particles remove the material by micro-cutting action as well as brittle fracture of the work material.

In AJM, generally, the abrasive particles of around 50 μm grit size would impinge on the work material at velocity of 200 m/s from a nozzle of I.D. of 0.5 mm with a standoff distance of around 2 mm. The kinetic energy of the abrasive particles would be sufficient to provide material removal due to brittle fracture of the work piece or even micro cutting by the abrasives.

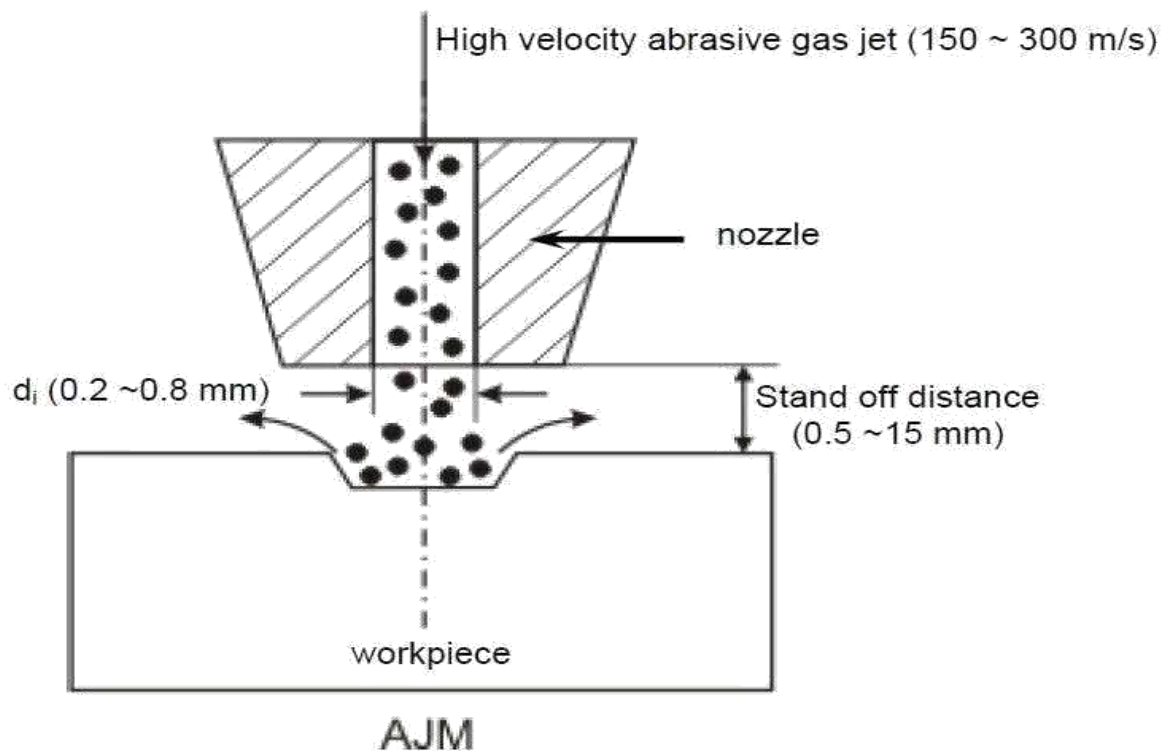

Schematic Arrangement Of Ajm

Process Parameters and Machining Characteristics

Abrasive: Material – Al_2O_3 / SiC
 / glass beads Shape – irregular /
 spherical

Size – $10 \sim 50 \mu m$

Mass flow rate – $2 \sim 20 \text{ gm/min}$

Carrier gas: Composition – Air,
 CO_2 , N_2 Density – Air ~ 1.3
 kg/m^3

Velocity – $500 \sim 700 \text{ m/s}$ Pressure

– $2 \sim 10 \text{ bar}$ Flow rate – $5 \sim 30$

lpm

Abrasive Jet : Velocity – $100 \sim 300 \text{ m/s}$

Mixing ratio – mass flow ratio of
 abrasive to gas Stand-off distance – $0.5 \sim$
 5 mm

Impingement Angle

– $60 \sim 90$ Nozzle:

Material – WC

Diameter – (Internal) 0.2

$\sim 0.8 \text{ mm}$ Life – $10 \sim 300$

hours

Modeling of material removal

Material removal in AJM takes place due to brittle fracture of the work material due to impact of high velocity abrasive particles.

Modeling has been done with the following assumptions:

- (i) Abrasives are spherical in shape and rigid. The particles are characterized by the mean grit diameter
- (ii) The kinetic energy of the abrasives are fully utilized in removing material
- (iii) Brittle materials are considered to fail due to brittle fracture and the fracture volume is considered to be hemispherical with diameter equal to chordal length of the indentation
- (iv) For ductile material, removal volume is assumed to be equal to the indentation volume due to particulate impact

WATER JET MACHINING (WJM)

Introduction

Water jet cutting can reduce the costs and speed up the processes by eliminating or reducing expensive secondary machining process. Since no heat is applied on the materials, cut edges are clean with minimal burr. Problems such as cracked edge defects, crystallization, hardening, reduced weld ability and machinability are reduced in this process.

Water jet technology uses the principle of pressurizing water to extremely high pressures, and allowing the water to escape through a very small opening called “orifice” or “jewel”. Water jet cutting uses the beam of water exiting the orifice to cut soft materials. This method is not suitable for cutting hard materials. The inlet water is typically pressurized between 1300 – 4000 bars. This high pressure is forced through a tiny hole in the jewel, which is typically 0.18 to

0.4 mm in diameter. Picture of water jet machining process.

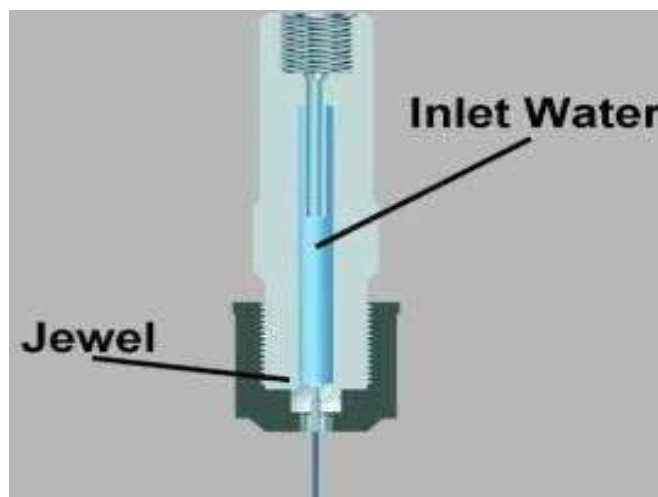

Applications.

Water jet cutting is mostly used to cut lower strength materials such as wood, plastics and aluminum. When abrasives are added, (abrasive water jet cutting) stronger materials such as steel and tool steel.

Advantages Of Water Jet Cutting

1. There is no heat generated in water jet cutting; which is especially useful for cutting tool steel and other metals where excessive heat may change the properties of the material.
2. Unlike machining or grinding, water jet cutting does not produce any dust or particles that are harmful if inhaled.

3. Other advantages are similar to abrasive water jet cutting

Disadvantages of water jet cutting

1. One of the main disadvantages of water jet cutting is that a limited number of materials can be cut economically.
2. Thick parts cannot be cut by this process economically and accurately
3. Taper is also a problem with water jet cutting in very thick materials. Taper is when the jet exits the part at different angle than it enters the part, and cause dimensional inaccuracy.

ABRASIVE WATER-JET MACHINING (AWJM)

Introduction

Abrasive water jet cutting is an extended version of water jet cutting; in which the water jet contains abrasive particles such as silicon carbide or aluminium oxide in order to increase the material removal rate above that of water jet machining. Almost any type of material ranging from hard brittle materials such as ceramics, metals and glass to extremely soft materials such as foam and rubbers can be cut by abrasive water jet cutting. The narrow cutting stream and computer controlled movement enables this process to produce parts accurately and efficiently. This machining process is especially ideal for cutting materials that cannot be cut by laser or thermal cut. Metallic, non-metallic and advanced composite materials of various thicknesses can be cut by this process. This process is particularly suitable for heat sensitive materials that cannot be machined by processes that produce heat while machining.

The schematic of abrasive water jet cutting is shown in Figure 15 which is similar to water jet cutting apart from some more features underneath the jewel; namely abrasive, guard and mixing tube. In this process, high velocity water exiting the jewel creates a vacuum which sucks abrasive from the abrasive line, which mixes with the water in the mixing tube to form a high velocity beam of abrasives.

Applications

Abrasive water jet cutting is highly used in aerospace, automotive and electronics industries. In aerospace industries, parts such as titanium bodies for military aircrafts, engine components (aluminum, titanium, and heat resistant alloys), aluminum body parts and interior

cabin parts are made using abrasive water jet cutting. In automotive industries, parts like interior trim (head liners, trunk liners, and door panels) and fiber glass body components and bumpers are made by this process. Similarly, in electronics industries, circuit boards and cable stripping are made by abrasive water jet cutting.

Advantages of abrasive water jet cutting

- In most of the cases, no secondary finishing required
- No cutter induced distortion
- Low cutting forces on work pieces
- Limited tooling requirements
- Little to no cutting burr
- Typical finish 125-250 microns
- Smaller kerf size reduces material wastages
- No heat affected zone
- Localises structural changes
- No cutter induced metal contamination
- Eliminates thermal distortion
- No slag or cutting dross
- Precise, multi plane cutting of contours, shapes, and bevels of any angle.

Limitations of abrasive water jet cutting

- Cannot drill flat bottom
- Cannot cut materials that degrades quickly with moisture

Surface finish degrades at higher cut speeds which are frequently used

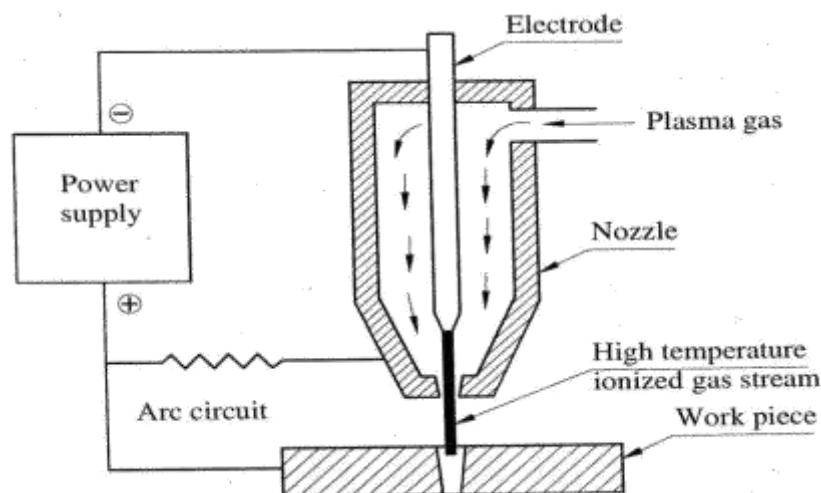
**PLASMA ARC MACHINING**

The plasma welding process was introduced to the welding industry in 1964 as a method of bringing better control to the arc welding process in lower current ranges. Today, plasma retains the original advantages it brought to industry by providing an advanced level of control and accuracy to produce high quality welds in miniature or precision applications and to provide long electrode life for high production requirements

Principles of Operation: The plasma arc welding process is normally compared to the gas tungsten arc process. But in the TIG-process, the arc is burning free and unhandled, whereas in the plasma-arc system, the arc is necked by an additional water-cooled plasma-nozzle. A plasma gas – almost always 100 % argon – flows between the tungsten electrode and the plasma nozzle. The welding process involves heating a gas called plasma to an extremely high temperature and then ionizing it such that it becomes electrically conductive. The plasma is used to transfer an electric arc called pilot arc to a work piece which burns between the tungsten electrode and the plasma nozzle. By forcing the plasma gas and arc through a constricted orifice the metal, which is to be welded is melted by the extreme heat of the arc. The weld pool is protected by the shielding gas, flowing between the outer shielding gas nozzle and the plasma nozzle. As shielding gas pure argon-rich gas-mixtures with hydrogen or helium are used.

The high temperature of the plasma or constricted arc and the high velocity plasma jet provide an increased heat transfer rate over gas tungsten arc welding when using the same current. This results in faster welding speeds and deeper weld penetration. This method of operation is used for welding extremely thin material and for welding multi pass groove and welds and fillet welds.

Uses & Applications:

Plasma arc welding machine is used for several purposes and in various fields. The common application areas of the machine are:

1. Single runs autogenous and multi-run circumferential pipe welding.
2. In tube mill applications.
3. Welding cryogenic, aerospace and high temperature corrosion resistant alloys.
4. Nuclear submarine pipe system (non-nuclear sections, sub assemblies).
5. Welding steel rocket motor cases.
6. Welding of stainless steel tubes (thickness 2.6 to 6.3 mm).
7. Welding of carbon steel, stainless steel, nickel, copper, brass, monel.

ULTRASONIC MACHINING (USM)

USM is mechanical material removal process or an abrasive process used to erode holes or cavities on hard or brittle work piece by using shaped tools, high frequency mechanical motion and an abrasive slurry. USM offers a solution to the expanding need for machining brittle materials such as single crystals, glasses and polycrystalline ceramics, and increasing complex operations to provide intricate shapes and work piece profiles. It is therefore used extensively in machining hard and brittle materials that are difficult to machine by traditional manufacturing processes. The hard particles in slurry are accelerated toward the surface of the work piece by a tool oscillating at a frequency up to 100 KHz - through repeated abrasions, the tool machines a cavity of a cross section identical to its own.

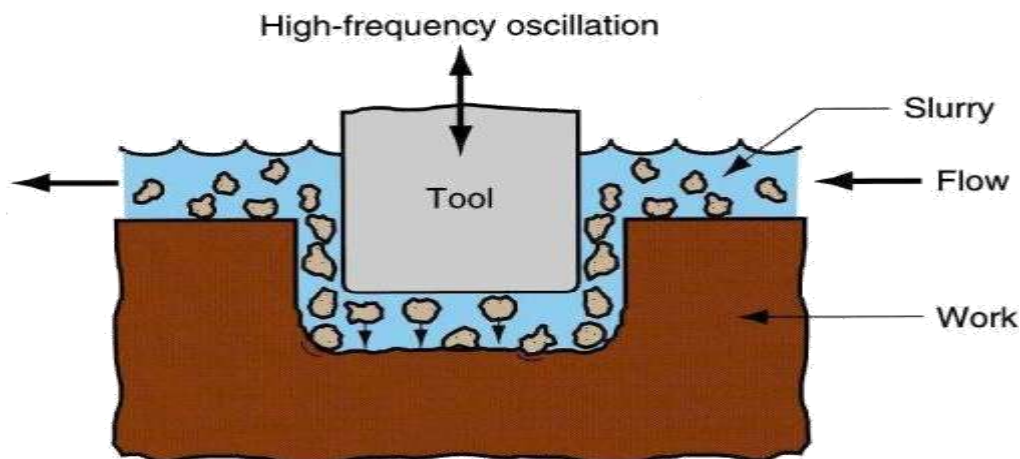

USM is primarily targeted for the machining of hard and brittle materials (dielectric or conductive) such as boron carbide, ceramics, titanium carbides, rubies, quartz etc. USM is a versatile machining process as far as properties of materials are concerned. This process is able to effectively machine all materials whether they are electrically conductive or insulator.

For an effective cutting operation, the following parameters need to be carefully considered

The machining tool must be selected to be highly wear resistant, such as high-carbon steels. The abrasives (25-60 μm in dia.) in the (water-based, up to 40% solid volume) slurry Includes: Boron carbide, silicon carbide and aluminum oxide.

Applications

The beauty of USM is that it can make non round shapes in hard and brittle materials. Ultrasonically machined non round-hole part is shown in Figure

Advantage of USM

1. USM process is a non-thermal, non-chemical, creates no changes in the microstructures, chemical or physical properties of the work piece and offers virtually stress free machined surfaces.
2. Any materials can be machined regardless of their electrical conductivity Especially suitable for machining of brittle materials

3. Machined parts by USM possess better surface finish and higher structural integrity. USM does not produce thermal, electrical and chemical abnormal surface

Disadvantages of USM

- USM has higher power consumption and lower material-removal rates than traditional Fabrication processes.
- Tool wears fast in USM.
- Machining area and depth is restraint in USM.

ABRASIVE JET MACHINING

Abrasive jet machining is mechanical energy based unconventional machining process used to remove unwanted material from a given work piece.

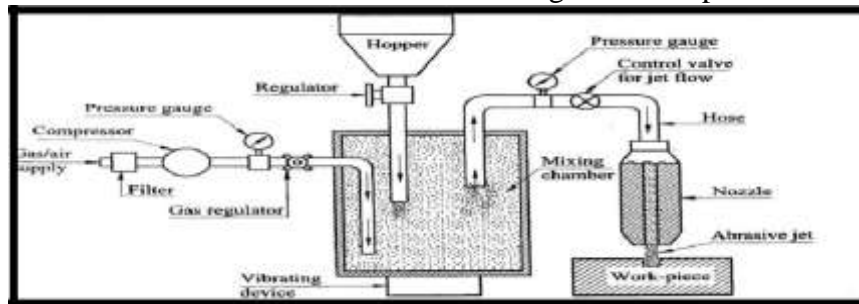

CONSTRUCTION It consist of Compressor (To pressurize the gas), Filter, mixing chamber, Hopper, Vibrator, Nozzle, Pressure gauge and flow regulator.

The nozzle is made of a hard material like tungsten carbide.

Abrasive used are aluminum oxide, Silicon carbide, or Sodium bicarbonate.

The gases commonly used are air, N₂, CO₂.

Hopper is placed above mixing chamber for feeding purpose.

Vibrating device placed below mixing chamber to vibrate mixture of abrasive and gas.

WORKING

First dry air or gas is filtered and then it compressed by compressor.

A pressure gauge and flow regulator control the pressure and regulate the flow of the compressed air. Compressed air entered into the mixing chamber where it mixed with abrasive particles.

Then mixture passes through nozzle where high velocity fine abrasive jet is produced. The nozzle increases velocity about 200 to 400 m/s at the expense of it's pressure.

APPLICATIONS:

Drilling, Cleaning, and polishing of hard surface.

To machine intricate shapes which is difficult to machine.

Aircraft fuel system, Medical appliances and Hydraulic valves.

Advantage of Abrasive Jet Machining:

No heat is generated in work. So it is suitable for heat sensitive materials.

No physical contact between tool and work.

Thin and fragile materials also machined.

Low investment.

Smooth surface finish.

Disadvantage:

Low MRR.

Abrasive powder cannot be reused.

Nozzle life is less and maintenance of nozzle required.

Factors affecting performance of AJM:

Abrasive grain size and It's mass flow rate

Mixing ratio.

Velocity of abrasive particles.

Gas pressure.

Nozzle tip distance.

QUESTION BANK**UNIT-1**

1. Different various tool angles used in single point cutting tools with a neat sketch?
2. Explain ASA and ORS system tool nomenclature?
3. What are the requirements of cutting tool materials?
4. Explain the mechanism of chip formation in metal cutting with a neat sketch?
5. Explain the types of chips with neat sketches?
6. What is built up edge and what are its effects state the causes and remedies?
7. Explain with neat sketch types of chip breakers?
8. Explain the use of Merchant's circle diagram? explain the diagram indicating cutting forces?
9. Explain the methods for changing feed in gear boxes of machine tool?
10. Explain the terms of machinability and tool life?

UNIT-2

1. Explain with a neat sketch working of a lathe machine?
2. What are the difference between capstan and turret lathe?
3. classify the different types of lathe giving brief use of each one?
4. What are various work holding devices in a lathe & explain with a neat sketches?
5. a. What are various types of taper turning methods with a neat sketches?
b. Why cast iron used for lathe beds? explain?
6. Explain tool holding devices with a neat sketches?
7. What are the elements and benefits CNC system?
8. How CNC machine works and give advantages and limitations?
9. Explain the main parts of CNC machine and applications?
10. Explain in detail of CNC machine with neat block diagram?

UNIT-3

1. Explain the principle of shaping mechanism with a neat sketch?
2. Differentiate among shaping, planing and slotting machines with regard to construction and working?
3. Explain the various types of hole making operations that can be performed in drilling machine?
4. with the help of line diagram, explain the basic principle, construction details and working of a shaper?
5. Explain clearly what is mean by jig boring with a neat sketch??

6. Write a short notes on horizontal boring machine, mention the applications?
7. Explain about drilling and boring operations? And explain deep hole drilling machine with a neat sketch?
8. Explain twist drill with a neat sketch and its advantages?
9. What are the types of drilling machines explain any two types with a neat sketches?
10. What are the tool holding devices in boring and drilling?

UNIT-4

1. Explain the construction of plain milling machine with a neat sketch?
2. State various types of milling cutters explain any three of them with neat sketches?
3. Describe the working features of a universal milling machine with the help of a neat sketch?
4. Explain about up milling and down milling with a neat sketches?
5. Explain the different types of bonds used in manufacturing of grinding wheel?
6. Explain with a neat sketch and construction of tool and cutter grinding machine?
7. Explain and construction of surface grinding with a neat sketch?
8. Explain the construction of centreless grinding machine with a neat sketch & advantages ?
9. Types of grinding machines and explain any of two with a neat sketches?
10. a) With simple sketches i) Traverse cylindrical grinding ii) Plunge centre type iii) Profile cylindrical grinding
b) Explain the terms speed, feed and depth of cut as applicable to grinding work

UNIT-5

1. What is the difference between traditional and non-traditional machining process?
2. Explain the principle of abrasive water jet machining with neat sketch?
- 3a). what are the advantages and disadvantages of AJM and WJM?
b) Explain the principle of ultrasonic machining process with a neat sketch?
4. What are the process variables of modern machining process?
5. What are the dielectric fluids and selection of tools required for modern machining process?
6. Explain the principle of ECM, EDM with neat sketches?
7. Explain power circuits used in EDM process?
8. a) With the help of neat diagram explain the construction of Plasma arc machining system?
b) What are the different modes of plasma torches ? Explain?
9. What are the applications & advantages of PAM (Plasma arc machining)?
10. What are the recent development of modern machining process?